



K.S INSTITUTE OF TECHNOLOGY

#14, Raghuvanahalli, Kanakapura Main Road, Bengaluru - 560109

Phone: 080-28435722/24 website: www.ksit.ac.in

** DEPARTMENT OF TRAINING AND PLACEMENTS **

16.01.2023

PERSONALITY DEVELOPMENT TRAINING PROGRAM FOR FIRST SEMESTER STUDENTS

Placement department has planned to conduct **Personality Development Training Program for 1st Semester students (All branches)** from 23rd to 27th January 2023. All HOD's are hereby informed to communicate their first year students regarding the same.

The training will be conducted in **new building classrooms**. Batch wise details are shared below. All **placement coordinators/Class teachers** are **requested** to submit the consolidated attendance of all 4 days to placement department on or before **30th January 2023** without fail.

Department wise scheduled is given below for your reference.

| Date | Time | B1 | B2 | B3 | B4 | B5 | B6 | B7 | B8 | B9 |
|--|-------------------|-------------|-------|-------|-----|------|-------|-------|-----|----------|
| | | CSE A | CSE B | CSE C | CSD | AIML | ECE A | ECE B | IoT | CCE + ME |
| 23 rd , 24 th , 25 th & 27 th January 2023 | 8:55 AM – 11:00AM | 101 | 102 | 104 | 202 | 203 | 205 | 301 | 302 | 304 |
| | 11:00AM – 11:15AM | BREAK | | | | | | | | |
| | 11:15 AM – 1:15PM | 101 | 102 | 104 | 202 | 203 | 205 | 301 | 302 | 304 |
| | 1:15PM – 1:50PM | LUNCH BREAK | | | | | | | | |
| | 1.50PM – 4:00PM | 101 | 102 | 104 | 202 | 203 | 205 | 301 | 302 | 304 |

NOTE:

1. All students are informed to attend the training compulsory.
2. Minimum attendance should be 90% failing which, students are not allowed for campus drives.
3. Students are strictly informed to be present in their allocated rooms for all days.

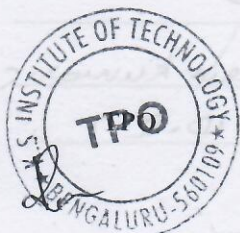

Class Teacher
Placement Coordinator
 Mr. Krishna Gudi
 Mr. T. Somashekar
 are requested
 to coordinate
 R

K. Kumar .G.

PRINCIPAL
 PRINCIPAL
 K.S. INSTITUTE OF TECHNOLOGY
 BENGALURU - 560 109.

CC TO:

HODs and Coordinators/Class teachers of:

| | | | | | | | |
|--------|-----|-----|------|-----|-----|-----|----|
| BS & H | CSE | ECE | AIML | CSD | IoT | CCE | ME |
|--------|-----|-----|------|-----|-----|-----|----|

**Fwd: TRAINING REPORT-2022-2023**

1 message

SOMASEKHAR T <somasekhart@ksit.edu.in>
To: divyarg@ksit.edu.in

Wed, May 24, 2023 at

----- Forwarded message -----

From: KSIT PLACEMENTCELL <placementcell@ksit.edu.in>

Date: Thu, May 18, 2023 at 9:36 AM

Subject: TRAINING REPORT-2022-2023

To: <somasekhart@ksit.edu.in>

**PERSONALITY DEVELOPMENT TRAINING PROGRAM LIFE SKILLS @ KSIT
ORGANISED BY PLACEMENT DIVISON
ACADEMIC YEAR (2021-2022)-(2022-2023)**

TRAINING DETAILS:01-05-22 TO 31-03-23

| S.No | Name of Event | Year | Sem | Vendor | Venue | Training Programe Schedule | | Branch |
|------|------------------------------------|------|-----|---------------------|--------------|----------------------------|------------|--------|
| | | | | | | From | To | |
| 1 | PERSONALITY DEVELOPMENT PROGRAM | 2022 | 2nd | THE SKILL FACTORY | SEMINAR HALL | 27/06/2022 | 01/07/2022 | All |
| 2 | PERSONALITY DEVELOPMENT PROGRAM | 2022 | 4th | JV GLOBAL | SEMINAR HALL | 27/06/2022 | 01/07/2022 | All |
| 3 | PERSONALITY DEVELOPMENT PROGRAM | 2022 | 6th | BIZOTIC | SEMINAR HALL | 27/06/2022 | 01/07/2022 | All |
| 4 | INTERNSHIP TRAINING PROGRAM | 2022 | 3th | AUDAZ VENTURES | CLASS ROOMS | 11/10/2022 | 15/11/2022 | All |
| 5 | NTT DATA-SPECIFIC TRAINING PROGRAM | 2022 | 7th | BIZOTIC | CLASS ROOMS | 26/09/2022 | 28/09/2022 | All |
| 6 | PERSONALITY DEVELOPMENT PROGRAM | 2022 | 7th | UNIVERSAL EDUCATION | CLASS ROOMS | 02/11/2022 | 08/11/2022 | All |
| 7 | PERSONALITY DEVELOPMENT PROGRAM | 2022 | 2nd | THE SKILL FACTORY | CLASS ROOMS | 27/06/2022 | 01/07/2022 | All |
| 8 | PERSONALITY DEVELOPMENT PROGRAM | 2022 | 6th | BIZOTIC | CLASS ROOMS | 27/06/2022 | 01/07/2022 | All |
| 9 | PERSONALITY DEVELOPMENT PROGRAM | 2022 | 4th | J V GLOBAL SERVICES | CLASS ROOMS | 27/06/2022 | 01/07/2022 | All |
| 10 | PERSONALITY DEVELOPMENT PROGRAM | 2023 | 1st | TRANSIT | CLASS ROOMS | 23/01/2023 | 27/01/2023 | All |

--
Thanks and Regards,

Mrs. Preethi
Placement Executive,
Department of Training & Placement,
K S Institute of Technology,
No.14, Raghuvanahalli,
Kanakapura Main Road,
Bengaluru-560109, Karnataka, India.
Mob: +91 91487 12971

| | Batch 01 | Batch 02 | Batch 03 | Batch 04 | Batch 05 | Batch 06 | Batch 07 | Batch 08 | Batch 09 |
|-----|------------------------|------------------------|------------------------|------------------------|------------------------|------------------------|------------------------|------------------------|------------------------|
| | CS A | CS B | CS C | CSD | AIML | EC A | EC B | IOT | CCE+ME |
| | 101 | 102 | 104 | 202 | 203 | 205 | 301 | 302 | 304 |
| S1 | Sam | Vedavathi | Shiva | Jhanavi | Ashfak | Arun Sax | Srinath | Imran | Panchami |
| | Work Culture | Adaptability | Stress Management | Conflict Resolution | Letter Email LinkedIn | Problem Solving | SWOT Analysis | Confidence Building | Active Listening |
| S2 | Panchami | Sam | Vedavathi | Shiva | Jhanavi | Ashfak | Arun Sax | Srinath | Imran |
| | Active Listening | Work Culture | Adaptability | Stress Management | Conflict resolution | Letter Email LinkedIn | Problem Solving | SWOT Analysis | Confidence Building |
| S3 | Imran | Panchami | Sam | Vedavathi | Shiva | Jhanavi | Ashfak | Arun Sax | Srinath |
| | Confidence Building | Active Listening | Work Culture | Adaptability | Stress Management | Conflict resolution | Letter Email LinkedIn | Problem Solving | SWOT Analysis |
| S4 | Srinath | Imran | Panchami | Sam | Vedavathi | Shiva | Jhanavi | Ashfak | Arun Sax |
| | SWOT Analysis | Confidence building | Active Listening | Work Culture | Adaptability | Stress Management | Conflict resolution | Letter Email LinkedIn | Problem Solving |
| S5 | Arun Sax | Srinath | Imran | Panchami | Sam | Vedavathi | Shiva | Jhanavi | Ashfak |
| | Problem solving | SWOT Analysis | Confidence building | Active Listening | Work Culture | Adaptability | Stress Management | Conflict resolution | Letter Email LinkedIn |
| S6 | Ashfak | Arun Sax | Srinath | Imran | Panchami | Sam | Vedavathi | Shiva | Jhanavi |
| | Letter Email LinkedIn | Problem Solving | SWOT Analysis | Confidence Building | Active Listening | Work Culture | Adaptability | Stress Management | Conflict resolution |
| S7 | Jhanavi | Prem | Arun Sax | Srinath | Imran | Panchami | Ajay | Vedavathi | Shiva |
| | Conflict resolution | Professionalism | Problem Solving | SWOT Analysis | Confidence building | Active Listening | Intrapersonal skills | Adaptability | Stress Management |
| S8 | Shiva | Jhanavi | Prem | Arun Sax | Srinath | Imran | Panchami | Ajay | Vedavathi |
| | Stress Management | Conflict resolution | Professionalism | Problem Solving | SWOT Analysis | Confidence building | Active Listening | Intrapersonal skills | Adaptability |
| S9 | Vedavathi | Shiva | Jhanavi | Prem | Arun Sax | Srinath | Imran | Panchami | Ajay |
| | Adaptability | Stress Management | Conflict resolution | Professionalism | Problem Solving | SWOT Analysis | Confidence building | Active Listening | Intrapersonal skills |
| S10 | Ajay | Ashfak | Shiva | Jhanavi | Prem | Arun Sax | Srinath | Imran | Panchami |
| | Intrapersonal skills | Letter Email LinkedIn | Communication skills 2 | Grooming | Professionalism | Decision Making | Emotional Intelligence | Grooming | Communication skills 2 |
| S11 | Panchami | Ajay | Ashfak | Shiva | Jhanavi | Prem | Arun Sax | Srinath | Imran |
| | Communication skills 2 | Intrapersonal skills | Letter Email LinkedIn | Communication skills 2 | Grooming | Professionalism | Decision Making | Emotional Intelligence | Grooming |
| S12 | Imran | Panchami | Ajay | Ashfak | Shiva | Jhanavi | Prem | Arun Sax | Srinath |
| | Grooming | Communication skills 2 | Intrapersonal skills | Letter Email LinkedIn | Communication skills 2 | Grooming | Professionalism | Decision Making | Emotional Intelligence |
| S13 | Srinath | Imran | Panchami | Ajay | Vedavathi | Shiva | Sam | Prem | Arun Sax |
| | Emotional Intelligence | Grooming | Decision Making | Intrapersonal skills | Emotional Intelligence | Communication skills 2 | Work Culture | Professionalism | Decision Making |
| S14 | Arun Sax | Jhanavi | Imran | Panchami | Ajay | Vedavathi | Shiva | Sam | Prem |
| | Decision Making | Emotional Intelligence | Grooming | Decision Making | Intrapersonal skills | Emotional Intelligence | Communication skills 2 | Work Culture | Professionalism |
| S15 | Prem | Arun Sax | Srinath | Imran | Panchami | Ajay | Jhanavi | Shiva | Sam |
| | Professionalism | Decision Making | Emotional Intelligence | Emotional Intelligence | Decision Making | Intrapersonal skills | Emotional Intelligence | Communication skills 2 | Work Culture |

K.S.INSTITUTE OF TECHNOLOGY

2nd SEM SOFTSKILL TRAINING

DEPARTMENT OF PLACEMENT & PLACEMENTS

CSE- A- SECTION

| SL.NO | USN | NAME OF THE STUDENT |
|-------|------------|------------------------------|
| 1 | 1KS21CS013 | ANUBHAV MISRA (RE-ADMISSION) |
| 2 | 1KS22CS001 | ABENI B |
| 3 | 1KS22CS002 | ABHISHEK A |
| 4 | 1KS22CS003 | ACHYUTHA U N |
| 5 | 1KS22CS004 | ADITHYA M |
| 6 | 1KS22CS005 | ADITYA S |
| 7 | 1KS22CS006 | ADITYA VENKATESH |
| 8 | 1KS22CS007 | AKASH JADHAV |
| 9 | 1KS22CS008 | AKASH S R |
| 10 | 1KS22CS009 | AKSHAY KRISHNA K S |
| 11 | 1KS22CS010 | AMRUTHA N |
| 12 | 1KS22CS011 | ANANYA C |
| 13 | 1KS22CS012 | ANANYA S |
| 14 | 1KS22CS013 | ANIRUDH ADONI |
| 15 | 1KS22CS014 | ANIRUDH SURESH |
| 16 | 1KS22CS015 | ANIRUDH M MUDAMBI |
| 17 | 1KS22CS016 | ANKITA N |
| 18 | 1KS22CS017 | ANMOL NAIK S |
| 19 | 1KS22CS018 | ANUKA KIRANA KUMAR |
| 20 | 1KS22CS019 | ANUSHKA SHRIPAD GULAVANI |

546

| | | |
|----|------------|-------------------------------|
| 46 | IKS22CS045 | GNANESH S |
| 47 | IKS22CS046 | GUNITH RAVIKIRAN |
| 48 | IKS22CS047 | GURURAJ V A |
| 49 | IKS22CS048 | HARCHITHA M |
| 50 | IKS22CS049 | HARSHADITHYA G V |
| 51 | IKS22CS050 | HEMAMBHIKA B N |
| 52 | IKS22CS051 | HIMASHWETHA K G |
| 53 | IKS22CS052 | ISHA MAJI |
| 54 | IKS22CS053 | JAHNAVI J H |
| 55 | IKS22CS054 | JAYASHREE KUMAR CHIGARI |
| 56 | IKS22CS055 | JYOTHSNA R |
| 57 | IKS22CS056 | K M THEJDEEP KRISHNA |
| 58 | IKS22CS057 | KAMNOOR ADITYA |
| 59 | IKS22CS058 | KARABASAVVA SUBHASA DODDAMANI |
| 60 | IKS22CS059 | KARTHIK KUMAR R |
| 61 | IKS22CS060 | KARTHIK V |
| 62 | IKS22CS061 | KAVITA REVANAPPA TAMBAGI |
| 63 | IKS22CS062 | KIRAN C P |

K.S.INSTITUTE OF TECHNOLOGY**2nd SEM SOFTSKILL TRAINING****DEPARTMENT OF PLACEMENT & PLACEMENTS****CSE- B SECTION**

| SL NO | USN | NAME |
|--------------|------------|-----------------------|
| 1 | 1KS22CS063 | KRUTHANVA R |
| 2 | 1KS22CS064 | KUSHI M |
| 3 | 1KS22CS065 | L DEEKSHA |
| 4 | 1KS22CS066 | L SHREYAS SRINIVAS |
| 5 | 1KS22CS067 | LAKSHMI SHREE K P |
| 6 | 1KS22CS068 | LALITHYA S |
| 7 | 1KS22CS069 | LEKHANA L |
| 8 | 1KS22CS070 | LIKHITH K |
| 9 | 1KS22CS071 | LIPIKA J |
| 10 | 1KS22CS072 | M ASHRITHA |
| 11 | 1KS22CS073 | M N AMOGH ATHREYA |
| 12 | 1KS22CS074 | MADDURI YAVANIKA |
| 13 | 1KS22CS075 | MALLIKARJUN K S |
| 14 | 1KS22CS076 | MANASVI H Y |
| 15 | 1KS22CS077 | MANOJA G V |
| 16 | 1KS22CS078 | MEGHA S |
| 17 | 1KS22CS079 | MINAKSHI ANIL BADIFER |
| 18 | 1KS22CS080 | MISBA SABA |
| 19 | 1KS22CS081 | MOHAMMED TAHIR |
| 20 | 1KS22CS082 | MOHAMMED YAHYA NAZIM |
| 21 | 1KS22CS083 | MOKESH G R |
| 22 | 1KS22CS084 | MONIKA H |
| 23 | 1KS22CS085 | MONIKA V |
| 24 | 1KS22CS086 | MONISHA C |

| | | |
|----|------------|------------------|
| 55 | 1KS22CS117 | RENUKA CHAUDHARY |
| 56 | 1KS22CS118 | REVANTH RAJ P |
| 57 | 1KS22CS119 | RINI JAIN H P |
| 58 | 1KS22CS120 | RUCHITHA S |
| 59 | 1KS22CS121 | RUSHIL RUTHVIGNA |
| 60 | 1KS22CS122 | RUTVIK CHANDRA M |
| 61 | 1KS22CS123 | S HYMA |
| 62 | 1KS22CS124 | S MANOJ |

K.S.INSTITUTE OF TECHNOLOGY

2nd SEM SOFTSKILL TRAINING

DEPARTMENT OF PLACEMENT & PLACEMENTS

CSE- C -SECTION

| SL NO | USN | NAME |
|-------|------------|--------------------------|
| 1 | 1KS22CS125 | SACHIN S KUMBAR |
| 2 | 1KS22CS126 | SAGAR M |
| 3 | 1KS22CS127 | SAHANA C S |
| 4 | 1KS22CS128 | SAI DEEKSHA D |
| 5 | 1KS22CS129 | SAKETH A V |
| 6 | 1KS22CS130 | SAMHITA P |
| 7 | 1KS22CS131 | SAMSKRUTHI S KASHYAP |
| 8 | 1KS22CS132 | SANATH R |
| 9 | 1KS22CS133 | SANDEEP KUMAR JENA |
| 10 | 1KS22CS134 | SANDESH GURURAJ KULLOLLI |
| 11 | 1KS22CS135 | SANGEETHA K M |
| 12 | 1KS22CS136 | SANJANA SURESH TIGADI |
| 13 | 1KS22CS137 | SANKET MATHAPATI |
| 14 | 1KS22CS138 | SATYA KARTHIK R |
| 15 | 1KS22CS139 | SHAMANTH SREEPAD JOSHI |
| 16 | 1KS22CS140 | SHARANUBASAVA ARADHYA |
| 17 | 1KS22CS141 | SHASHANK H Y |
| 18 | 1KS22CS142 | SHASHANKGOUDA G GALI |
| 19 | 1KS22CS143 | SHRAVYA C S |
| 20 | 1KS22CS144 | SHRAVYA R |
| 21 | 1KS22CS145 | SHREEHARI D R |
| 22 | 1KS22CS146 | SHREYA MURTHY |
| 23 | 1KS22CS147 | SHREYA P R |
| 24 | 1KS22CS149 | SINCHANA M |

| | | |
|----|------------|----------------|
| 54 | 1KS22CS179 | VARSHA S N |
| 55 | 1KS22CS180 | VEENA M |
| 56 | 1KS22CS181 | VIDYA K |
| 57 | 1KS22CS182 | VIDYA M S |
| 58 | 1KS22CS183 | VIGNESH B |
| 59 | 1KS22CS184 | VIGNESH S |
| 60 | 1KS22CS185 | VIJAYASHREE A |
| 61 | 1KS22CS186 | VIKRAM S |
| 62 | 1KS22CS187 | VIVEK |
| 63 | 1KS22CS188 | YASHASWINI S L |

K.S.INSTITUTE OF TECHNOLOGY**2nd SEM SOFTSKILL TRAINING****DEPARTMENT OF PLACEMENT & PLACEMENTS****CSD-DEPARTMENT**

| SL.NO | USN | NAME OF THE STUDENT |
|-------|------------|---------------------|
| 1 | IKS22CG001 | ADITHYA P |
| 2 | IKS22CG002 | AJAY H M |
| 3 | IKS22CG003 | AMITA S |
| 4 | IKS22CG004 | ANUDEEP P |
| 5 | IKS22CG005 | ANUSHA P R |
| 6 | IKS22CG006 | BHARATH C |
| 7 | IKS22CG007 | CHAITRA P |
| 8 | IKS22CG008 | CHARAN B |
| 9 | IKS22CG009 | CHARVITA RAO PAVAR |
| 10 | IKS22CG010 | CHIRAG K |
| 11 | IKS22CG011 | DAYANIDHI S |
| 12 | IKS22CG012 | DEEKSHA C |
| 13 | IKS22CG013 | DHANUSH S |
| 14 | IKS22CG014 | E DURGAMAITRI |
| 15 | IKS22CG015 | GOLLA SUKUMAR |
| 16 | IKS22CG016 | HARSHITHA P |
| 17 | IKS22CG017 | HEMANTH C H |
| 18 | IKS22CG018 | HIMANSHU SHARMA |
| 19 | IKS22CG019 | HRUSHIKESH R |
| 20 | IKS22CG020 | JEEVIKA SREE K |
| 21 | IKS22CG021 | JNANASHREE T R |
| 22 | IKS22CG022 | K JAHNAVI CHOWDARY |
| 23 | IKS22CG023 | KUSHAL GOWDA S R |

| | | |
|----|------------|-------------------|
| 52 | IKS22CG052 | SUNILA K |
| 53 | IKS22CG053 | TRIYA HIEMATH |
| 54 | IKS22CG054 | U VINAYAKA PRABHU |
| 55 | IKS22CG055 | UMESH L |
| 56 | IKS22CG056 | V BINDUSHREE |
| 57 | IKS22CG057 | VAISHNAVI A |
| 58 | IKS22CG058 | VENUPRASAD A |
| 59 | IKS22CG059 | VIBHA DATTA |
| 60 | IKS22CG060 | VIVIN VAIBHAV L K |
| 61 | IKS22CG061 | YASHAS S GOWDA |
| 62 | IKS22CG062 | YASHITA B R |

K.S.INSTITUTE OF TECHNOLOGY**2nd SEM SOFTSKILL TRAINING****DEPARTMENT OF PLACEMENT & PLACEMENTS****AIML- DEPARTMENT**

| SL.NO | USN | NAME OF THE STUDENT |
|--------------|------------|-----------------------------------|
| 1 | IKS22AI001 | ABHINAV S BHAT |
| 2 | IKS22AI002 | ADITI B PURANIK |
| 3 | IKS22AI003 | AFRA FURKHEEN |
| 4 | IKS22AI004 | AKASH Y |
| 5 | IKS22AI005 | ANAMIKA |
| 6 | IKS22AI006 | ANUSH R |
| 7 | IKS22AI007 | ANVITHA S BADIGER |
| 8 | IKS22AI008 | ARUN SAGAR GOWDA |
| 9 | IKS22AI009 | AYESHA TASMIYA |
| 11 | IKS22AI010 | BHOOMIKA K |
| 10 | IKS22AI011 | BHAVAN ADITYA M |
| 12 | IKS22AI012 | CHANDANA V |
| 13 | IKS22AI013 | D LIKITHA RAJU |
| 14 | IKS22AI014 | DHANUSH C |
| 15 | IKS22AI015 | GANASHREE K N |
| 16 | IKS22AI016 | GIRISH B H |
| 17 | IKS22AI017 | HARSHA C R |
| 18 | IKS22AI018 | HAYAVADAN MADHWARAJ BELGAUMKAR |
| 19 | IKS22AI019 | HRISHIKESH GANGATKAR |
| 20 | IKS22AI020 | HRISHIKESH JAYAKUMAR |
| 21 | IKS22AI021 | J N SANDEEP |
| 22 | IKS22AI022 | KANDALA JAYANTH |
| 23 | IKS22AI023 | KEERTHANA Y N |
| 24 | IKS22AI024 | M VAISHNAVI |
| 25 | IKS22AI025 | MANOJ H P |
| 26 | IKS22AI026 | MAYUR D YADAV |
| 27 | IKS22AI027 | MUYEEZ AHMED SHARIFF |
| 28 | IKS22AI028 | NANDIGAM SRAVITHA |
| 29 | IKS22AI029 | PALLAVI G |

| K.S.INSTITUTE OF TECHNOLOGY | | |
|--|------------|----------------------|
| 2nd SEM SOFTSKILL TRAINING | | |
| DEPARTMENT OF PLACEMENT & PLACEMENTS | | |
| COMPUTER & COMMUNICATION ENGINEERING +MECHANICAL | | |
| SL.NO | USN | NAME OF THE STUDENT |
| 1 | 1KS22CM001 | ADITHYA ARUN SATHVIK |
| 2 | 1KS22CM002 | ANITHA P C |
| 3 | 1KS22CM003 | ANUSH S |
| 4 | 1KS22CM004 | ARPITHA |
| 5 | 1KS22CM005 | ARSHIYA J |
| 6 | 1KS22CM006 | ARUN L JADAVA LAMANI |
| 7 | 1KS22CM007 | B S AISHWARYA |
| 8 | 1KS22CM008 | B S BRUNDHA |
| 9 | 1KS22CM009 | BASAPUR GOPALKRISHNA |
| 10 | 1KS22CM010 | BASAVARAJ PATIL |
| 11 | 1KS22CM011 | BRINDA S |
| 12 | 1KS22CM012 | DEEKSHA H R |
| 13 | 1KS22CM013 | DEEKSHA S |
| 14 | 1KS22CM014 | DEEPIKA G |
| 15 | 1KS22CM015 | DINESH SHARMA B |
| 16 | 1KS22CM016 | DISHA A |
| 17 | 1KS22CM017 | GANGOTHRI P |
| 18 | 1KS22CM018 | H R CHANDANA |
| 19 | 1KS22CM019 | HAJIRA ANWAR |
| 20 | 1KS22CM020 | HAMEED VAJIR TERDALE |
| 21 | 1KS22CM021 | HEMANTH B R |
| 22 | 1KS22CM022 | HEMANTH K E |
| 23 | 1KS22CM023 | K R SHREYA |
| 24 | 1KS22CM024 | KARTHIK R JOSHI |
| 25 | 1KS22CM025 | KIRAN D |
| 26 | 1KS22CM026 | KUNDANKUMAR S |
| 27 | 1KS22CM027 | MAHALAKSHMI D |
| 28 | 1KS22CM028 | MANJUNATH K |
| 29 | 1KS22CM030 | MOHAMMED FAHIM R |
| 30 | 1KS22CM031 | NARASIMHA M K |
| 31 | 1KS22CM032 | NEELANJALI C |
| 32 | 1KS22CM033 | NIMISHA S L |

| K.S.INSTITUTE OF TECHNOLOGY | | |
|--------------------------------------|------------|----------------------|
| 2nd SEM SOFTSKILL TRAINING | | |
| DEPARTMENT OF PLACEMENT & PLACEMENTS | | |
| IOT-DEPARTMENT | | |
| SL.NO | USN | NAME OF THE STUDENT |
| 1 | 1KS22IC001 | A SHRIYA |
| 2 | 1KS22IC002 | AARADHANA R |
| 3 | 1KS22IC003 | ABHIRAM SAMARTHA T R |
| 4 | 1KS22IC004 | ANUSHA A S |
| 5 | 1KS22IC005 | ARNAV P |
| 6 | 1KS22IC006 | BHAVANA N |
| 7 | 1KS22IC007 | BHAVYA P |
| 8 | 1KS22IC008 | C LITHISH |
| 9 | 1KS22IC009 | D AKSHAY KUMAR |
| 10 | 1KS22IC010 | DABBARA ADITHYA |
| 11 | 1KS22IC011 | DARSHAN M |
| 12 | 1KS22IC012 | DEEKSHITHA S A |
| 13 | 1KS22IC013 | GAGANDEEP NAIDU L |
| 14 | 1KS22IC014 | HOYSALA Y DEVANGA |
| 15 | 1KS22IC015 | H P DARSHAN URS |
| 16 | 1KS22IC016 | J YAGNESH ANUGA |
| 17 | 1KS22IC017 | JAHNAVI C |
| 18 | 1KS22IC018 | JETTI GOUTHAM |
| 19 | 1KS22IC019 | K M ANIL KUMAR |
| 20 | 1KS22IC020 | KOUSHAL K NAYAK |
| 21 | 1KS22IC021 | L MANEESH |
| 22 | 1KS22IC022 | LEENA J |
| 23 | 1KS22IC023 | MAHIMA A |
| 24 | 1KS22IC024 | MOHITH K |
| 25 | 1KS22IC025 | MOUSHAMI D |
| 26 | 1KS22IC026 | NISHANTH R |
| 27 | 1KS22IC027 | NISHMITHA SHETTY B S |
| 28 | 1KS22IC028 | NITHYASHREE K S |
| 29 | 1KS22IC029 | P SHROUMITH SIMHA |
| 30 | 1KS22IC030 | PALETI THIMMARAJU |
| 31 | 1KS22IC031 | PATHAKAMURI SUDEEPHI |
| 32 | 1KS22IC032 | PRANAMYA K L |
| 33 | 1KS22IC033 | PRANAV MUDGAL |

| K.S.INSTITUTE OF TECHNOLOGY | | |
|--------------------------------------|------------|----------------------------------|
| 2nd SEM SOFTSKILL TRAINING | | |
| DEPARTMENT OF PLACEMENT & PLACEMENTS | | |
| ECE-A -SECTION | | |
| SL.NO | USN | NAME OF THE STUDENT |
| 1 | IKS22EC001 | ABINAY |
| 2 | IKS22EC002 | ADEEBA ISMATH |
| 3 | IKS22EC003 | ADITH PINNEPALLI |
| 4 | IKS22EC004 | ADITHYA S |
| 5 | IKS22EC005 | AJITH D |
| 6 | IKS22EC006 | AKASH S |
| 7 | IKS22EC007 | AMRUTHA P |
| 8 | IKS22EC008 | AMULYA M N |
| 9 | IKS22EC009 | ANAGHA K S |
| 10 | IKS22EC010 | ANKIT PRAKASH |
| 11 | IKS22EC011 | ANKITA BUDNI |
| 12 | IKS22EC012 | ANUPRIYA T |
| 13 | IKS22EC013 | ANUSHA MALIPATIL |
| 14 | IKS22EC014 | ARCHANA M |
| 15 | IKS22EC015 | ARCHANA N |
| 16 | IKS22EC016 | ARCHANA S K |
| 17 | IKS22EC017 | ASHOK |
| 18 | IKS22EC018 | ASHWINI P |
| 19 | IKS22EC019 | AVINASH |
| 20 | IKS22EC020 | AYYAJI MADHAVA H N |
| 21 | IKS22EC021 | BHOOMIKA D |
| 22 | IKS22EC022 | C RAHUL |
| 23 | IKS22EC023 | CHERUKURU HARIKA |
| 24 | IKS22EC024 | CHETAN S P |
| 25 | IKS22EC025 | CHETHAN A G |
| 26 | IKS22EC026 | CHIDAMBAR PRABHAKAR MUNAVALLI |
| 27 | IKS22EC027 | CHINMAY SHEELVANT |
| 28 | IKS22EC028 | D N MITHUN |
| 29 | IKS22EC029 | DARAPANENI ARUN CHOWDARY |
| 30 | IKS22EC030 | DARSHAN GOWDA M K |
| 31 | IKS22EC031 | DEEKSHA S REDDY |
| 32 | IKS22EC032 | DEEKSHA T S |
| 33 | IKS22EC033 | DINESH N |

K.S.INSTITUTE OF TECHNOLOGY**2nd SEM SOFTSKILL TRAINING****DEPARTMENT OF PLACEMENT & PLACEMENTS****ECE-B SECTION**

| SL NO | USN | NAME |
|--------------|------------|------------------------------|
| 1 | 1KS22EC064 | MEGHARAJ C M |
| 2 | 1KS22EC065 | MOHAMMED TAHA |
| 3 | 1KS22EC066 | MONIKA H N |
| 4 | 1KS22EC067 | MONISHA B N |
| 5 | 1KS22EC068 | NALLANI HEMA |
| 6 | 1KS22EC069 | NEHA M |
| 7 | 1KS22EC070 | NISARGA M |
| 8 | 1KS22EC071 | NITHYASHREE V L |
| 9 | 1KS22EC072 | PAVANA C |
| 10 | 1KS22EC073 | POOJA V |
| 11 | 1KS22EC074 | PRAJWAL P |
| 12 | 1KS22EC075 | PRANAV RAJATH |
| 13 | 1KS22EC076 | PREKSHITHA S |
| 14 | 1KS22EC077 | RACHANA JAGANNATH |
| 15 | 1KS22EC078 | RAGHU H M |
| 16 | 1KS22EC079 | RAKSHITA M B |
| 17 | 1KS22EC080 | RANJITH GOWDA K |
| 18 | 1KS22EC081 | ROHITH D YADAV |
| 19 | 1KS22EC082 | ROHITH M |
| 20 | 1KS22EC083 | SACHIN BASAPPA BABANNAVAR |

| | | |
|----|------------|--|
| 46 | 1KS22EC109 | UMME SARA |
| 47 | 1KS22EC110 | V LIKHITH |
| 48 | 1KS22EC111 | VARDHAN GOWDA K N |
| 49 | 1KS22EC112 | VARSHA B C |
| 50 | 1KS22EC113 | VARSHINI S |
| 51 | 1KS22EC114 | VARUN |
| 52 | 1KS22EC115 | VARUN RAYAPATI R |
| 53 | 1KS22EC116 | VEDASHREE M |
| 54 | 1KS22EC117 | VIDYASHREE H |
| 55 | 1KS22EC118 | VIJAYKUMAR SHANMUKHAYYA NAVALAGIMATH |
| 56 | 1KS22EC119 | VIKAS K S |
| 57 | 1KS22EC120 | VISHWANATH B S |
| 58 | 1KS22EC121 | VISHWANATH VEERAPUR |
| 59 | 1KS22EC122 | VISHWAS M K |
| 60 | 1KS22EC123 | VIVEK M S |
| 61 | 1KS22EC124 | VIVEK RAJ B |
| 62 | 1KS22EC125 | YASHAVANTHA S |
| 63 | 1KS22EC126 | YASHWANTH P V |

K S INSTITUTE OF TECHNOLOGY

DEPARTMENT OF TRAINING AND PLACEMENTS

CONSOLIDATED ATTENDANCE FOR SOFT SKILL TRAINING

| I YEAR -CSE-A- SECTION | | | 2nd SEMESTER | | | | | | BATCH I (NB-101) | | | | | | | | |
|------------------------|---------------------|------------|--------------|---|---|------------|---|---|-------------------|---|---|------------|----|----|------------|----|----|
| S.L No | NAME OF THE STUDENT | USN | Dates | | | | | | | | | | | | | | |
| | | | 03/08/23 | | | 04/08/2023 | | | 05/08/2023 | | | 07/08/2023 | | | 08/08/2023 | | |
| | | | 1 | 2 | 3 | 4 | 5 | 6 | 7 | 8 | 9 | 10 | 11 | 12 | 13 | 14 | 15 |
| 1 | ABENI B | 1KS22CS001 | 1 | 2 | 3 | 4 | 5 | 6 | 7 | 8 | 9 | 10 | 11 | 12 | 13 | 14 | 15 |
| 2 | ABHISHEK A | 1KS22CS002 | 1 | 2 | 3 | 4 | 5 | 6 | 7 | 8 | 9 | 10 | 11 | 12 | 13 | A | A |
| 3 | ACHYUTHA UN | 1KS22CS003 | 1 | 2 | 3 | 4 | A | 5 | 6 | 7 | 8 | 9 | 10 | 11 | 12 | 13 | 14 |
| 4 | ADITHYA M | 1KS22CS004 | A | A | A | A | A | A | 1 | 2 | 3 | 4 | 5 | 6 | 7 | 8 | 9 |
| 5 | ADITYA S | 1KS22CS005 | 1 | 2 | 3 | 4 | 5 | 6 | 7 | 8 | 9 | 10 | 11 | 12 | 13 | 14 | 15 |
| 6 | ADITYA VENKATESH | 1KS22CS006 | 1 | 2 | 3 | 4 | 5 | 6 | 7 | 8 | 9 | 10 | 11 | 12 | 13 | 14 | 15 |
| 7 | AKASH JADHAV | 1KS22CS007 | 1 | 2 | 3 | 4 | 5 | 6 | A | A | A | 7 | 8 | 9 | 10 | 11 | 12 |
| 8 | AKASH S R | 1KS22CS008 | 1 | 2 | 3 | 4 | 5 | 6 | 7 | 8 | 9 | 10 | 11 | 12 | 13 | 14 | 15 |
| 9 | AKSHAY KRISHNA K S | 1KS22CS009 | 1 | 2 | 3 | 4 | 5 | 6 | 7 | 8 | 9 | 10 | 11 | 12 | 13 | 14 | 15 |
| 10 | AMRUTHA N | 1KS22CS010 | 1 | 2 | 3 | 4 | 5 | 6 | 7 | 8 | 9 | 10 | 11 | 12 | 13 | 14 | 15 |
| 11 | ANANYA C | 1KS22CS011 | 1 | 2 | 3 | 4 | 5 | 6 | 7 | 8 | A | 9 | 10 | 11 | 12 | 13 | 14 |
| 12 | ANANYA S | 1KS22CS012 | 1 | 2 | 3 | 4 | 5 | 6 | 7 | 8 | 9 | 10 | 11 | 12 | 13 | 14 | 15 |
| 13 | ADONI ANIRUDH | 1KS22CS013 | A | A | A | A | A | A | A | A | A | A | A | A | A | A | A |
| 14 | ANIRUDH SURESH | 1KS22CS014 | A | A | A | 1 | 2 | 3 | 4 | 5 | A | 6 | 7 | 8 | 9 | 10 | 11 |
| 15 | ANIRUDH.M.M UDAMBI | 1KS22CS015 | 1 | 2 | 3 | 4 | A | 5 | 6 | 7 | 8 | 9 | 10 | 11 | A | A | A |
| 16 | ANKITA N | 1KS22CS016 | 1 | 2 | 3 | 4 | 5 | 6 | 7 | 8 | 9 | 10 | 11 | 12 | 13 | 14 | 15 |
| 17 | ANMOL NAIK S | 1KS22CS017 | 1 | 2 | 3 | 4 | 5 | 6 | 7 | 8 | 9 | 10 | 11 | 12 | 13 | 14 | 15 |
| 18 | ANUKA KIRANA | 1KS22CS018 | 1 | 2 | 3 | 4 | 5 | 6 | 7 | 8 | 9 | 10 | 11 | 12 | 13 | 14 | 15 |

| | | | | | | | | | | | | | | | | | |
|----|----------------------|------------|---|---|---|---|---|---|---|---|---|----|----|----|----|----|----|
| 19 | ANUSHKA SHRIPAD | 1KS22CS019 | A | A | A | 1 | 2 | 3 | 4 | 5 | 6 | 7 | 8 | 9 | 10 | 11 | 12 |
| 20 | ANVITHA M V | 1KS22CS020 | 1 | 2 | 3 | 4 | 5 | 6 | 7 | 8 | 9 | 10 | 11 | 12 | 13 | 14 | 15 |
| 21 | ARJAV C PRABHU | 1KS22CS021 | 1 | 2 | 3 | 4 | 5 | 6 | 7 | 8 | 9 | 10 | 11 | 12 | 13 | 14 | 15 |
| 22 | ARNAV HANGAL | 1KS22CS022 | 1 | 2 | 3 | 4 | 5 | 6 | 7 | 8 | 9 | A | A | A | 10 | 11 | 12 |
| 23 | ASHISH REDDY V P | 1KS22CS023 | 1 | 2 | 3 | 4 | 5 | 6 | A | A | A | A | A | A | A | A | A |
| 24 | B S VARSHA | 1KS22CS024 | 1 | 2 | 3 | 4 | 5 | 6 | 7 | 8 | 9 | 10 | 11 | 12 | 13 | 14 | 15 |
| 25 | BALAJI R | 1KS22CS025 | A | A | A | A | A | A | A | A | A | A | A | A | A | A | A |
| 26 | BHARATH M | 1KS22CS026 | 1 | 2 | 3 | 4 | 5 | 6 | 7 | 8 | 9 | 10 | 11 | 12 | 13 | 14 | 15 |
| 27 | BHUVAN M | 1KS22CS027 | 1 | 2 | 3 | 4 | A | 5 | 6 | 7 | 8 | 9 | 10 | 11 | 12 | 13 | 14 |
| 28 | BINDU M | 1KS22CS028 | 1 | 2 | 3 | A | A | A | A | A | 4 | 5 | 6 | 7 | 8 | 9 | |
| 29 | BINDU SHREE B | 1KS22CS029 | 1 | 2 | 3 | 4 | 5 | 6 | 7 | 8 | 9 | 10 | 11 | 12 | 13 | 14 | 15 |
| 30 | CHAITHANYA B S | 1KS22CS030 | 1 | 2 | 3 | 4 | 5 | 6 | 7 | 8 | 9 | 10 | 11 | 12 | 13 | 14 | 15 |
| 31 | CHAITRA E KODIGOUDRA | 1KS22CS031 | 1 | 2 | 3 | 4 | 5 | 6 | 7 | 8 | 9 | 10 | 11 | 12 | 13 | 14 | 15 |
| 32 | CHARITHANJA L M | 1KS22CS032 | 1 | 2 | 3 | 4 | 5 | 6 | 7 | 8 | 9 | 10 | 11 | 12 | 13 | 14 | 15 |
| 33 | CHETHAN M | 1KS22CS033 | 1 | 2 | 3 | 4 | 5 | 6 | 7 | 8 | 9 | 10 | 11 | 12 | 13 | 14 | 15 |
| 34 | CHIRAG K P | 1KS22CS034 | 1 | 2 | 3 | 4 | 5 | 6 | 7 | 8 | 9 | 10 | 11 | 12 | 13 | 14 | 15 |
| 35 | CHIRANJEEVI T M | 1KS22CS035 | 1 | 2 | 3 | 4 | 5 | 6 | 7 | 8 | 9 | A | 10 | 11 | 12 | 13 | 14 |
| 36 | D S AISHWARYA | 1KS22CS036 | 1 | 2 | 3 | 4 | 5 | 6 | 7 | 8 | 9 | 10 | 11 | 12 | 13 | 14 | 15 |
| 37 | DARSHAN D GOWDA | 1KS22CS037 | 1 | 2 | 3 | 4 | 5 | 6 | 7 | 8 | 9 | 10 | 11 | 12 | 13 | 14 | 15 |
| 38 | DEEKSHA S | 1KS22CS038 | 1 | 2 | 3 | 4 | 5 | 6 | 7 | 8 | 9 | 10 | 11 | 12 | 13 | 14 | 15 |
| 39 | DEEPIKA ANGEL K | 1KS22CS039 | 1 | 2 | 3 | 4 | 5 | 6 | 7 | 8 | 9 | 10 | 11 | 12 | 13 | 14 | 15 |
| 40 | DEEPTHI B | 1KS22CS040 | 1 | 2 | 3 | 4 | 5 | 6 | 7 | 8 | 9 | 10 | 11 | 12 | 13 | 14 | 15 |
| 41 | DIVYASHREE S | 1KS22CS041 | 1 | 2 | 3 | 4 | 5 | 6 | 7 | 8 | 9 | 10 | 11 | 12 | 13 | 14 | 15 |
| 42 | DUVVUR DARSHAN | 1KS22CS042 | 1 | 2 | 3 | 4 | 5 | 6 | 7 | 8 | 9 | 10 | 11 | 12 | 13 | 14 | 15 |
| 43 | GAGAN GOWDA B G | 1KS22CS043 | 1 | 2 | 3 | 4 | A | 5 | 6 | 7 | A | 8 | 9 | 10 | 11 | 12 | 13 |

| | | | | | | | | | | | | | | | | | |
|--|----------------------|------------|----|----|----|----|----|----|----|----|----|----|----|----|----|----|----|
| 44 | GAURAV NANDAN | 1KS22CS044 | 1 | 2 | 3 | 4 | 5 | 6 | A | A | A | 7 | 8 | 9 | 10 | 11 | 12 |
| 45 | GNANESH S | 1KS22CS045 | 1 | 2 | 3 | 4 | A | 5 | 6 | 7 | 8 | 9 | 10 | A | A | A | A |
| 46 | GUNITH RAVIKIRAN | 1KS22CS046 | 1 | 2 | 3 | 4 | 5 | 6 | 7 | 8 | 9 | 10 | 11 | 12 | 13 | 14 | 15 |
| 47 | GURURAJ V A | 1KS22CS047 | 1 | 2 | 3 | 4 | 5 | 6 | 7 | 8 | 9 | 10 | 11 | 12 | 13 | 14 | 15 |
| 48 | HARCHITHA M | 1KS22CS048 | 1 | 2 | 3 | 4 | 5 | 6 | 7 | 8 | 9 | 10 | 11 | 12 | 13 | 14 | 15 |
| 49 | HARSHADITH YA G V | 1KS22CS049 | 1 | 2 | 3 | 4 | 5 | 6 | 7 | 8 | 9 | 10 | 11 | 12 | 13 | 14 | 15 |
| 50 | HEMAMBHIKA B N | 1KS22CS050 | 1 | 2 | 3 | 4 | 5 | 6 | 7 | 8 | 9 | 10 | 11 | 12 | A | A | A |
| 51 | HIMASHWETH A K G | 1KS22CS051 | 1 | 2 | 3 | 4 | 5 | 6 | 7 | 8 | 9 | 10 | 11 | 12 | 13 | 14 | 15 |
| 52 | ISHA MAJI | 1KS22CS052 | 1 | 2 | 3 | 4 | 5 | 6 | 7 | 8 | 9 | 10 | 11 | 12 | 13 | 14 | 15 |
| 53 | JAHNAVI J H | 1KS22CS053 | 1 | 2 | 3 | 4 | 5 | 6 | A | A | A | 7 | 8 | 9 | 10 | 11 | 12 |
| 54 | JAYASHREE KUMAR | 1KS22CS054 | A | A | A | 1 | 2 | 3 | 4 | 5 | 6 | 7 | 8 | 9 | 10 | 11 | 12 |
| 55 | JYOTHSNA R | 1KS22CS055 | 1 | 2 | 3 | 4 | 5 | 6 | 7 | 8 | 9 | 10 | 11 | 12 | 13 | 14 | 15 |
| 56 | K M THEJDEEP | 1KS22CS056 | A | A | A | 1 | 2 | 3 | A | 4 | 5 | A | A | A | A | A | A |
| 57 | KAMNOOR ADITYA | 1KS22CS057 | 1 | 2 | 3 | 4 | 5 | 6 | 7 | 8 | 9 | 10 | 11 | 12 | 13 | 14 | 15 |
| 58 | KARABASAVV A SUBHASA | 1KS22CS058 | 1 | 2 | 3 | 4 | 5 | 6 | 7 | 8 | 9 | 10 | 11 | 12 | 13 | 14 | 15 |
| 59 | KARTHIK KUMAR R | 1KS22CS059 | 1 | 2 | 3 | 4 | 5 | A | 6 | 7 | 8 | 9 | 10 | 11 | 12 | 13 | 14 |
| 60 | KARTHIK V | 1KS22CS060 | 1 | 2 | 3 | 4 | 5 | 6 | 7 | 8 | 9 | 10 | 11 | 12 | 13 | 14 | 15 |
| 61 | KAVITA REVANAPPA | 1KS22CS061 | 1 | 2 | 3 | 4 | 5 | 6 | 7 | 8 | 9 | 10 | 11 | 12 | 13 | 14 | 15 |
| 62 | KIRAN C P | 1KS22CS062 | A | A | A | A | 1 | 2 | 3 | 4 | 5 | A | A | A | 6 | 7 | 8 |
| | | | | | | | | | | | | | | | | | |
| NO OF STUDENTS ABSENT | | | 8 | 8 | 8 | 5 | 9 | 5 | 8 | 7 | 10 | 7 | 6 | 7 | 7 | 8 | 8 |
| NO OF STUDENTS PRESENT | | | 54 | 54 | 54 | 57 | 53 | 57 | 54 | 55 | 52 | 55 | 56 | 55 | 55 | 54 | 54 |
| SIGNATURE OF THE TRAINER/ CLASS TEACHER/ PLACEMENT | | | | | | | | | | | | | | | | | |

9:30 am
11:30 am
3:15 pm

| K S INSTITUTE OF TECHNOLOGY | | | | | | | | | | | | | | | | | |
|---|-----------------------|------------|--------------|---|---|------------|---|---|-------------------|---|---|------------|----|----|------------|----|----|
| DEPARTMENT OF TRAINING AND PLACEMENTS | | | | | | | | | | | | | | | | | |
| CONSOLIDATED ATTENDANCE FOR SOFT SKILL TRAINING | | | | | | | | | | | | | | | | | |
| I YEAR -CSE-B- SECTION | | | 2nd SEMESTER | | | | | | BATCH 2 (NB-102) | | | | | | | | |
| S. No | NAME OF THE STUDENT | USN | Dates | | | | | | | | | | | | | | |
| | | | 03/08/23 | | | 04/08/2023 | | | 05/08/2023 | | | 07/08/2023 | | | 08/08/2023 | | |
| | | | 1 | 2 | 3 | 4 | 5 | 6 | 7 | 8 | 9 | 10 | 11 | 12 | 13 | 14 | 15 |
| 1 | KRUTHANVA R | 1KS22CS063 | 1 | 2 | 3 | 4 | 5 | 6 | 7 | 8 | 9 | 10 | 11 | 12 | 13 | 14 | 15 |
| 2 | KUSHI M | 1KS22CS064 | 1 | 2 | 3 | 4 | 5 | 6 | 7 | 8 | 9 | 10 | 11 | 12 | 13 | 14 | 15 |
| 3 | L DEEKSHA | 1KS22CS065 | 1 | 2 | 3 | 4 | 5 | 6 | 7 | 8 | 9 | 10 | 11 | 12 | 13 | 14 | 15 |
| 4 | L SHREYAS SRINIVAS | 1KS22CS066 | 1 | 2 | 3 | 4 | 5 | 6 | 7 | 8 | 9 | 10 | 11 | 12 | 13 | 14 | 15 |
| 5 | LAKSHMI SHREE K P | 1KS22CS067 | 1 | 2 | 3 | 4 | 5 | 6 | 7 | 8 | 9 | 10 | 11 | 12 | 13 | 14 | 15 |
| 6 | LALITHYA S | 1KS22CS068 | 1 | 2 | 3 | 4 | 5 | 6 | 7 | 8 | 9 | 10 | 11 | 12 | 13 | 14 | 15 |
| 7 | LEKHNA L | 1KS22CS069 | 1 | 2 | 3 | 4 | 5 | 6 | 7 | 8 | 9 | 10 | 11 | 12 | 13 | 14 | 15 |
| 8 | LIKHITH K | 1KS22CS070 | 1 | 2 | 3 | 4 | 5 | 6 | A | A | A | 7 | 8 | 9 | 10 | 11 | 12 |
| 9 | LIPIKA J | 1KS22CS071 | 1 | 2 | 3 | 4 | 5 | 6 | 7 | 8 | 9 | 10 | 11 | 12 | 13 | 14 | 15 |
| 10 | M ASHRITHA | 1KS22CS072 | A | 1 | 2 | 3 | 4 | 5 | 6 | 7 | 8 | 9 | 10 | 11 | 12 | 13 | 14 |
| 11 | M N AMOGH ATHREYA | 1KS22CS073 | A | A | A | 1 | 2 | 3 | 4 | 5 | 6 | 7 | 8 | 9 | 10 | 11 | 12 |
| 12 | MADDURI YAVANIKA | 1KS22CS074 | 1 | 2 | 3 | 4 | 5 | 6 | 7 | 8 | 9 | 10 | 11 | 12 | 13 | 14 | 15 |
| 13 | MALLIKARJUN K S | 1KS22CS075 | 1 | 2 | 3 | 4 | 5 | 6 | 7 | 8 | 9 | 10 | 11 | 12 | 13 | 14 | 15 |
| 14 | MANASVI H Y | 1KS22CS076 | 1 | 2 | 3 | 4 | 5 | A | 6 | 7 | 8 | A | A | A | 9 | 10 | 11 |
| 15 | MANOJA G V | 1KS22CS077 | 1 | 2 | 3 | 4 | 5 | 6 | 7 | 8 | 9 | 10 | 11 | A | 12 | 13 | 14 |
| 16 | MEGHA S | 1KS22CS078 | 1 | 2 | 3 | 4 | 5 | 6 | 7 | 8 | 9 | 10 | 11 | 12 | 13 | 14 | 15 |
| 17 | MINAKSHI ANIL BADIGER | 1KS22CS079 | 1 | 2 | 3 | 4 | 5 | 6 | 7 | 8 | 9 | 10 | 11 | 12 | 13 | 14 | 15 |
| 18 | MISBA SABA | 1KS22CS080 | A | 1 | 2 | 3 | 4 | A | 5 | A | A | 6 | 7 | 8 | 9 | 10 | 11 |
| 19 | MOHAMMED TAHIR | 1KS22CS081 | 1 | 2 | 3 | A | A | A | A | 4 | 5 | 6 | 7 | 8 | 9 | 10 | |
| 20 | MOHAMMED YAHYA NAZIM | 1KS22CS082 | 1 | 2 | 3 | 4 | 5 | 6 | 7 | 8 | 9 | 10 | 11 | 12 | 13 | 14 | 15 |
| 21 | MOKESH G R | 1KS22CS083 | 1 | 2 | 3 | 4 | 5 | 6 | 7 | 7 | 8 | 9 | 10 | 11 | 12 | 13 | 14 |
| 22 | MONIKA H | 1KS22CS084 | A | 1 | 2 | 3 | 4 | 5 | 6 | 8 | 9 | 10 | 11 | 12 | 13 | 14 | 15 |
| 23 | MONIKA.V | 1KS22CS085 | 1 | 2 | 3 | 4 | 5 | 6 | 7 | 8 | 9 | 10 | 11 | 12 | 13 | 14 | 15 |

| | | | | | | | | | | | | | | | | | |
|----|----------------------|------------|---|---|---|---|---|---|---|---|---|----|----|----|----|----|----|
| 24 | MONISHA C | 1KS22CS086 | 1 | 2 | 3 | 4 | 5 | 6 | A | A | 7 | 8 | 9 | 10 | 11 | 12 | |
| 25 | NAGAMAHESH KENDOLE | 1KS22CS087 | 1 | 2 | 3 | 4 | 5 | 6 | 7 | 8 | 9 | 10 | 11 | 12 | 13 | 14 | 15 |
| 26 | NAGAMMA | 1KS22CS088 | A | A | A | 1 | 2 | 3 | 4 | 5 | 6 | 7 | 8 | 9 | 10 | 11 | 12 |
| 27 | NAGARJUN KUMAR S | 1KS22CS089 | 1 | 2 | 3 | 4 | 5 | 6 | 7 | 8 | 9 | A | 10 | 11 | 12 | 13 | 14 |
| 28 | NARESH KUMAR N | 1KS22CS090 | 1 | 2 | 3 | 4 | 5 | 6 | 7 | 8 | 9 | 10 | 11 | 12 | 13 | 14 | 15 |
| 29 | NAWAZ KHAN | 1KS22CS091 | 1 | 2 | 3 | 4 | 5 | 6 | 7 | 8 | 9 | 10 | 11 | 12 | 13 | 14 | 15 |
| 30 | NAYANA R | 1KS22CS092 | 1 | 2 | 3 | 4 | 5 | 6 | 7 | 8 | 9 | 10 | 11 | 12 | 13 | 14 | 15 |
| 31 | NEHA V | 1KS22CS093 | 1 | 2 | 3 | 4 | 5 | 6 | 7 | 8 | 9 | 10 | 11 | 12 | 13 | 14 | 15 |
| 32 | NITHIN R | 1KS22CS094 | 1 | 2 | 3 | 4 | 5 | 6 | 7 | 8 | 9 | 10 | 11 | 12 | 13 | 14 | 15 |
| 33 | P C TEJAS | 1KS22CS095 | 1 | 2 | 3 | 4 | 5 | 6 | 7 | 8 | 9 | 10 | 11 | 12 | 13 | 14 | 15 |
| 34 | PAAVANA P | 1KS22CS096 | 1 | 2 | 3 | 4 | 5 | 6 | 7 | 8 | 9 | 10 | 11 | 12 | 13 | 14 | 15 |
| 35 | PALLAVI C | 1KS22CS097 | 1 | 2 | 3 | 4 | 5 | 6 | 7 | 8 | 9 | 10 | 11 | 12 | 13 | 14 | 15 |
| 36 | PALLAVI S | 1KS22CS098 | 1 | 2 | 3 | 4 | 5 | 6 | 7 | 8 | 9 | 10 | 11 | 12 | 13 | 14 | 15 |
| 37 | PANCHAMI L | 1KS22CS099 | 1 | 2 | A | 3 | 4 | 5 | 6 | 7 | 9 | 10 | 11 | 12 | 13 | 14 | 15 |
| 38 | PARVEZ ANSARI | 1KS22CS100 | A | 1 | 2 | 3 | 4 | 5 | 6 | 7 | 9 | 10 | 11 | A | 12 | 13 | 14 |
| 39 | PASUPULETI SRAVYA | 1KS22CS101 | 1 | 2 | 3 | 4 | 5 | 6 | 7 | 8 | 9 | 10 | 11 | 12 | 13 | 14 | 15 |
| 40 | POOJITHA J N | 1KS22CS102 | 1 | 2 | 3 | 4 | 5 | 6 | 7 | 8 | 9 | 10 | 11 | 12 | 13 | 14 | 15 |
| 41 | POONAM SINGH A | 1KS22CS103 | 1 | 2 | 3 | 4 | 5 | 6 | 7 | 8 | 9 | 10 | 11 | 12 | 13 | 14 | 15 |
| 42 | PRAJNA ANANT GAONKAR | 1KS22CS104 | 1 | 2 | 3 | 4 | 5 | 6 | 7 | 8 | 9 | 10 | 11 | 12 | 13 | 14 | 15 |
| 43 | PRAKRUTHI G P | 1KS22CS105 | 1 | 2 | 3 | 4 | 5 | 6 | 7 | 8 | 9 | 10 | 11 | 12 | 13 | 14 | 15 |
| 44 | PRANAV B R | 1KS22CS106 | 1 | 2 | 3 | 4 | 5 | 6 | 7 | 8 | 9 | 10 | 11 | 12 | 13 | 14 | 15 |
| 45 | PREETHAL DSOUZA | 1KS22CS107 | 1 | 2 | 3 | 4 | 5 | 6 | 7 | 8 | 9 | 10 | 11 | 12 | 13 | 14 | 15 |
| 46 | PRUTHU K L | 1KS22CS108 | 1 | 2 | 3 | 4 | 5 | 6 | 7 | 8 | 9 | 10 | 11 | A | 12 | 13 | 14 |
| 47 | PUNEETH VEMURI | 1KS22CS109 | 1 | 2 | 3 | 4 | 5 | 6 | 7 | 8 | 9 | 10 | 11 | 12 | 13 | 14 | 15 |
| 48 | R CHENDRA CHUDA | 1KS22CS110 | 1 | 2 | 3 | 4 | 5 | 6 | 7 | 8 | 9 | 10 | 11 | 12 | 13 | 14 | 15 |
| 49 | RACHANA N | 1KS22CS111 | 1 | 2 | 3 | 4 | 5 | 6 | 7 | 8 | 9 | 10 | 11 | 12 | 13 | 14 | 15 |
| 50 | RAGHUSAI ACHUTH | 1KS22CS112 | 1 | 2 | 3 | A | A | A | A | A | A | A | A | A | A | A | A |
| 51 | RAKSHITA A U | 1KS22CS113 | 1 | 2 | 3 | 4 | 5 | 6 | 7 | 8 | 9 | 10 | 11 | 12 | 13 | 14 | 15 |
| 52 | RAKSHITHA J | 1KS22CS114 | 1 | 2 | 3 | 4 | 5 | 6 | 7 | 8 | 9 | 10 | 11 | 12 | 13 | 14 | 15 |
| 53 | RAKSHITHA R | 1KS22CS115 | 1 | 2 | 3 | 4 | 5 | 6 | 7 | 8 | 9 | 10 | 11 | 12 | 13 | 14 | 15 |

9:00 AM
11:30 AM
3:15 PM

| K S INSTITUTE OF TECHNOLOGY | | | | | | | | | | | | | | | | | |
|---|--------------------------|------------|--------------|---|---|------------|---|---|-------------------|---|---|------------|----|----|------------|----|----|
| DEPARTMENT OF TRAINING AND PLACEMENTS | | | | | | | | | | | | | | | | | |
| CONSOLIDATED ATTENDANCE FOR SOFT SKILL TRAINING | | | | | | | | | | | | | | | | | |
| 1 YEAR -CSE-C- SECTION | | | 2nd SEMESTER | | | | | | BATCH 3 (NB-104) | | | | | | | | |
| S. No | NAME OF THE STUDENT | USN | Dates | | | | | | | | | | | | | | |
| | | | 03/08/23 | | | 04/08/2023 | | | 05/08/2023 | | | 07/08/2023 | | | 08/08/2023 | | |
| | | | 1 | 2 | 3 | 4 | 5 | 6 | 7 | 8 | 9 | 10 | 11 | 12 | 13 | 14 | 15 |
| SL NO | USN | NAME | | | | | | | | | | | | | | | |
| 1 | SAGAR M | 1KS22CS126 | 1 | 2 | 3 | 4 | 5 | 6 | 7 | 8 | 9 | 10 | 11 | 12 | 13 | 14 | 15 |
| 2 | SAHANA C S | 1KS22CS127 | 1 | 2 | 3 | 4 | 5 | 6 | 7 | 8 | 9 | 10 | 11 | 12 | 13 | 14 | 15 |
| 3 | SAI DEEKSHA D | 1KS22CS128 | 1 | 2 | 3 | 4 | 5 | 6 | 7 | 8 | 9 | 10 | 11 | 12 | 13 | 14 | 15 |
| 4 | SAKETH A V | 1KS22CS129 | 1 | 2 | 3 | 4 | 5 | 6 | 7 | 8 | 9 | 10 | 11 | 12 | 13 | 14 | 15 |
| 5 | SAMHITA P | 1KS22CS130 | 1 | 2 | 3 | 4 | 5 | 6 | 7 | 8 | 9 | 10 | 11 | 12 | 13 | 14 | 15 |
| 6 | SAMSKRUTHI S KASHYAP | 1KS22CS131 | 1 | 2 | 3 | A | A | A | 4 | 5 | 6 | 7 | 8 | 9 | 10 | 11 | 12 |
| 7 | SANATH R | 1KS22CS132 | 1 | 2 | 3 | 4 | 5 | 6 | 7 | 8 | 9 | A | A | A | A | A | A |
| 8 | SANDEEP KUMAR JENA | 1KS22CS133 | 1 | 2 | 3 | 4 | 5 | 6 | 7 | 8 | 9 | 10 | 11 | 12 | 13 | 14 | 15 |
| 9 | SANDESH GURURAJ KULLOLLI | 1KS22CS134 | 1 | 2 | 3 | 4 | 5 | 6 | A | 7 | 8 | 9 | 10 | 11 | 12 | 13 | 14 |
| 10 | SANGEETHA K M | 1KS22CS135 | 1 | 2 | 3 | 4 | 5 | 6 | 7 | 8 | 9 | A | A | A | A | A | A |
| 11 | SANJANA SURESH TIGADI | 1KS22CS136 | 1 | 2 | 3 | 4 | 5 | 6 | 7 | 8 | 9 | 10 | 11 | 12 | 13 | 14 | 15 |
| 12 | SANKET MATHAPATI | 1KS22CS137 | 1 | 2 | 3 | 4 | 5 | 6 | A | 7 | 8 | 9 | 10 | 11 | 12 | 13 | 14 |
| 13 | SATYA KARTHIK R | 1KS22CS138 | 1 | 2 | 3 | 4 | 5 | 6 | 7 | 8 | 9 | 10 | 11 | 12 | 13 | 14 | 15 |
| 14 | SHAMANTH SREEPAD JOSHI | 1KS22CS139 | 1 | 2 | 3 | 4 | 5 | 6 | 7 | 8 | 9 | 10 | 11 | 12 | 13 | 14 | 15 |
| 15 | SHARANUBASAVA ARADHYA | 1KS22CS140 | 1 | 2 | 3 | 4 | 5 | 6 | A | A | A | 7 | 8 | 9 | 10 | 11 | 12 |
| 16 | SHASHANK H Y | 1KS22CS141 | 1 | 2 | 3 | 4 | 5 | 6 | 7 | 8 | 9 | 10 | 11 | 12 | 13 | 14 | 15 |
| 17 | SHASHANKGOUDA G GALI | 1KS22CS142 | A | 1 | 2 | 3 | 4 | A | 5 | 6 | 7 | 8 | 9 | A | 10 | 11 | 12 |
| 18 | SHRAVYA CS | 1KS22CS143 | 1 | 2 | 3 | 4 | 5 | 6 | 7 | 8 | 9 | 10 | 11 | 12 | 13 | 14 | 15 |
| 19 | SHRAVYA R | 1KS22CS144 | 1 | 2 | 3 | 4 | 5 | 6 | 7 | 8 | 9 | 10 | 11 | 12 | 13 | 14 | 15 |
| 20 | SHREEHARI D R | 1KS22CS145 | 1 | 2 | 3 | 4 | 5 | 6 | A | A | A | 7 | 8 | 9 | 10 | 11 | 12 |
| 21 | SHREYA MURTHY | 1KS22CS146 | 1 | 2 | 3 | 4 | 5 | 6 | 7 | 8 | 9 | 10 | 11 | 12 | 13 | 14 | 15 |
| 22 | SHREYA P.R | 1KS22CS147 | 1 | 2 | 3 | 4 | 5 | 6 | 7 | 8 | 9 | 10 | 11 | 12 | 13 | 14 | 15 |
| 23 | SINCHANA M | 1KS22CS149 | 1 | 2 | 3 | 4 | 5 | 6 | 7 | 8 | 9 | 10 | 11 | 12 | 13 | 14 | 15 |
| 24 | SINDHU | 1KS22CS150 | 1 | 2 | 3 | 4 | 5 | 6 | 7 | 8 | 9 | 10 | 11 | 12 | A | A | A |
| 25 | SIRI S GOWDA | 1KS22CS151 | 1 | 2 | 3 | 4 | 5 | 6 | A | 7 | 8 | 9 | 10 | 11 | A | A | A |
| 26 | SOURAV G | 1KS22CS152 | 1 | 2 | 3 | 4 | 5 | 6 | 7 | 8 | 9 | 10 | 11 | 12 | 13 | 14 | 15 |
| 27 | SRINIVAS KOUNDINYA T.D | 1KS22CS153 | A | 1 | 2 | 3 | 4 | 5 | 6 | 7 | 8 | 9 | 10 | 11 | 12 | 13 | 14 |

09:05 am
11:30 am
2:15 pm

K S INSTITUTE OF TECHNOLOGY

DEPARTMENT OF TRAINING AND PLACEMENTS

CONSOLIDATED ATTENDANCE FOR SOFT SKILL TRAINING

| 1 YEAR -CSD | | | 2nd SEMESTER | | | | | | SEC-D BATCH 7(NB-202) | | | | | | | | |
|-------------|---------------------|------------|--------------|---|---|------------|---|---|------------------------|---|---|------------|----|----|------------|----|----|
| SL. No | NAME OF THE STUDENT | USN | Dates | | | | | | | | | | | | | | |
| | | | 03/08/23 | | | 04/08/2023 | | | 05/08/2023 | | | 07/08/2023 | | | 08/08/2023 | | |
| | | | 1 | 2 | 3 | 4 | 5 | 6 | 7 | 8 | 9 | 10 | 11 | 12 | 13 | 14 | 15 |
| 1 | ADITHYA P | 1KS22CG001 | 1 | 2 | 3 | 4 | 5 | 6 | 7 | 8 | 9 | 10 | 11 | 12 | 13 | 14 | 15 |
| 2 | AJAY H M | 1KS22CG002 | 1 | 2 | 3 | 4 | 5 | 6 | 7 | 8 | 9 | 10 | 11 | 12 | 13 | 14 | 15 |
| 3 | AMITA S | 1KS22CG003 | 1 | 2 | 3 | 4 | 5 | 6 | 7 | 8 | 9 | 10 | 11 | 12 | 13 | 14 | 15 |
| 4 | P ANUDEEP | 1KS22CG004 | 1 | 2 | 3 | 4 | 5 | 6 | 7 | 8 | 9 | 10 | 11 | 12 | 13 | 14 | 15 |
| 5 | ANUSHA P R | 1KS22CG005 | 1 | 2 | 3 | 4 | 5 | 6 | 7 | 8 | 9 | 10 | 11 | 12 | 13 | 14 | 15 |
| 6 | BHARATH C | 1KS22CG006 | A | 1 | A | A | A | A | A | A | A | 2 | A | 3 | 4 | 5 | 6 |
| 7 | CHAITRA P | 1KS22CG007 | 1 | 2 | 3 | 4 | 5 | 6 | 7 | 8 | 9 | 10 | 11 | 12 | 13 | 14 | 15 |
| 8 | CHARAN B | 1KS22CG008 | A | 1 | 2 | 3 | 4 | 5 | 6 | 7 | 8 | 9 | A | A | 10 | 11 | 12 |
| 9 | CHARVITA RAO PAVAR | 1KS22CG009 | 1 | 2 | 3 | 4 | 5 | 6 | 7 | 8 | 9 | 10 | 11 | 12 | 13 | 14 | 15 |
| 10 | CHIRAG K | 1KS22CG010 | 1 | 2 | 3 | 4 | 5 | 6 | 7 | 8 | 9 | 10 | 11 | 12 | 13 | 14 | 15 |
| 11 | DAYANIDHI S | 1KS22CG011 | 1 | 2 | 3 | 4 | 5 | 6 | 7 | 8 | 9 | 10 | 11 | 12 | 13 | 14 | 15 |
| 12 | DEEKSHA C | 1KS22CG012 | 1 | 2 | 3 | 4 | 5 | 6 | A | A | A | 7 | 8 | 9 | 10 | 11 | 12 |
| 13 | DHANUSH S | 1KS22CG013 | 1 | 2 | 3 | 4 | 5 | 6 | 7 | 8 | 9 | 10 | 11 | 12 | 13 | 14 | 15 |
| 14 | E DURGAMAITRI | 1KS22CG014 | A | 1 | A | A | A | A | A | A | A | A | A | A | A | A | A |
| 15 | GOLLA SUKUMAR | 1KS22CG015 | A | 1 | A | A | A | A | A | A | A | A | A | A | A | A | A |
| 16 | HARSHITHA P | 1KS22CG016 | 1 | 2 | 3 | 4 | 5 | 6 | 7 | 8 | 9 | 10 | A | 11 | 12 | 13 | 14 |
| 17 | HEMANTH C H | 1KS22CG017 | A | 1 | A | A | A | A | A | A | A | A | A | A | A | A | A |
| 18 | HIMANSHU SHARMA | 1KS22CG018 | 1 | 2 | 3 | 4 | 5 | 6 | 7 | 8 | A | 9 | 10 | A | 11 | 12 | 13 |
| 19 | HRUSHIKESH R | 1KS22CG019 | 1 | 2 | 3 | 4 | 5 | 6 | 7 | 8 | 9 | 10 | 11 | 12 | 13 | 14 | 15 |
| 20 | JEEVIKA SREE K | 1KS22CG020 | A | 1 | A | 2 | 3 | 4 | 5 | 6 | 7 | A | A | A | 8 | 9 | 10 |
| 21 | JNANASHREE T R | 1KS22CG021 | 1 | 2 | 3 | 4 | 5 | 6 | 7 | 8 | 9 | 10 | 11 | 12 | 13 | 14 | 15 |
| 22 | K JAHNAVI CHOWDARY | 1KS22CG022 | 1 | 2 | 3 | 4 | 5 | 6 | 7 | 8 | A | A | A | A | 9 | 10 | 11 |

| | | | | | | | | | | | | | | | | | |
|----|---------------------------------|------------|---|---|---|---|---|---|---|---|---|----|----|----|----|----|----|
| 23 | KUSHAL GOWDA S R | 1KS22CG023 | A | 1 | A | A | A | A | A | A | A | 2 | 3 | 4 | A | A | 5 |
| 24 | LIKHITH M S | 1KS22CG024 | 1 | 2 | 3 | 4 | 5 | 6 | 7 | 8 | 9 | 10 | 11 | 12 | A | 13 | 14 |
| 25 | MADHUSRI P M | 1KS22CG025 | 1 | 2 | 3 | 4 | 5 | 6 | 7 | 8 | 9 | 10 | 11 | 12 | 13 | 14 | 15 |
| 26 | MAHARSHI S | 1KS22CG026 | 1 | 2 | 3 | 4 | 5 | 6 | 7 | 8 | 9 | 10 | 11 | 12 | 13 | 14 | 15 |
| 27 | MAHMOOD ZAYAAN KHAN NIZAM | 1KS22CG027 | 1 | 2 | 3 | 4 | 5 | 6 | A | A | A | 7 | 8 | 9 | 10 | 11 | 12 |
| 28 | MANASA R | 1KS22CG028 | 1 | 2 | 3 | 4 | 5 | 6 | 7 | 8 | 9 | 10 | 11 | 12 | 13 | 14 | 15 |
| 29 | MANAVI B M | 1KS22CG029 | 1 | 2 | 3 | 4 | 5 | 6 | 7 | 8 | 9 | 10 | 11 | 12 | 13 | 14 | 15 |
| 30 | MANOJ K | 1KS22CG030 | 1 | 2 | 3 | 4 | 5 | 6 | 7 | 8 | 9 | 10 | A | 11 | 12 | 13 | 14 |
| 31 | MANOJ S | 1KS22CG031 | 1 | 2 | 3 | 4 | 5 | 6 | 7 | 8 | 9 | 10 | 11 | 12 | 13 | 14 | 15 |
| 32 | MUHAMMAD KAIF A DODDAMANI | 1KS22CG032 | 1 | 2 | 3 | 4 | 5 | 6 | 7 | 8 | 9 | 10 | 11 | 12 | 13 | 14 | 15 |
| 33 | N GOVINDA PRASAD | 1KS22CG033 | 1 | 2 | 3 | 4 | A | 5 | 6 | 7 | 8 | 9 | 10 | 11 | 12 | 13 | 14 |
| 34 | INWESH KUMAR SINGH | 1KS22CG034 | 1 | 2 | 3 | 4 | 5 | 6 | 7 | 8 | A | 9 | 10 | A | 11 | 12 | 13 |
| 35 | P T ARCHISHA | 1KS22CG035 | 1 | 2 | 3 | 4 | 5 | 6 | 7 | 8 | 9 | 10 | 11 | 12 | 13 | 14 | 15 |
| 36 | PRAJVITH P | 1KS22CG036 | 1 | 2 | A | 3 | A | 4 | 5 | 6 | 7 | 8 | 9 | 10 | A | A | A |
| 37 | PRAJWAL R | 1KS22CG037 | 1 | 2 | 3 | 4 | 5 | 6 | 7 | 8 | 9 | 10 | 11 | 12 | 13 | 14 | 15 |
| 38 | PRANATHI M G | 1KS22CG038 | 1 | 2 | 3 | 4 | 5 | 6 | 7 | 8 | 9 | 10 | 11 | 12 | 13 | 14 | 15 |
| 39 | RAHUL P TRIVEDI | 1KS22CG039 | 1 | 2 | 3 | 4 | 5 | 6 | 7 | 8 | 9 | 10 | 11 | 12 | 13 | 14 | 15 |
| 40 | S SANIYA | 1KS22CG040 | 1 | 2 | 3 | 4 | 5 | 6 | 7 | 8 | 9 | 10 | 11 | 12 | 13 | 14 | 15 |
| 41 | SAAKSHI V JATTI | 1KS22CG041 | 1 | 2 | 3 | 4 | 5 | 6 | 7 | 8 | 9 | 10 | 11 | 12 | 13 | 14 | 15 |
| 42 | SAI KIRAN K | 1KS22CG042 | 1 | 2 | 3 | 4 | 5 | 6 | 7 | 8 | 9 | 10 | 11 | 12 | 13 | 14 | 15 |
| 43 | SHASHANK M | 1KS22CG043 | 1 | 2 | 3 | 4 | 5 | 6 | 7 | 8 | 9 | 10 | 11 | 12 | 13 | 14 | 15 |
| 44 | SHISHIR S DHEEP | 1KS22CG044 | 1 | 2 | 3 | 4 | 5 | 6 | 7 | 8 | 9 | 10 | 11 | 12 | 13 | 14 | 15 |
| 45 | SHRAVANI B G | 1KS22CG045 | 1 | 2 | 3 | 4 | 5 | 6 | 7 | 8 | 9 | 10 | 11 | 12 | 13 | 14 | 15 |
| 46 | SHREE LAKSHMI M | 1KS22CG046 | A | A | A | A | A | A | 1 | 2 | 3 | A | A | A | A | A | A |
| 47 | SHRISHA JOSHI | 1KS22CG047 | 1 | 2 | 3 | 4 | 5 | 6 | 7 | 8 | 9 | 10 | 11 | 12 | 13 | 14 | 15 |
| 48 | SPOORTHI S | 1KS22CG048 | 1 | 2 | 3 | 4 | 5 | 6 | 7 | 8 | 9 | 10 | 11 | 12 | 13 | 14 | 15 |
| 49 | SRINIDHI N | 1KS22CG049 | 1 | 2 | 3 | 4 | 5 | 6 | 7 | 8 | 9 | 10 | 11 | 12 | 13 | 14 | 15 |
| 50 | SRINIDHI R Y | 1KS22CG050 | 1 | 2 | 3 | 4 | 5 | 6 | 7 | 8 | 9 | A | A | A | 10 | 11 | 12 |

K S INSTITUTE OF TECHNOLOGY

DEPARTMENT OF TRAINING AND PLACEMENTS

CONSOLIDATED ATTENDANCE FOR SOFT SKILL TRAINING

| I YEAR -AIML | | 2nd SEMESTER | | | | | | SECTION-E BATCH 6(NB-203) | | | | | | | | | | | |
|--------------|---------------------|--------------|----------|---|---|------------|---|----------------------------|------------|---|---|------------|----|----|------------|----|----|---|---|
| SL. No | NAME OF THE STUDENT | USN | Dates | | | | | | | | | | | | | | | | |
| | | | 03/08/23 | | | 04/08/2023 | | | 05/08/2023 | | | 07/08/2023 | | | 08/08/2023 | | | | |
| | | | 1 | 2 | 3 | 4 | 5 | 6 | 7 | 8 | 9 | 10 | 11 | 12 | 13 | 14 | 15 | | |
| 1 | ABHINAV S BHAT | 1KS22AI001 | A | A | A | A | A | A | A | A | A | A | A | A | A | A | A | A | A |
| 2 | ADITI B PURANIK | 1KS22AI002 | 1 | 2 | 3 | 4 | 5 | 6 | 7 | 8 | 9 | 10 | 11 | 12 | 13 | 14 | 15 | | |
| 3 | AFRA FURKHEEN | 1KS22AI003 | 1 | 2 | 3 | 4 | 5 | 6 | 7 | 8 | 9 | 10 | 11 | 12 | 13 | 14 | 15 | | |
| 4 | AKASH Y | 1KS22AI004 | 1 | 2 | 3 | 4 | 5 | 6 | 7 | 8 | 9 | 10 | 11 | 12 | 13 | 14 | 15 | | |
| 5 | ANAMIKA | 1KS22AI005 | 1 | 2 | 3 | 4 | 5 | 6 | 7 | 8 | 9 | 10 | 11 | 12 | 13 | 14 | 15 | | |
| 6 | ANUSH R | 1KS22AI006 | 1 | 2 | 3 | 4 | 5 | 6 | 7 | 8 | 9 | 10 | 11 | 12 | 13 | 14 | 15 | | |
| 7 | ANVITHA S BADIGER | 1KS22AI007 | 1 | 2 | 3 | 4 | 5 | 6 | 7 | 8 | 9 | 10 | 11 | 12 | 13 | 14 | 15 | | |
| 8 | ARUN SAGAR GOWD | 1KS22AI008 | 1 | 2 | 3 | 4 | 5 | 6 | 7 | 8 | 9 | 10 | 11 | 12 | 13 | 14 | 15 | | |
| 9 | AYESHA TASMIYA | 1KS22AI009 | 1 | 2 | 3 | 4 | 5 | 6 | A | 7 | 8 | 9 | 10 | 11 | 12 | 13 | 14 | | |
| 11 | BHOOMIKA K | 1KS22AI010 | 1 | 2 | 3 | 4 | 5 | 6 | 7 | 8 | 9 | 10 | 11 | 12 | 13 | 14 | 15 | | |
| 10 | BHUVAN ADITYA M | 1KS22AI011 | 1 | 2 | 3 | 4 | 5 | 6 | 7 | 8 | 9 | 10 | 11 | 12 | 13 | 14 | 15 | | |
| 12 | CHANDANA V | 1KS22AI012 | 1 | 2 | 3 | 4 | 5 | 6 | 7 | 8 | 9 | 10 | 11 | 12 | 13 | 14 | 15 | | |
| 13 | D LIKITHA RAJU | 1KS22AI013 | 1 | 2 | 3 | 4 | 5 | 6 | 7 | 8 | 9 | 10 | 11 | 12 | 13 | 14 | 15 | | |
| 14 | DHANUSH C | 1KS22AI014 | 1 | 2 | 3 | 4 | 5 | 6 | 7 | 8 | 9 | 10 | 11 | 12 | 13 | 14 | 15 | | |
| 15 | GANASHREE K N | 1KS22AI015 | 1 | 2 | 3 | 4 | 5 | 6 | A | A | A | 7 | 8 | 9 | 10 | 11 | 12 | | |
| 16 | GIRISH B H | 1KS22AI016 | 1 | 2 | 3 | 4 | 5 | 6 | 7 | 8 | 9 | 10 | 11 | 12 | 13 | 14 | 15 | | |
| 17 | HARSHA C R | 1KS22AI017 | 1 | 2 | 3 | 4 | 5 | 6 | 7 | 8 | A | 9 | 10 | 11 | 12 | 13 | 14 | | |
| 18 | HAYAVADAN MADH | 1KS22AI018 | 1 | 2 | 3 | A | 5 | 6 | 7 | 8 | 9 | 10 | 11 | 12 | 13 | 14 | 15 | | |
| 19 | HRISHIKESH GANGA | 1KS22AI019 | 1 | 2 | 3 | 4 | 5 | 6 | 7 | 8 | 9 | 10 | 11 | 12 | 13 | 14 | 15 | | |
| 20 | HRISHIKESH JAYAKU | 1KS22AI020 | A | 1 | 2 | 3 | A | A | A | A | A | 4 | 5 | 6 | 7 | 8 | 9 | | |
| 21 | J N SANDEEP | 1KS22AI021 | 1 | 2 | 3 | A | A | A | 4 | 5 | 6 | 7 | 8 | 9 | 10 | 11 | 12 | | |
| 22 | KANDALA JAYANTH | 1KS22AI022 | A | 1 | 2 | 3 | 5 | 6 | 7 | 8 | 9 | 10 | 11 | 12 | 13 | 14 | 15 | | |
| 23 | KEERTHANA Y N | 1KS22AI023 | 1 | 2 | 3 | 4 | 5 | 6 | A | A | A | A | A | A | A | A | A | | |
| 24 | M VAISHNAVI | 1KS22AI024 | 1 | 2 | 3 | 4 | 5 | 6 | 7 | 8 | 9 | 10 | 11 | 12 | 13 | 14 | 15 | | |
| 25 | MANOJ HP | 1KS22AI025 | 1 | 2 | 3 | 4 | 5 | 6 | 7 | 8 | 9 | 10 | 11 | 12 | 13 | 14 | 15 | | |
| 26 | MAYUR D YADAV | 1KS22AI026 | 1 | 2 | 3 | 4 | 5 | 6 | 7 | 8 | 9 | 10 | 11 | 12 | 13 | 14 | 15 | | |
| 27 | MUYEEZ AHMED SH | 1KS22AI027 | 1 | 2 | 3 | 4 | 5 | 6 | 7 | 8 | 9 | 10 | 11 | 12 | 13 | 14 | 15 | | |

| | | | | | | | | | | | | | | | | | |
|----|-------------------|------------|--------------|--------------|--------------|--------------|--------------|---|---|---|---|----|----|----|----|----|----|
| 28 | NANDIGAM SRAVITHA | 1KS22AI028 | 1 | 2 | 3 | 4 | 5 | 6 | 7 | 8 | 9 | 10 | 11 | 12 | 13 | 14 | 15 |
| 29 | PALLAVI G | 1KS22AI029 | 1 | 2 | 3 | 4 | 5 | 6 | 7 | 8 | 9 | 10 | 11 | 12 | 13 | 14 | 15 |
| 30 | PAVAN S | 1KS22AI030 | 1 | 2 | 3 | 4 | 5 | 6 | 7 | 8 | 9 | 10 | 11 | 12 | 13 | 14 | 15 |
| 31 | PRADYUMNA VINAY | 1KS22AI031 | 1 | 2 | 3 | 4 | 5 | 6 | 7 | 8 | 9 | 10 | 11 | 12 | 13 | 14 | 15 |
| 32 | PRANATHI S HOLLA | 1KS22AI032 | 1 | 2 | 3 | 4 | 5 | 6 | 7 | 8 | 9 | 10 | 11 | 12 | 13 | 14 | 15 |
| 33 | PRASHANTH T | 1KS22AI033 | 1 | 2 | 3 | 4 | 5 | 6 | 7 | 8 | 9 | 10 | 11 | 12 | 13 | 14 | 15 |
| 34 | RAKSHITHA K | 1KS22AI034 | 1 | 2 | 3 | 4 | 5 | 6 | 7 | 8 | 9 | 10 | 11 | 12 | 13 | 14 | 15 |
| 35 | RANJITHA S | 1KS22AI035 | 1 | 2 | 3 | 4 | 5 | 6 | 7 | 8 | 9 | 10 | 11 | 12 | 13 | 14 | 15 |
| 36 | REVANTH N MITHRA | 1KS22AI036 | 1 | 2 | 3 | 4 | 5 | 6 | 7 | 8 | 9 | 10 | 11 | 12 | 13 | 14 | 15 |
| 37 | ROSHAN P J | 1KS22AI037 | 1 | 2 | 3 | 4 | 5 | 6 | 7 | 8 | 9 | 10 | 11 | 12 | 13 | 14 | 15 |
| 38 | S KARUNA | 1KS22AI038 | 1 | 2 | 3 | 4 | 5 | 6 | 7 | 8 | 9 | 10 | 11 | 12 | 13 | 14 | 15 |
| 39 | SAGAR A SHETTY | 1KS22AI039 | 1 | 2 | 3 | 4 | 5 | 6 | 7 | 8 | 9 | 10 | 11 | 12 | 13 | 14 | 15 |
| 40 | SAHITYA PRABHU | 1KS22AI040 | 1 | 2 | 3 | 4 | 5 | 6 | 7 | 8 | 9 | 10 | 11 | 12 | 13 | 14 | 15 |
| 41 | SAI TEJA NEKKANTI | 1KS22AI041 | 1 | 2 | 3 | 4 | 5 | 6 | 7 | 8 | 9 | 10 | 11 | 12 | 13 | 14 | 15 |
| 42 | SAMARTH R HEGDE | 1KS22AI042 | 1 | 2 | 3 | 4 | 5 | 6 | 7 | 8 | 9 | 10 | 11 | 12 | 13 | 14 | 15 |
| 43 | SANJAY B | 1KS22AI043 | 1 | 2 | 3 | 4 | 5 | 6 | 7 | 8 | 9 | 10 | 11 | 12 | 13 | 14 | 15 |
| 44 | SANNIDHI JOSHI | 1KS22AI044 | 1 | 2 | 3 | 4 | 5 | 6 | 7 | 8 | 9 | 10 | 11 | 12 | 13 | 14 | 15 |
| 45 | SHARATH M | 1KS22AI045 | 1 | 2 | 3 | 4 | 5 | 6 | 7 | 8 | 9 | 10 | 11 | 12 | 13 | 14 | 15 |
| 46 | SHASHANK S A | 1KS22AI046 | 1 | 2 | 3 | 4 | 5 | 6 | 7 | 8 | 9 | 10 | 11 | 12 | 13 | 14 | 15 |
| 47 | SHERWIN J | 1KS22AI047 | 1 | 2 | 3 | 4 | 5 | 6 | 7 | 8 | 9 | 10 | 11 | 12 | 13 | 14 | 15 |
| 48 | SHREEGANESH NAY | 1KS22AI048 | 1 | 2 | 3 | 4 | 5 | 6 | 7 | 8 | 9 | 10 | 11 | 12 | 13 | 14 | 15 |
| 49 | SHREYA S JAIN | 1KS22AI049 | 1 | 2 | 3 | 4 | 5 | 6 | 7 | 8 | 9 | 10 | 11 | 12 | 13 | 14 | 15 |
| 50 | SHREYAA G | 1KS22AI050 | 1 | 2 | 3 | 4 | 5 | 6 | 7 | 8 | 9 | 10 | 11 | 12 | 13 | 14 | 15 |
| 51 | SHWETABH SINGH | 1KS22AI051 | 1 | 2 | 3 | 4 | 5 | 6 | 7 | 8 | 9 | 10 | 11 | 12 | 13 | 14 | 15 |
| 52 | SIRI GOWRI R | 1KS22AI052 | 1 | 2 | 3 | 4 | 5 | 6 | 7 | 8 | 9 | 10 | 11 | 12 | 13 | 14 | 15 |
| 53 | SOUDAMINI H S | 1KS22AI053 | 1 | 2 | 3 | 4 | 5 | 6 | 7 | 8 | 9 | 10 | 11 | 12 | 13 | 14 | 15 |
| 54 | SRUSHTITHA S | 1KS22AI054 | 1 | 2 | 3 | 4 | 5 | 6 | 7 | 8 | 9 | 10 | 11 | 12 | 13 | 14 | 15 |
| 55 | THEJHASHVIN N | 1KS22AI055 | 1 | 2 | 3 | 4 | 5 | 6 | 7 | 8 | 9 | 10 | 11 | 12 | 13 | 14 | 15 |
| 56 | THOUSIF J | 1KS22AI056 | 1 | 2 | 3 | 4 | 5 | 6 | 7 | 8 | 9 | 10 | 11 | 12 | 13 | 14 | 15 |
| 57 | VAISHAK N NAIK | 1KS22AI057 | 1 | 2 | 3 | 4 | 5 | 6 | 7 | 8 | 9 | 10 | 11 | 12 | 13 | 14 | 15 |
| 58 | VANISHA M | 1KS22AI058 | 1 | 2 | 3 | 4 | 5 | 6 | 7 | 8 | 9 | 10 | 11 | 12 | 13 | 14 | 15 |
| 59 | VARSHINI B S | 1KS22AI059 | 1 | 2 | 3 | 4 | 5 | 6 | 7 | 8 | 9 | 10 | 11 | 12 | 13 | 14 | 15 |
| 60 | VARUN RAJ | 1KS22AI060 | 1 | 2 | 3 | 4 | 5 | 6 | 7 | 8 | 9 | 10 | 11 | 12 | 13 | 14 | 15 |
| 61 | VISHAL B M | 1KS22AI061 | 1 | 2 | 3 | 4 | 5 | 6 | 7 | 8 | 9 | 10 | 11 | 12 | 13 | 14 | 15 |

Not
hall

9:00 am
11:30 am
2:15 pm

| K S INSTITUTE OF TECHNOLOGY | | | | | | | | | | | | | | | | | |
|---|-----------------------------|------------|--------------|---|---|------------|---|---|----------------------------|---|---|------------|----|----|------------|----|----|
| DEPARTMENT OF TRAINING AND PLACEMENTS | | | | | | | | | | | | | | | | | |
| CONSOLIDATED ATTENDANCE FOR SOFT SKILL TRAINING | | | | | | | | | | | | | | | | | |
| I YEAR -ECE-F | | | 2nd SEMESTER | | | | | | SECTION-F BATCH 4(NB-205) | | | | | | | | |
| S. No | NAME OF THE STUDENT | USN | Dates | | | | | | | | | | | | | | |
| | | | 03/08/23 | | | 04/08/2023 | | | 05/08/2023 | | | 07/08/2023 | | | 08/08/2023 | | |
| | | | 1 | 2 | 3 | 4 | 5 | 6 | 7 | 8 | 9 | 10 | 11 | 12 | 13 | 14 | 15 |
| 1 | ABINAY | 1KS22EC001 | A | A | A | A | A | A | A | A | A | A | A | A | A | A | |
| 2 | ADEEBA ISMATH | 1KS22EC002 | 1 | 2 | 3 | 4 | 5 | 6 | A | A | A | A | A | 7 | 8 | 9 | |
| 3 | ADITH PINNEPALLI | 1KS22EC003 | 1 | 2 | 3 | 4 | 5 | 6 | 7 | 8 | 9 | 10 | 11 | 12 | 13 | 14 | 15 |
| 4 | ADITHYA S | 1KS22EC004 | 1 | 2 | 3 | 4 | 5 | 6 | 7 | 8 | 9 | 10 | 11 | 12 | 13 | 14 | 15 |
| 5 | AJITH D | 1KS22EC005 | A | A | A | A | A | A | A | A | A | A | A | A | A | A | A |
| 6 | AKASH S | 1KS22EC006 | 1 | 2 | 3 | 4 | 5 | 6 | 7 | 8 | 9 | 10 | 11 | 12 | 13 | 14 | 15 |
| 7 | AMRUTHA P | 1KS22EC007 | A | A | A | 1 | 2 | 3 | 4 | 5 | 6 | 7 | 8 | 9 | 10 | 11 | 12 |
| 8 | AMULYA M N | 1KS22EC008 | 1 | 2 | 3 | 4 | 5 | 6 | 7 | 8 | 9 | 10 | 11 | 12 | 13 | 14 | 15 |
| 9 | ANAGHA K S | 1KS22EC009 | 1 | 2 | 3 | 4 | 5 | 6 | 7 | 8 | 9 | A | A | A | 10 | 11 | 12 |
| 10 | ANKIT PRAKASH | 1KS22EC010 | 1 | 2 | 3 | 4 | 5 | 6 | 7 | 8 | 9 | 10 | 11 | 12 | 13 | 14 | 15 |
| 11 | ANKITA BUDNI | 1KS22EC011 | 1 | 2 | 3 | 4 | 5 | 6 | 7 | 8 | 9 | 10 | 11 | 12 | 13 | 14 | 15 |
| 12 | ANUPRIYA T | 1KS22EC012 | 1 | 2 | 3 | 4 | 5 | 6 | 7 | 8 | 9 | 10 | 11 | 12 | 13 | 14 | 15 |
| 13 | ANUSHA MALIPATIL | 1KS22EC013 | 1 | 2 | 3 | 4 | 5 | 6 | 7 | 8 | 9 | 10 | 11 | 12 | 13 | 14 | 15 |
| 14 | ARCHANA M | 1KS22EC014 | 1 | 2 | 3 | A | A | A | 4 | 5 | 6 | 7 | 8 | 9 | 10 | 11 | 12 |
| 15 | ARCHANA N | 1KS22EC015 | 1 | 2 | 3 | 4 | 5 | 6 | 7 | 8 | 9 | 10 | 11 | 12 | 13 | 14 | 15 |
| 16 | ARCHANA S K | 1KS22EC016 | 1 | 2 | 3 | 4 | 5 | 6 | 7 | 8 | 9 | 10 | 11 | 12 | 13 | 14 | 15 |
| 17 | ASHOK | 1KS22EC017 | A | A | 1 | 2 | 3 | 4 | 5 | 6 | 7 | 8 | 9 | 10 | 11 | 12 | 13 |
| 18 | ASHWINI P | 1KS22EC018 | A | A | A | A | A | A | A | A | A | 1 | 2 | 3 | 4 | 5 | 6 |
| 19 | AVINASH | 1KS22EC019 | 1 | 2 | 3 | 4 | 5 | 6 | 7 | 8 | 9 | 10 | 11 | 12 | 13 | 14 | 15 |
| 20 | AYYAJI MADHAVAN | 1KS22EC020 | A | 1 | 2 | 3 | 4 | 5 | 6 | 7 | 8 | 9 | 10 | 11 | A | A | A |
| 21 | BHOOMIKA D | 1KS22EC021 | 1 | 2 | 3 | 4 | 5 | 6 | 7 | 8 | 9 | 10 | 11 | 12 | 13 | 14 | 15 |
| 22 | C RAHUL | 1KS22EC022 | 1 | 2 | 3 | 4 | 5 | 6 | 7 | 8 | 9 | 10 | 11 | 12 | 13 | 14 | 15 |
| 23 | CHERUKURU HARIKA | 1KS22EC023 | A | A | A | A | A | A | A | A | A | A | A | A | A | A | A |
| 24 | CHETAN S P | 1KS22EC024 | A | A | 1 | 2 | 3 | 4 | 5 | A | A | 6 | 7 | 8 | 9 | 10 | 11 |
| 25 | CHETHAN A G | 1KS22EC025 | 1 | 2 | 3 | 4 | 5 | 6 | 7 | 8 | 9 | 10 | 11 | 12 | 13 | 14 | 15 |
| 26 | CHIDAMBAR PRABHAKAR CHINMAY | 1KS22EC026 | 1 | 2 | A | 3 | 4 | 5 | A | A | A | 6 | 7 | 8 | 9 | 10 | 11 |
| 27 | CHINMAY SHEELVANT | 1KS22EC027 | 1 | 2 | 3 | 4 | 5 | 6 | 7 | 8 | 9 | 10 | 11 | 12 | 13 | 14 | 15 |
| 28 | D N MITHUN | 1KS22EC028 | 1 | 2 | 3 | 4 | 5 | 6 | 7 | 8 | 9 | 10 | 11 | 12 | 13 | 14 | 15 |
| 29 | DARAPANENI ARUN CHOWDARY | 1KS22EC029 | 1 | 2 | 3 | 4 | 5 | 6 | 7 | 8 | 9 | A | 10 | 11 | A | 12 | 13 |
| 30 | DARSHAN GOWDA M K | 1KS22EC030 | 1 | 2 | 3 | 4 | 5 | 6 | 7 | 8 | 9 | A | A | A | 10 | 11 | 12 |
| 31 | DEEKSHA S REDDY | 1KS22EC031 | 1 | 2 | 3 | 4 | 5 | 6 | 7 | 8 | 9 | 10 | 11 | 12 | 13 | 14 | 15 |

| | | | | | | | | | | | | | | | | | |
|--|-----------------------|------------|--------------------------|----|----|----|----|----|----|----|----|----|----|----|----|----|----|
| 32 | DEEKSHA T S | 1KS22EC032 | 1 | 2 | 3 | 4 | 5 | 6 | 7 | 8 | 9 | 10 | 11 | 12 | 13 | 14 | 15 |
| 33 | DINESH N | 1KS22EC033 | AA | 1 | AA | AA | AA | 2 | 3 | 4 | 5 | 6 | 7 | 8 | 9 | 10 | |
| 34 | GAGAN V S | 1KS22EC034 | 1 | 2 | 3 | 4 | 5 | 6 | 7 | 8 | 9 | 10 | 11 | 12 | 13 | 14 | 15 |
| 35 | GAGANA S | 1KS22EC035 | 1 | 2 | 3 | 4 | 5 | 6 | AA | AA | AA | 7 | 8 | 9 | 10 | 11 | 12 |
| 36 | GAYATHRI DEVI B | 1KS22EC036 | 1 | 2 | 3 | 4 | 5 | 6 | 7 | 8 | 9 | 10 | 11 | 12 | 13 | 14 | 15 |
| 37 | GEHENA B S | 1KS22EC037 | 1 | 2 | 3 | 4 | 5 | 6 | 7 | 8 | 9 | 10 | 11 | 12 | 13 | 14 | 15 |
| 38 | GONUGUNTLA DEEPA SREE | 1KS22EC038 | AA | AA | 1 | 2 | 3 | 4 | 5 | 6 | 7 | AA | AA | AA | 8 | 9 | 9 |
| 39 | GOWTHAM M | 1KS22EC039 | 1 | 2 | 3 | 4 | 5 | 6 | 7 | 8 | 9 | 10 | 11 | 12 | 13 | 14 | 15 |
| 40 | GUNTURU DEEKSHITHA | 1KS22EC040 | 1 | 2 | 3 | 4 | 5 | 6 | 7 | 8 | 9 | 10 | 11 | 12 | 13 | 14 | 15 |
| 41 | HARISH M V | 1KS22EC041 | 1 | 2 | 3 | 4 | 5 | 6 | 7 | 8 | 9 | 10 | 11 | 12 | 13 | 14 | 15 |
| 42 | HARSHAN M J | 1KS22EC042 | 1 | 2 | 3 | 4 | 5 | 6 | 7 | 8 | 9 | 10 | 11 | 12 | 13 | 14 | 15 |
| 43 | HITHA SM | 1KS22EC043 | 1 | 2 | 3 | 4 | 5 | 6 | 7 | 8 | 9 | 10 | 11 | 12 | 13 | 14 | 15 |
| 44 | INCHARA C | 1KS22EC044 | 1 | 2 | 3 | 4 | 5 | 6 | 7 | 8 | 9 | 10 | 11 | 12 | 13 | 14 | 15 |
| 45 | K VAMSHIKRISHNA | 1KS22EC045 | 1 | 2 | 3 | 4 | 5 | 6 | 7 | 8 | 9 | 10 | 11 | 12 | 13 | 14 | 15 |
| 46 | KANDRA AMARENDRA | 1KS22EC046 | AA | 1 | 2 | 3 | 4 | 5 | 6 | 7 | AA | 8 | 9 | 10 | 11 | 12 | 13 |
| 47 | KARTHIK D | 1KS22EC047 | 1 | 2 | 3 | 4 | 5 | 6 | 7 | 8 | 9 | 10 | 11 | 12 | 13 | 14 | 15 |
| 48 | KAVYA G | 1KS22EC048 | 1 | 2 | 3 | AA | AA | AA | 4 | 5 | 6 | 7 | 8 | 9 | 10 | 11 | 12 |
| 49 | KEERTHANA K | 1KS22EC049 | 1 | 2 | 3 | AA | AA | AA | 4 | 5 | 6 | 7 | 8 | 9 | 10 | 11 | 12 |
| 50 | KIRAN G | 1KS22EC050 | 1 | 2 | 3 | 4 | 5 | 6 | 7 | 8 | 9 | 10 | 11 | 12 | 13 | 14 | 15 |
| 51 | KISHAN V | 1KS22EC051 | 1 | 2 | 3 | 4 | 5 | 6 | 7 | 8 | 9 | 10 | 11 | 12 | 13 | 14 | 15 |
| 52 | LAKSHMI M | 1KS22EC052 | 1 | 2 | 3 | 4 | 5 | 6 | 7 | 8 | 9 | AA | 10 | 11 | 12 | 13 | 14 |
| 53 | LAKSHMI P | 1KS22EC053 | 1 | 2 | 3 | AA | AA | AA | 4 | 5 | 6 | 7 | 8 | 9 | 10 | 11 | 12 |
| 54 | LEKHANA B H | 1KS22EC054 | 1 | 2 | 3 | 4 | 5 | 6 | 7 | 8 | 9 | 10 | 11 | 12 | 13 | 14 | 15 |
| 55 | LOHITH YAADAV R | 1KS22EC055 | 1 | 2 | 3 | 4 | 5 | 6 | 7 | 8 | 9 | 10 | 11 | 12 | 13 | 14 | 15 |
| 56 | M JAYASURRYA | 1KS22EC056 | AA | AA | AA | 1 | 2 | 3 | AA | AA | AA | 4 | 5 | 6 | 7 | 8 | 9 |
| 57 | MADHAM PURUSHOTHAM | 1KS22EC057 | 1 | 2 | 3 | 4 | 5 | 6 | 7 | 8 | 9 | 10 | 11 | 12 | 13 | 14 | 15 |
| 58 | MADHU HAROMUCHADI | 1KS22EC058 | 1 | 2 | 3 | 4 | 5 | 6 | 7 | 8 | 9 | 10 | 11 | 12 | 13 | 14 | 15 |
| 59 | MALLEMPUTA SUSHMITHA | 1KS22EC059 | AA | AA | 1 | 2 | 3 | 4 | AA | AA | AA | AA | AA | 5 | 6 | 7 | |
| 60 | MALLIKARJUNA SWAMY N | 1KS22EC060 | 1 | 2 | 3 | 4 | 5 | 6 | AA | AA | AA | 7 | 8 | 9 | 10 | 11 | 12 |
| 61 | MANASA CHOWDARY | 1KS22EC061 | 1 | 2 | 3 | 4 | 5 | 6 | 7 | 8 | 9 | 10 | 11 | 12 | 13 | 14 | 15 |
| 62 | MANOJKUMAR N | 1KS22EC062 | 1 | 2 | 3 | 4 | 5 | 6 | 7 | 8 | AA | AA | AA | AA | AA | AA | AA |
| 63 | MEGHANA S R | 1KS22EC063 | 1 | 2 | 3 | 4 | 5 | 6 | 7 | 8 | 9 | 10 | 11 | 12 | 13 | 14 | 15 |
| NO OF STUDENTS ABSENT | | | 12 | 11 | 06 | 08 | 08 | 08 | 08 | 09 | 09 | 10 | 08 | 08 | 06 | 05 | 05 |
| NO OF STUDENTS PRESENT | | | 51 | 52 | 57 | 55 | 55 | 55 | 55 | 54 | 54 | 52 | 55 | 55 | 57 | 57 | 57 |
| SIGNATURE OF THE TRAINER/ CLASS TEACHER/ PLACEMENT COORDINATOR | | | [Handwritten signatures] | | | | | | | | | | | | | | |

K S INSTITUTE OF TECHNOLOGY

DEPARTMENT OF TRAINING AND PLACEMENTS

CONSOLIDATED ATTENDANCE FOR SOFT SKILL TRAINING

| I YEAR -IOT | | 2nd SEMESTER | | | | | | SECTION-H BATCH 8(NB-302) | | | | | | | | | |
|-------------|--------------------------|--------------|----------|---|---|------------|---|----------------------------|------------|---|---|------------|----|----|------------|----|----|
| S. No | NAME OF THE STUDENT | USN | Dates | | | | | | | | | | | | | | |
| | | | 03/08/23 | | | 04/08/2023 | | | 05/08/2023 | | | 07/08/2023 | | | 08/08/2023 | | |
| | | | 1 | 2 | 3 | 4 | 5 | 6 | 7 | 8 | 9 | 10 | 11 | 12 | 13 | 14 | 15 |
| 1 | A SHRIYA | 1KS22IC001 | 1 | 2 | 3 | 4 | 5 | 6 | 7 | 8 | 9 | 10 | 11 | 12 | 13 | 14 | 15 |
| 2 | AARADHANA R | 1KS22IC002 | 1 | 2 | 3 | 4 | 5 | 6 | 7 | 8 | 9 | 10 | 11 | 12 | 13 | 14 | 15 |
| 3 | ABHIRAM SAMARTHA T R | 1KS22IC003 | A | 1 | 2 | A | 3 | 4 | 5 | 6 | 7 | A | 8 | 9 | 10 | 11 | 12 |
| 4 | ANUSHA A S | 1KS22IC004 | 1 | 2 | A | 3 | 4 | 5 | 6 | 7 | 8 | 9 | 10 | 11 | 12 | 13 | 14 |
| 5 | ARNAV P | 1KS22IC005 | 1 | 2 | 3 | 4 | 5 | 6 | 7 | 8 | 9 | 10 | 11 | 12 | 13 | 14 | 15 |
| 6 | BHAVANA N | 1KS22IC006 | 1 | 2 | 3 | 4 | 5 | 6 | 7 | 8 | 9 | 10 | 11 | A | 12 | 13 | 14 |
| 7 | BHAVYA P | 1KS22IC007 | 1 | 2 | 3 | 4 | 5 | 6 | 7 | 8 | 9 | 10 | 11 | 12 | 13 | 14 | 15 |
| 8 | C LITHISH | 1KS22IC008 | A | A | A | 1 | 2 | 3 | 4 | 5 | A | A | 6 | 7 | 8 | A | A |
| 9 | D AKSHAY KUMAR | 1KS22IC009 | 1 | 2 | 3 | 4 | 5 | 6 | 7 | 8 | 9 | 10 | 11 | 12 | 13 | A | A |
| 10 | DABBARA ADITHYA | 1KS22IC010 | A | 1 | A | A | A | A | 2 | 3 | 4 | A | A | A | 5 | 6 | 7 |
| 11 | DARSHAN M | 1KS22IC011 | 1 | 2 | 3 | 4 | 5 | 6 | 7 | 8 | 9 | 10 | 11 | 12 | 13 | 14 | 15 |
| 12 | DEEKSHITHA S A | 1KS22IC012 | A | A | A | A | A | A | A | A | A | 1 | 2 | 3 | 4 | 5 | 6 |
| 13 | GAGANDEEP NAIDU | 1KS22IC013 | 1 | 2 | 3 | 4 | 5 | 6 | 7 | 8 | 9 | 10 | 11 | 12 | 13 | 14 | 15 |
| 14 | HOYSALA Y DEVANGA | 1KS22IC014 | 1 | 2 | A | 3 | 4 | 5 | 6 | 7 | 8 | 9 | 10 | 11 | 12 | 13 | 14 |
| 15 | HP DARSHAN URS | 1KS22IC015 | 1 | 2 | 3 | 4 | 5 | 6 | 7 | 8 | 9 | 10 | 11 | 12 | 13 | 14 | 15 |
| 16 | J YAGNESH ANUGA | 1KS22IC016 | 1 | 2 | 3 | 4 | 5 | 6 | 7 | 8 | 9 | 10 | 11 | 12 | 13 | A | A |
| 17 | JAHAVI C | 1KS22IC017 | 1 | 2 | 3 | 4 | 5 | 6 | A | A | A | 7 | 8 | 9 | 10 | 11 | 12 |
| 18 | JETTI GOUTHAM | 1KS22IC018 | A | A | A | 1 | 2 | 3 | 4 | 5 | 6 | A | 7 | 8 | 9 | A | A |
| 19 | K M ANIL KUMAR | 1KS22IC019 | 1 | 2 | 3 | 4 | 5 | 6 | 7 | 8 | 9 | 10 | 11 | 12 | 13 | 14 | 15 |
| 20 | KOUSHAL K NAYAK | 1KS22IC020 | 1 | 2 | 3 | 4 | 5 | 6 | 7 | 8 | 9 | 10 | 11 | 12 | 13 | 14 | 15 |
| 21 | L MANEESH | 1KS22IC021 | 1 | 2 | 3 | 4 | 5 | 6 | 7 | 8 | 9 | 10 | 11 | 12 | 13 | A | A |
| 22 | LEENA J | 1KS22IC022 | 1 | 2 | 3 | 4 | 5 | 6 | 7 | 8 | 9 | 10 | 11 | 12 | 13 | A | A |
| 23 | MAHIMA A | 1KS22IC023 | 1 | 2 | 3 | 4 | 5 | 6 | A | A | A | 7 | 8 | 9 | 10 | 11 | 12 |
| 24 | MOHITH K | 1KS22IC024 | A | A | A | A | A | A | A | A | A | A | A | A | A | A | A |
| 25 | MOUSHAMI D | 1KS22IC025 | 1 | 2 | 3 | 4 | 5 | 6 | 7 | 8 | 9 | 10 | 11 | 12 | 13 | 14 | 15 |
| 26 | NISHANTH R | 1KS22IC026 | 1 | 2 | 3 | 4 | 5 | 6 | 7 | 8 | 9 | 10 | 11 | 12 | 13 | 14 | 15 |
| 27 | NISHMITHA SHETTY B S | 1KS22IC027 | 1 | 2 | 3 | 4 | 5 | 6 | 7 | 8 | 9 | 10 | 11 | 12 | 13 | 14 | 15 |
| 28 | NITHYASHREE K S | 1KS22IC028 | 1 | 2 | 3 | A | A | A | A | A | A | 4 | 5 | A | 6 | A | A |
| 29 | P SHROUMITH SIMHA PALETI | 1KS22IC029 | 1 | 2 | 3 | 4 | 5 | 6 | 7 | 8 | 9 | 10 | 11 | 12 | 13 | 14 | 15 |
| 30 | THIMMARAJU | 1KS22IC030 | A | A | 1 | 2 | 3 | 4 | 5 | 6 | 7 | A | 8 | 9 | 10 | A | A |

| | | | | | | | | | | | | | | | | | |
|--|---------------------------|------------|--------------------|--------------------|--------------------|--------------------|--------------------|--------------------|--------------------|--------------------|--------------------|--------------------|--------------------|--------------------|--------------------|--------------------|--------------------|
| 31 | PATHAKAMURI SUDEEPTHI | 1KS22IC031 | 1 | 2 | 3 | 4 | 5 | 6 | 7 | 8 | 9 | 10 | 11 | 12 | 13 | 14 | 15 |
| 32 | PRANAMYA K L | 1KS22IC032 | 1 | 2 | 3 | 4 | 5 | 6 | 7 | 8 | 9 | 10 | 11 | 12 | 13 | 14 | 15 |
| 33 | PRANAV MUDGAL | 1KS22IC033 | 1 | 2 | 3 | 4 | 5 | 6 | 7 | 8 | 9 | 10 | 11 | 12 | 13 | 14 | 15 |
| 34 | PUNEETH S | 1KS22IC034 | A | A | A | 1 | 2 | 3 | 4 | 5 | 6 | A | A | A | 7 | 8 | 9 |
| 35 | JAGADISHWAR | 1KS22IC035 | A | A | A | 1 | 2 | 3 | A | A | A | A | A | A | A | A | A |
| 36 | RACHNA V | 1KS22IC036 | 1 | 2 | 3 | 4 | 5 | 6 | 7 | 8 | 9 | 10 | 11 | 12 | 13 | 14 | 15 |
| 37 | RAHUL C | 1KS22IC037 | 1 | 2 | 3 | 4 | 5 | 6 | 7 | 8 | 9 | 10 | 11 | 12 | 13 | 14 | 15 |
| 38 | RISHIKA SRI LOKESH | 1KS22IC038 | 1 | 2 | 3 | 4 | 5 | 6 | 7 | 8 | 9 | 10 | 11 | 12 | 13 | 14 | 15 |
| 39 | SAAKSHI S URS | 1KS22IC039 | 1 | 2 | 3 | 4 | 5 | 6 | 7 | A | A | 8 | 9 | 10 | 11 | 12 | 13 |
| 40 | SADIYA NOOR | 1KS22IC040 | 1 | 2 | 3 | 4 | 5 | 6 | 7 | 8 | 9 | 10 | 11 | 12 | 13 | 14 | 15 |
| 41 | SAI SANJAYA M | 1KS22IC041 | 1 | 2 | 3 | 4 | 5 | 6 | 7 | 8 | 9 | 10 | 11 | 12 | 13 | 14 | 15 |
| 42 | SANJANA S | 1KS22IC042 | 1 | 2 | 3 | 4 | 5 | 6 | 7 | A | A | 8 | 9 | 10 | 11 | A | A |
| 43 | SANSKRITI BAGHAV BELLARY | 1KS22IC043 | 1 | 2 | 3 | 4 | 5 | 6 | 7 | 8 | 9 | 10 | 11 | 12 | 13 | 14 | 15 |
| 44 | SRINIDHI | 1KS22IC044 | 1 | 2 | 3 | 4 | 5 | 6 | 7 | 8 | 9 | 10 | 11 | 12 | 13 | 14 | 15 |
| 45 | SHESHAGIRI | 1KS22IC045 | 1 | 2 | 3 | 4 | 5 | 6 | 7 | 8 | 9 | 10 | 11 | 12 | 13 | 14 | 15 |
| 46 | SHIVAKUMAR M | 1KS22IC046 | 1 | 2 | A | 3 | 4 | 5 | 6 | 7 | 8 | 9 | 10 | A | 11 | 12 | 13 |
| 47 | SHREYA R | 1KS22IC047 | 1 | 2 | 3 | 4 | 5 | 6 | 7 | 8 | 9 | 10 | 11 | 12 | 13 | A | A |
| 48 | SHREYAS M V | 1KS22IC048 | 1 | 2 | 3 | 4 | 5 | 6 | 7 | 8 | 9 | 10 | 11 | 12 | 13 | 14 | 15 |
| 49 | SHREYAS S KUII KARNI | 1KS22IC049 | 1 | 2 | 3 | 4 | 5 | 6 | 7 | 8 | 9 | 10 | 11 | 12 | 13 | 14 | 15 |
| 50 | SIVA HARSHITHA | 1KS22IC050 | 1 | 2 | 3 | 4 | 5 | 6 | 7 | 8 | 9 | 10 | 11 | 12 | 13 | A | A |
| 51 | SNEHA | 1KS22IC051 | A | A | A | 1 | 2 | 3 | 4 | 5 | 6 | 7 | 8 | 9 | 10 | 11 | 12 |
| 52 | SWAROOP S | 1KS22IC052 | 1 | 2 | A | A | A | A | A | A | A | 3 | 4 | 5 | 6 | A | A |
| 53 | SYED MUTEEB BAKSHI TANISH | 1KS22IC053 | A | A | A | A | A | A | A | A | A | A | A | 1 | 2 | 3 | |
| 54 | KAVERIAPPA P | 1KS22IC054 | 1 | 2 | 3 | A | 4 | 5 | 6 | 7 | 8 | 9 | 10 | 11 | 12 | 13 | 14 |
| 55 | TARUN G K | 1KS22IC055 | A | A | A | A | A | A | A | A | A | A | A | A | A | A | A |
| 56 | TEJAS GOWDA N | 1KS22IC056 | 1 | 2 | 3 | 4 | 5 | 6 | 7 | 8 | 9 | 10 | 11 | 12 | 13 | 14 | 15 |
| 57 | THANUSHREE S K | 1KS22IC057 | 1 | 2 | 3 | 4 | 5 | A | 6 | A | A | A | A | A | 7 | 8 | 9 |
| 58 | TUSHAR BHAT | 1KS22IC058 | 1 | 2 | 3 | 4 | 5 | 6 | 7 | 8 | 9 | 10 | 11 | 12 | 13 | 14 | 15 |
| 59 | VAISHNAVI A | 1KS22IC059 | 1 | 2 | 3 | 4 | 5 | 6 | 7 | 8 | 9 | 10 | 11 | 12 | 13 | 14 | 15 |
| 60 | VARSHA P | 1KS22IC060 | 1 | 2 | 3 | 4 | 5 | 6 | A | A | A | 7 | 8 | 9 | 10 | 11 | 12 |
| 61 | VARUN N PRAKASH | 1KS22IC061 | 1 | 2 | 3 | A | 4 | 5 | 6 | 7 | 8 | 9 | 10 | 11 | 12 | 13 | 14 |
| 62 | VEDA K | 1KS22IC062 | 1 | 2 | 3 | 4 | 5 | 6 | 7 | 8 | 9 | 10 | 11 | 12 | 13 | 14 | 15 |
| NO OF STUDENTS ABSENT | | | 12 | 9 | 14 | 10 | 07 | 08 | 07 | 13 | 14 | 11 | 07 | 10 | 08 | 14 | 14 |
| NO OF STUDENTS PRESENT | | | 50 | 53 | 48 | 52 | 55 | 54 | 53 | 49 | 48 | 51 | 55 | 52 | 59 | 48 | 48 |
| SIGNATURE OF THE TRAINER/ CLASS TEACHER/ PLACEMENT COORDINATOR | | | <i>[Signature]</i> | <i>[Signature]</i> | <i>[Signature]</i> | <i>[Signature]</i> | <i>[Signature]</i> | <i>[Signature]</i> | <i>[Signature]</i> | <i>[Signature]</i> | <i>[Signature]</i> | <i>[Signature]</i> | <i>[Signature]</i> | <i>[Signature]</i> | <i>[Signature]</i> | <i>[Signature]</i> | <i>[Signature]</i> |

A A A A A A A A A A A
 A A A A A A A A A A A
 A A A A A A A A A A A

K S INSTITUTE OF TECHNOLOGY

DEPARTMENT OF TRAINING AND PLACEMENTS

CONSOLIDATED ATTENDANCE FOR SOFT SKILL TRAINING

| 1 YEAR -CCE | | | 2nd SEMESTER | | | | | | SECTION-I | | | BATCH 9(CCE) | | | | | |
|-------------|-----------------------|------------|--------------|---|---|------------|---|---|------------|---|---|--------------|----|----|------------|----|----|
| S. No | NAME OF THE STUDENT | USN | Dates | | | | | | | | | | | | | | |
| | | | 03/08/23 | | | 04/08/2023 | | | 05/08/2023 | | | 07/08/2023 | | | 08/08/2023 | | |
| | | | 1 | 2 | 3 | 4 | 5 | 6 | 7 | 8 | 9 | 10 | 11 | 12 | 13 | 14 | 15 |
| 1 | ADITHYA ARUN SATHVIK | 1KS22CM001 | 1 | P | 3 | 4 | 5 | 6 | A | A | A | 7 | 8 | 9 | 10 | 11 | 12 |
| 2 | ANITHA P C | 1KS22CM002 | A | A | A | 1 | 2 | 3 | 4 | 5 | 6 | 7 | 8 | 9 | 10 | 11 | 12 |
| 3 | ANUSH S | 1KS22CM003 | A | A | A | 1 | 2 | 3 | 4 | 5 | 6 | 7 | 8 | 9 | 10 | 11 | 12 |
| 4 | ARSHIYA J | 1KS22CM005 | 1 | P | 3 | 4 | 5 | 6 | 7 | 8 | 9 | 10 | 11 | 12 | 13 | 14 | 15 |
| 5 | ARUN L JADAVA LAMANI | 1KS22CM006 | 1 | P | A | 3 | 4 | 5 | 6 | 7 | 8 | 9 | 10 | 11 | 12 | 13 | 14 |
| 6 | B S AISHWARYA | 1KS22CM007 | 1 | P | 3 | 4 | 5 | 6 | 7 | 8 | 9 | 10 | 11 | 12 | 13 | 14 | 15 |
| 7 | B S BRUNDHA | 1KS22CM008 | 1 | P | 3 | 4 | 5 | 6 | 7 | 8 | A | 9 | 10 | 11 | 12 | 13 | 14 |
| 8 | BASAPUR GOPAL KRISHNA | 1KS22CM009 | 1 | P | 3 | 4 | 5 | 6 | 7 | 8 | 9 | 10 | 11 | 12 | 13 | 14 | 15 |
| 9 | BASAVARAJ PATIL | 1KS22CM010 | 1 | A | A | A | A | A | A | A | A | A | A | A | A | A | A |
| 10 | BRINDA S | 1KS22CM011 | 1 | P | 3 | 4 | 5 | 6 | 7 | 8 | 9 | 10 | 11 | 12 | 13 | 14 | 15 |
| 11 | DEEKSHA H R | 1KS22CM012 | 1 | P | 3 | 4 | 5 | 6 | A | A | A | 7 | 8 | 9 | 10 | 11 | 12 |
| 12 | DEEKSHA S | 1KS22CM013 | 1 | P | 3 | 4 | 5 | 6 | 7 | 8 | 9 | 10 | 11 | 12 | 13 | 14 | 15 |
| 13 | DEEPIKA G | 1KS22CM014 | 1 | P | 3 | 4 | 5 | A | A | A | A | 6 | 7 | 8 | 9 | 10 | |
| 14 | DINESH SHARMA B | 1KS22CM015 | 1 | P | 3 | 4 | 5 | 6 | 7 | 8 | 9 | 10 | 11 | 12 | 13 | 14 | 15 |
| 15 | DISHA A | 1KS22CM016 | 1 | P | 3 | 4 | 5 | 6 | 7 | 8 | 9 | 10 | 11 | 12 | 13 | 14 | 15 |
| 16 | GANGOTHRI P | 1KS22CM017 | 1 | P | 3 | 4 | 5 | 6 | 7 | 8 | 9 | 10 | 11 | 12 | 13 | 14 | 15 |
| 17 | H R CHANDANA | 1KS22CM018 | 1 | P | 3 | 4 | 5 | 6 | 7 | 8 | 9 | 10 | 11 | 12 | A | A | A |
| 18 | HAJIRA ANWAR | 1KS22CM019 | 1 | P | 3 | 4 | 5 | 6 | 7 | 8 | 9 | 10 | 11 | 12 | 13 | 14 | 15 |
| 19 | HAMEED VAJIR TERDALI | 1KS22CM020 | 1 | A | A | A | A | A | A | A | A | A | A | A | A | A | A |
| 20 | HEMANTH B R | 1KS22CM021 | 1 | P | 3 | 4 | 5 | 6 | 7 | 8 | 9 | 10 | 11 | 12 | 13 | 14 | 15 |
| 21 | HEMANTH K E | 1KS22CM022 | 1 | P | 3 | 4 | 5 | 6 | A | 7 | 8 | 9 | 10 | 11 | 12 | 13 | 14 |
| 22 | K R SHREYA | 1KS22CM023 | 1 | P | 3 | 4 | 5 | 6 | 7 | 8 | 9 | A | A | A | 10 | 11 | 12 |
| 23 | KARTHIK R JOSHI | 1KS22CM024 | 1 | P | 3 | 4 | 5 | 6 | 7 | 8 | 9 | 10 | 11 | 12 | 13 | 14 | 15 |
| 24 | KIRAN D | 1KS22CM025 | 2 | P | A | 3 | 4 | 5 | 6 | 7 | 8 | 9 | 10 | 11 | 12 | 13 | 14 |

| | | | | | | | | | | | | | | | | | |
|----|------------------------|------------|---|---|---|---|---|---|---|---|---|----|----|----|----|----|----|
| 25 | KUNDANKUMAR S | 1KS22CM026 | 1 | P | 3 | 4 | 5 | 6 | 7 | 8 | 9 | 10 | 11 | 12 | 13 | 14 | 15 |
| 26 | MAHALAKSHMI D | 1KS22CM027 | A | A | A | 1 | A | A | A | A | A | A | A | A | A | 2 | 3 |
| 27 | MANJUNATH K | 1KS22CM028 | 1 | P | A | A | A | A | A | A | A | A | A | A | A | A | A |
| 28 | MOHAMMED FAHIM R | 1KS22CM030 | 1 | P | 3 | 4 | 5 | 6 | 7 | 8 | 9 | 10 | 11 | 12 | 13 | 14 | 15 |
| 29 | NARASIMHA M K | 1KS22CM031 | 1 | P | 3 | 4 | 5 | 6 | 7 | 8 | 9 | 10 | 11 | 12 | 13 | 14 | 15 |
| 30 | NEELANJALI C | 1KS22CM032 | A | A | A | 1 | 2 | 3 | A | A | A | 4 | 5 | 6 | A | 7 | 8 |
| 31 | NIMISHA S L | 1KS22CM033 | 1 | P | 3 | 4 | 5 | 6 | 7 | 8 | 9 | 10 | 11 | 12 | 13 | 14 | 15 |
| 32 | NISHAL R | 1KS22CM034 | 1 | P | 3 | 4 | 5 | 6 | 7 | 8 | 9 | 10 | 11 | 12 | 13 | 14 | 15 |
| 33 | NITHIYA V | 1KS22CM035 | 1 | P | 3 | 4 | 5 | 6 | 7 | 8 | 9 | 10 | 11 | 12 | 13 | 14 | 15 |
| 34 | PAVAN R | 1KS22CM036 | A | A | A | 2 | 3 | A | A | A | A | A | A | A | A | A | A |
| 35 | PAVAN UMESH KULKARNI | 1KS22CM037 | 1 | P | 3 | 4 | 5 | 6 | 7 | 8 | 9 | 10 | 11 | 12 | 13 | 14 | 15 |
| 36 | PRAJWAL M P | 1KS22CM038 | 1 | P | 3 | 4 | 5 | 6 | 7 | 8 | 9 | 10 | 11 | 12 | 13 | 14 | 15 |
| 37 | PRUTHVIRAJ N | 1KS22CM039 | A | P | A | 2 | 3 | A | A | A | A | A | A | A | A | A | A |
| 38 | PUNITH K M | 1KS22CM040 | 1 | P | 3 | 4 | 5 | A | 6 | 7 | 8 | 9 | 10 | 11 | A | 12 | 13 |
| 39 | RAKSHITH M | 1KS22CM041 | A | A | A | 1 | 2 | A | 3 | 4 | 5 | A | A | A | 6 | A | A |
| 40 | SAI SMRITI M | 1KS22CM042 | 1 | P | 3 | 4 | 5 | 6 | 7 | 8 | 9 | 10 | 11 | 12 | 13 | 14 | 15 |
| 41 | SAKSHI SINGH | 1KS22CM043 | 1 | P | 3 | 4 | 5 | 6 | 7 | 8 | 9 | 10 | 11 | 12 | 13 | 14 | 15 |
| 42 | SATHVIK R P | 1KS22CM044 | 1 | P | 3 | 4 | 5 | 6 | 7 | 8 | 9 | 10 | 11 | 12 | 13 | 14 | 15 |
| 43 | SHREEDHANYA M S | 1KS22CM045 | 1 | P | 3 | 4 | 5 | 6 | 7 | 8 | 9 | 10 | 11 | 12 | 13 | 14 | 15 |
| 44 | SHREEPADA C | 1KS22CM046 | 1 | P | A | A | 3 | 4 | 5 | 6 | 7 | 8 | 9 | 10 | A | A | A |
| 45 | SHREYAS P | 1KS22CM047 | 1 | P | 3 | 4 | 5 | 6 | 7 | 8 | 9 | 10 | 11 | 12 | 13 | 14 | 15 |
| 46 | SHRIKUMAR | 1KS22CM048 | 1 | A | A | A | A | A | A | A | A | A | A | A | A | A | A |
| 47 | SNEHA B KORADAKERI | 1KS22CM049 | 1 | P | 3 | 4 | 5 | 6 | A | 7 | 8 | 9 | 10 | 11 | 12 | 13 | 14 |
| 48 | SREYASREE R JOSHI | 1KS22CM050 | 1 | P | 3 | 4 | 5 | 6 | 7 | 8 | 9 | 10 | 11 | 12 | 13 | 14 | 15 |
| 49 | SRILAKSHMI P Y | 1KS22CM051 | 1 | P | 3 | 4 | 5 | 6 | 7 | 8 | 9 | A | A | A | A | A | A |
| 50 | SRINIVASA R | 1KS22CM052 | 1 | P | 3 | A | 5 | 6 | 7 | 8 | 9 | 10 | 11 | 12 | 13 | 14 | 15 |
| 51 | SUHAS PRABHAKAR CHINDI | 1KS22CM053 | 1 | P | A | 3 | 4 | A | A | A | A | A | A | A | A | A | A |
| 52 | SUJAN S P | 1KS22CM054 | 1 | P | A | 3 | 4 | 5 | 6 | 7 | 8 | A | 9 | A | A | A | A |
| 53 | SUJITH MANNE | 1KS22CM055 | 1 | P | A | 3 | 4 | A | A | A | A | A | A | A | A | A | A |
| 54 | SURABHI RAO | 1KS22CM056 | 1 | P | 3 | 4 | 5 | 6 | 7 | 8 | 9 | 10 | 11 | 12 | 13 | 14 | 15 |
| 55 | UMME HANI | 1KS22CM057 | 1 | P | 3 | 4 | 5 | 6 | 7 | 8 | 9 | 10 | 11 | 12 | 13 | 14 | 15 |
| 56 | Y ISHITHA | 1KS22CM058 | 1 | P | 3 | 4 | 5 | 6 | 7 | 8 | 9 | 10 | 11 | 12 | 13 | 14 | 15 |

| | | | | | | | | | | | | | | | | | |
|---|--------------------------|------------|--------------|--------------|--------------|--------------|--------------|--------------|----|----|--------------|--------------|--------------|--------------|--------------|--------------|--------------|
| 57 | YERABOTHULA CHAITANYA | 1KS22CM059 | 1 | P | 3 | 4 | 5 | 6 | 7 | 8 | 9 | 10 | 11 | 12 | 13 | 14 | 15 |
| 58 | YERRABOTHULA KIRAN | 1KS22CM060 | A | A | A | A | A | A | 1 | 2 | A | A | A | A | A | A | A |
| NO OF STUDENTS ABSENT | | | 08 | P0 | 18 | 05 | 08 | 13 | 15 | 13 | 15 | 13 | 14 | 14 | 16 | 14 | 14 |
| NO OF STUDENTS PRESENT | | | 50 | 48 | 40 | 52 | 50 | 45 | 43 | 45 | 43 | 45 | 44 | 44 | 42 | 44 | 44 |
| SIGNATURE OF THE TRAINER/ CLASS TEACHER/ PLACEMENT COORDINATOR | | | | | | | | | | | | | | | | | |

T



**** DEPARTMENT OF TRAINING AND PLACEMENTS ****

Date: 25/07/2023

SOFT SKILLS TRAINING FOR 2nd SEMESTER STUDENTS – 2026 BATCH

Placement Department has planned to conduct Personality Development Training Program for 2nd Semester students starting from 03/08/2023 to 08/08/2023 from 8.50 AM to 03.50 PM. All HOD's are hereby requested to communicate their first-year students regarding the same.

The training will be conducted in Class rooms, NB. Batch wise details are shared below. All placement coordinators are requested to submit the consolidated **attendance of all 5 days** to Placement Department and to take the **feedback** for all the days. Department wise schedule is given below for your reference.

| Date | Time | Batch 1 | Batch 2 | Batch 3 | Batch 4 | Batch 5 | Batch6 | Batch7 | Batch 8 | Batch 9 |
|--|---------------------|-------------|---------|---------|---------|---------|--------|--------|---------|----------|
| | | CSE-A | CSE-B | CSE-C | ECE-A | ECE-B | AIML | CSD | IOT | CCE+MECH |
| 4 th , 5 th , 7 th and 8 th AUGUST 2023 | 8.50 AM - 11.00 AM | NB-101 | NB-102 | NB-104 | NB-205 | NB-301 | NB-203 | NB-202 | NB-302 | NB-304 |
| | 11.00 AM - 11.15 AM | Break | | | | | | | | |
| | 11.15AM - 1.15 PM | NB-101 | NB-102 | NB-104 | NB-205 | NB-301 | NB-203 | NB-202 | NB-302 | NB-304 |
| | 1.15 PM - 1.50 PM | Lunch Break | | | | | | | | |
| | 1.50 PM - 3.50 PM | NB-101 | NB-102 | NB-104 | NB-205 | NB-301 | NB-203 | NB-202 | NB-302 | NB-304 |

NOTE:

- All the students are informed to attend the session compulsorily in **Placement Dress code ONLY** (Solid White Shirt and Black trousers).
- Students are strictly informed to be present in their allocated rooms only for all the five days. **DO NOT SWAP THE BATCHES.**
- Feedback QR code will be displayed in all the training rooms. Students are informed to provide the feedback for each session before leaving the class.
- Certificates will be provided to those students having **100% attendance**

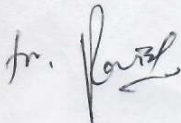

CC to HOD's and Coordinators of:

BS 

PRINCIPAL
PRINCIPAL
K.S. INSTITUTE OF TECHNOLOGY
BENGALURU - 560 109.



****DEPARTMENT OF TRAINING AND PLACEMENTS****

Date: 26/07/23

SOFT SKILLS TRAINING FOR 2ND AND 4TH SEMESTER STUDENTS

Dear all,

This is to inform you that Placement Department is conducting soft skills training for the 2nd and 4th semester students of KSIT, the students are required to attend the training sessions without fail.

If anybody is absent for any of the sessions, he/she is liable to pay a fine equivalent to the training cost.



Sharma. V
PRINCIPAL
PRINCIPAL
K.S. INSTITUTE OF TECHNOLOGY
BENGALURU - 560 109.

CC TO:

HODs and Coordinators of:

| | | | | | |
|----------------------------|---------------------------|---------------------------|---------------------------|----------------------------|------------------------------|
| AIML <i>[Signature]</i> | CSE <i>[Signature]</i> | CSD <i>[Signature]</i> | ECE <i>[Signature]</i> | MECH <i>[Signature]</i> | AS & H <i>[Signature]</i> |
|----------------------------|---------------------------|---------------------------|---------------------------|----------------------------|------------------------------|



K. S INSTITUTE OF TECHNOLOGY, BENGALURU-560109

14, Kanakapura Main Road, Raghuvanahalli, Bengaluru, Karnataka - 560109

4TH SEM CLASS TEACHERS

| SL NO | BRANCH&SECTION | CLASS TEACHERS NAME | DATE | SIGNATURE |
|-------|----------------|---------------------|----------|------------|
| 1 | CSE-A | Abhilesh L Bhat | 26/07/23 | Abhilesh |
| 2 | CSE-B | Namyapriya D | 27/07/23 | Namyapriya |
| 3 | ECE-A | Bhanumathi A | 26/7/23 | Bhanumathi |
| 4 | ECE-B | Anita P | 26/7/23 | Anita |
| 5 | AIML | LAKSHMI K K | 26/7/23 | Lakshmi |
| 6 | CSD | SUSHMA A | 26/7/23 | Sushma |
| 7 | MECH | HARISH U | 27/7/23 | Harish |

2ND SEM CLASS TEACHERS

| SL NO | BRANCH & SECTION | CLASS TEACHER NAME | DATE | SIGNATURE |
|-------|------------------|--------------------|------------|-----------|
| 1 | CSE-A | Radhika N.P | 26/7/23 | Radhika |
| 2 | CSE-B | Mamatha N | 26/7/23 | Mamatha |
| 3 | CSE-C | SHYLAJA KR | 26/07/23 | Shylaja |
| 4 | CSD-D | Dr. Harisha S | 27/07/23 | Harisha |
| 5 | AMIL-E | Lekshmi C | 26/7/23 | Lekshmi |
| 6 | ECE-F | Kanya T N | 26/7/23 | Kanya |
| 7 | ECE-G | Dr Renuka C | 26/7/23 | Renuka |
| 8 | IOT-H | Dr. Madhavi S | 26/07/2023 | Madhavi |
| 9 | CCE-I | Sneha G Kulkarni | 26/07/2023 | Sneha |
| 10 | MECH-J | TEJASWINI R | 26.07.23 | Tejaswini |



K S GROUP OF INSTITUTIONS
DEPARTMENT OF TRAINING AND PLACEMENTS
COMPARATIVE STATEMENT OF TRAINING VENDORS

| Name of Training Agency | Trainer Profile and Rating | | | | | Training Cost / Student / Hour |
|--|----------------------------|---|-------------------------|-------------------------------|--------------------|--|
| | 1 | 2 | 3 | 4 | 5 | |
| | Name | Qualification | Professional Experience | Specialization | Rating and Remarks | |
| AUDAZ | Asgar Pasha | B.Sc BBA HR | 18 years | Personality Development | 3+5=8 | AVG Score - $33/4 = 8.25$ (Offline) = 20.5/Student/Hr + GST |
| | Beliapa | B.E. M.Tech | 30 year | Soft Skills | 4+5=9 | |
| | Parvathi | B.A.M.A. MBA HR | 18 years | Personality Development | 3+5=8 | |
| | Kavitha M | B.Sc (Physics, Maths & Electronics) M.sc (Maths) | 20 years | Aptitude & Soft Skills | 3+5=8 | |
| Assessment Portal-Own portal available | | | | | 33 | |
| BIZOTIC | SRINATH SETHURAMAN | M.Sc, MBA (UK) | 20 Years | Soft Skills and Verbal | 3+5=8 | AVG Score - $33/4 = 8.25$ (Offline) = 20/Student/Hr + GST |
| | VINEET MANN | B.Sc, M.Sc | 15 Years | Aptitude | 3+5=8 | |
| | SHASHIKALA MADHUSUDHAN | LLB, M.Sc | 22 Years | Soft Skills and Verbal | 3+5=8 | |
| | K KRISHNA BAI | B.E, M.Tech (BSP) | 10 Years | Technical & Aptitude | 4+5=9 | |
| Assessment- Own Portal Available | | | | | 33 | |
| Quan Tech Origin | Deepak P.N | B.E, M.E | 08 Years | English and Soft skills | 3+4=7 | AVG Score - $25/4 = 6.25$ (Offline) = 20/Student/Hr + GST |
| | SAMUEL JOHN | Diploma (counselling skills), B.A | 12 Years | Communication and Soft Skills | 1+5=6 | |
| | Vignesh M.K. | B.E | 6 Years | Aptitude | 2+3=5 | |
| | Ananth P | B.E | 15 Years | Technical & Aptitude | 2+5=7 | |
| Assessment -Own Portal | | | | | | |

III Sem (KSIT+KSSE)

17 + 0.25

IV Sem (KSIT+KSSE)

20 + 0.25
K. Gurus
25/09/20

+



K S GROUP OF INSTITUTIONS
DEPARTMENT OF TRAINING AND PLACEMENTS
COMPARATIVE STATEMENT OF TRAINING VENDORS

| Name of Training Agency | Trainer Profile and Rating | | | | | Training Cost / Student / Hour |
|--|----------------------------|---|-------------------------|-------------------------|--------------------|--|
| | 1 | 2 | 3 | 4 | 5 | |
| | Name | Qualification | Professional Experience | Specialization | Rating and Remarks | |
| AUDAZ | Asgar Pasha | B.Sc MBA HR | 18 years | Personality Development | 3+5 = 8 | AVG Score - 33/4 = 8.25 ✓ (Offline) = 20.5/Student/Hr + GST |
| | Belliapa | B.E. M.Tech | 30 year | Soft Skills | 4+5 = 9 | |
| | Parvathi | B.A.M.A. MBA HR | 18 years | Personality Development | 3+5 = 8 | |
| | Kavitha M | B.Sc (Physics, Maths & Electronics) M.sc (Maths) | 20 years | Aptitude & Soft Skills | 3+5 = 8 | |
| Assessment Portal-Own portal available | | | | | 33 | |

The Same (KSIIT + KSGI)
17 + 0.25

| | | | | | | |
|-----------------------------------|------------------------|-------------------|----------|------------------------|---------|--|
| BIZOTIC | SRINATH SETHURAMAN | M.Sc, MBA (UK) | 20 Years | Soft Skills and Verbal | 3+5 = 8 | AVG Score - 33/4 = 8.25 ✓ (Offline) = 20/Student/Hr + GST |
| | VINEET MANN | B.Sc , M.Sc | 15 Years | Aptitude | 3+5 = 8 | |
| | SHASHIKALA MADHUSUDHAN | LLB, M.Sc | 22 Years | Soft Skills and Verbal | 3+5 = 8 | |
| | K KRISHNA BAI | B.E, M.Tech (BSP) | 10 Years | Technical & Aptitude | 4+5 = 9 | |
| Assessment - Own Portal Available | | | | | 33 | |

The Same (KSIIT + KSGI)
20 + 0.25
K. Ganesha
10/10/20

| | | | | | | |
|-----------------------------------|--------------|-----------------------------------|----------|-------------------------------|-----------|--|
| Quan Tech Origin | Deepak P.N | B.E, M.E | 08 Years | English and Soft skills | 3+4 = 7 | AVG Score - 25/4 = 6.25 ✓ (Offline) = 20/Student/Hr + GST |
| | SAMUEL JOHN | Diploma (counselling skills), B.A | 12 Years | Communication and Soft Skills | 1+5 = 6 | |
| | Vignesh M.K. | B.E | 6 Years | Aptitude | 2+3 = 5 | |
| | Ananth P | B.E | 15 Years | Technical & Aptitude | 2 + 5 = 7 | |
| Assessment - Own Portal Available | | | | | 25 | |

X

| | | | | | | |
|--------------------------------------|--------------|-----------------|----------|---------------------------|-------|---|
| Transit | Beema N | B.Sc. MS, PGDBA | 22 Years | Behavior skills, Aptitude | 4+5=9 | AVG Score - 28/4 = 7 (Offline) = 23/Student/Hr + GST |
| | Sowmya Kiran | B.E | 08 Years | Aptitude | 2+4=6 | |
| | AMIT MONDLE | | 20 Years | Personality Development | 2+3=5 | |
| | Arun Kumar | M.Sc, MBA | 17 Years | Technical & Aptitude | 3+5=8 | |
| Assessment - Skill Under Development | | | | | 28 | |

MBA (I & II year)
19+GST

| | | | | | | |
|--------------------------------------|-------------|--------------------------------------|----------|--|--------|--|
| Skill Factory | Raghavan | B.Com & MBA (HR) | 14 Years | Soft Skills and Verbal Skills | 3+5=8 | AVG Score - 33/4 = 8.25 (Offline) = 21/Student/Hr + GST |
| | Nisha | B.Com & MBA (Fin) | 10 Years | Logical, Analytical and Verbal | 3+5=8 | |
| | Dr. Jacob S | Ph.D | 14 Years | Placement oriented skills, verbal skills | 5+5=10 | |
| | Narasimha | B.E (Information Science) & MDA (MR) | 8 Years | Logical, Analytical and Verbal | 3+4=7 | |
| Assessment - Skill Under Development | | | | | 33 | |

(KSIIT + KSSeri)
VII Semester
20+case 18%
helps interw

| | | | | | | |
|--------------------------------------|----------------|-------------|----------|---------------------------------|-------|---|
| Universal Education | Avinhek Ghosh | B.Sc, MBA | 12 Years | Aptitude and Reasoning | 3+5=8 | AVG Score - 34/4 = 8.5 (Offline) = 22/Student/Hr + GST |
| | V Nandini Nair | B.Sc, MBA | 12 Years | Verbal and communication skills | 3+3=6 | |
| | Ahanshu Ghosh | B.E, MBA | 12 Years | Aptitude and Reasoning | 4+5=9 | |
| | Tapas Guha | B.E, M.Tech | 12 Years | Technical Trainer | 4+5=9 | |
| Assessment - Skill Under Development | | | | | 34 | |

| | | | | | | |
|--------------------------------------|-------------|---------------------|----------|---------------------------|-------|--|
| JV Global | Darshan B V | B.E, Mech | 6 Years | Quantitative & Analytical | 4+3=7 | AVG Score - 31/4 = 7.75 (Offline) = 25/Student/Hr + GST |
| | Bhargav A P | BA, MA | 10 Years | Soft skills | 4+4=8 | |
| | Beema N | B.Sc, PG, MS, PGDBA | 18 Years | Pre Placement Topics | 4+5=9 | |
| | Beema S | BE, Mech | 6 Years | Quantitative & Analytical | 4+3=7 | |
| Assessment - Skill Under Development | | | | | 31 | |

| | | | | | | |
|--------------------------------------|----------------|------------|----------|---------------------------------|-------|--|
| Pentagon Space | Yashwanth K N | BBM, MBA | 6 Years | Verbal and communication skills | 3+3=6 | AVG Score - 30/4 = 7.50 (Offline) = 32/Student/Hr + GST |
| | Hanu R | BE, M.Tech | 08 Years | Technical Trainer | 4+4=8 | |
| | DASHRATH MISAL | B.Com, MA | 15 Years | Soft skills and english | 3+5=8 | |
| | ARCHANA M S | B.Com, MBA | 13 Years | Soft skills | 3+5=8 | |
| Assessment - Skill Under Development | | | | | 30 | |

Call the above for negotiations.

Shubhal
06/10/22

6/10/22

TRANSIT

Training & Recruitment Partner

#324, 3rd Main road, 7th Cross road, Srinivasanagar, Bangalore-560 050
Mobile: +91 906 693 1423 | E-mail:ranjithnk04@gmail.com

Bill To:

K S Institute of Technology

No 14, Kanakapura Rd, Raghuvanahalli, Bangalore
City Municipal Corporation Layout, Bengaluru,
Karnataka 560109

Invoice No : TTRP001/23-24

Invoice Date: 14/08/2023

TAX INVOICE

| SI.NO | Product Description | No of students | Rate | Amount |
|--|--------------------------------------|----------------|--|----------|
| 1 | Soft skills Training- BE II Semester | 546 | 540 | 2,94,840 |
| Amount in words: Three Lakh Forty Seven Thousand Nine Hundred and Eleven Rupees Only | | | Total Amount | 2,94,840 |
| | | | GST 18% | 53,071 |
| | | | Net balance to pay | 3,47,911 |
| GST Number: 29EZCPR8344R1Z7 PAN Number :EZCPR8344R Bank details : TRANSIT- Training and Recruitment Partner Account No : 120002825715 IFSC Code: CNRB0000473 Please Make all checks payables to above mentioned details | | | For TRANSIT For TRANSIT Training And Recruitment Partner Ranjith NK (Proprietor) Authorized Signatory | |

THANK YOU!



R. Kumar
18/8/23

[Signature] 18/8/23
CHIEF EXECUTIVE OFFICER
Member Secretary
Academic Advisory Board
K.S. Group of Institutions

[Signature]
22/08/23



KSIT
K.S. INSTITUTE OF TECHNOLOGY

Kammavari Sangham (R) 1952
K.S. GROUP OF INSTITUTIONS

ಕೆ.ಎಸ್. ತಾಂತ್ರಿಕ ಮಹಾವಿದ್ಯಾಲಯ

K.S. INSTITUTE OF TECHNOLOGY

Accredited By NAAC

14, Raghuvanahalli, Kanakapura Road, Bengaluru - 560 109.

Tel : 080 28435722 / 24, Fax : 080 28435723

E-mail : principal.ksit@gmail.com / principal@ksit.edu.in | website : www.ksit.edu.in

Ref: KSIT/PO/2022-2023/TPO 007

Date: 02/08/2023

To,
TRANSIT
Training & Recruitment Partner
#3234, 3rd Main Road, 7th Cross Road, Srinivasanagar
Bangalore, Karnataka-560050

Dear Sir,

Sub: Purchase Order for Soft Skills Training Program for 1st year B.E Students.

With reference to the above, we are pleased to place the order for Soft Skills Training Program for 2nd Semester Students at K.S.Institute of Technology, #14, Raghuvanahalli, Kanakapura Road, Bangalore - 109 as per the following specifications, terms & conditions.

Programme Commercials:

| SL.No. | Description | Quantity | Rate | Amount |
|--------|--|----------|---|------------|
| 1 | Soft Skills Training Program for First Year B.E Students. | 546 | Rs. 18/Hour/Student (546 × 30Hrs × 18Rs) | 2,94,840/- |
| | Total | | | 2,94,840/- |
| | Taxable Value | | | |
| | ADD: (CGST 9% + SGST 9%) GST | | 18% | 53,071/- |
| | Grand TOTAL | | | 3,47,911/- |

Amount in Words: Rupees Three Lakhs Forty Seven Thousand Nine Hundred And Eleven Only.

Terms & Conditions:

- Training for 2nd Semester students would be from 3rd-8th July 2023.
- Full Payment to be made post satisfactory completion of the training.

Thanking you,

Hon. Secretary

KAMMAVARI SANGHAM

K.S. INSTITUTE OF TECHNOLOGY

Approved by AICTE , New Delhi & Affiliated to VTU, Belagavi, Karnataka



DEPARTMENT OF TRAINING AND PLACEMENTS

Soft Skills Training and Placements

Date of Conduction: 03-08-2023 to 08-08-2023

Venue: (NB) Class Rooms, KSIT

Time: 8.50 AM. TO 3.50 PM

Duration: 30 HOURS

Objective of the Training Program

The sole objective of imparting Soft skills training program is to enable students to learn critical evaluation techniques and various real life situations by resorting to analyze key issues. This training program will help students to enhance the problem solving skills, improve Communication skills, discover their interests and career choices, to maximize potentialities and boosting self-confidence, understanding high demand in society and have good job prospects and to help students prepare for competitive examinations and higher studies.

Soft Skills

Strong communication skills:- Improves the ability to speak professional English, building positive relationships with stakeholders, and showing inspiring leadership qualities – typically called “Soft Skills” – are becoming increasingly essential for degree and manufacturing professionals.

Many Degree professionals assume that their technical expertise and experience is the only thing that will get them a job. However, this is changing as engineers are increasingly expected to partner with the business, and these soft skills – when coupled with the right combination of technical skills – are in great demand, and can set them apart in a highly competitive jobs market. Soft skills are all those personal attributes that sit outside professional qualifications and work experience. They refer to how people interact, lead and communicate with other people, and they're an essential foundation for any successful career. There is no doubt about the fact that the technical skills are an absolute essential for an engineer to perform his job diligently and efficiently. The fact that the second skill set, that is, the soft skills along with the hard skills are an absolute essential for growth of an engineer in the organization. A blend of both is what determines their level of success as a professional. A soft skill is not just limited to the workplace of a professional but extends to other spheres of their life too for example social and family.

Soft skills is not just about communicating, but includes ability to manage stress, ability to organize, ability to provide solutions. Most of the times the importance of soft skills is ignored and not given adequate attention for engineers. The education that goes in to make an engineer does not concentrate on the people skills. The curriculum tends to ignore the fact that at the end of the day an engineer would be working in a team, reporting to someone, taking reports, dealing with work pressures, giving presentations, attending phone calls, sending mails just to specify a few. In all such situations along with technical skills, experience and physiological maturity of an individual is going to play an important role.



| | | Batch 01 | Batch 02 | Batch 03 | Batch 04 | Batch 05 | Batch 06 | Batch 07 | Batch 08 | Batch 09 |
|-----------------------|----|------------------------|------------------------|------------------------|------------------------|------------------------|------------------------|------------------------|------------------------|------------------------|
| | | CS A | CS B | CS C | CSD | AIML | EC A | EC B | 101 | CCE+ME |
| | | 101 | 102 | 104 | 202 | 203 | 205 | 301 | 302 | 304 |
| Thursday 03-Aug-23 | S1 | Sam | Vedavathi | Shiva | Jhanavi | Ashfak | Arun Sax | Srinath | Imran | Panchami |
| | | Work Culture | Adaptability | Stress Management | Conflict Resolution | Letter Email LinkedIn | Problem Solving | SWOT Analysis | Confidence Building | Active Listening |
| | S2 | Panchami | Sam | Vedavathi | Shiva | Jhanavi | Ashfak | Arun Sax | Srinath | Imran |
| | | Active Listening | Work Culture | Adaptability | Stress Management | Conflict resolution | Letter Email LinkedIn | Problem Solving | SWOT Analysis | Confidence Building |
| | S3 | Imran | Panchami | Sam | Vedavathi | Shiva | Jhanavi | Ashfak | Arun Sax | Srinath |
| | | Confidence Building | Active Listening | Work Culture | Adaptability | Stress Management | Conflict resolution | Letter Email LinkedIn | Problem Solving | SWOT Analysis |
| Friday 04-Aug-23 | S1 | Srinath | Imran | Panchami | Sam | Vedavathi | Shiva | Jhanavi | Ashfak | Arun Sax |
| | | SWOT Analysis | Confidence building | Active Listening | Work Culture | Adaptability | Stress Management | Conflict resolution | Letter Email LinkedIn | Problem Solving |
| | S2 | Arun Sax | Srinath | Imran | Panchami | Sam | Vedavathi | Shiva | Jhanavi | Ashfak |
| | | Problem solving | SWOT Analysis | Confidence building | Active Listening | Work Culture | Adaptability | Stress Management | Conflict resolution | Letter Email LinkedIn |
| | S3 | Ashfak | Arun Sax | Srinath | Imran | Panchami | Sam | Vedavathi | Shiva | Jhanavi |
| | | Letter Email LinkedIn | Problem Solving | SWOT Analysis | Confidence Building | Active Listening | Work Culture | Adaptability | Stress Management | Conflict Resolution |
| Saturday 05-Aug-23 | S1 | Jhanavi | Prem | Arun Sax | Srinath | Imran | Panchami | Ajay | Vedavathi | Shiva |
| | | Conflict resolution | Professionalism | Problem Solving | SWOT Analysis | Confidence building | Active Listening | Intrapersonal skills | Adaptability | Stress Management |
| | S2 | Shiva | Jhanavi | Prem | Arun Sax | Srinath | Imran | Panchami | Ajay | Vedavathi |
| | | Stress Management | Conflict resolution | Professionalism | Problem Solving | SWOT Analysis | Confidence building | Active Listening | Intrapersonal skills | Adaptability |
| | S3 | Vedavathi | Shiva | Jhanavi | Prem | Arun Sax | Srinath | Imran | Panchami | Ajay |
| | | Adaptability | Stress Management | Conflict resolution | Professionalism | Problem Solving | SWOT Analysis | Confidence building | Active Listening | Intrapersonal skills |
| Monday 07-Aug-23 | S1 | Ajay | Ashfak | Shiva | Jhanavi | Prem | Arun Sax | Srinath | Imran | Panchami |
| | | Intrapersonal skills | Letter Email LinkedIn | Communication skills 2 | Grooming | Professionalism | Decision Making | Emotional Intelligence | Grooming | Communication skills 2 |
| | S2 | Panchami | Ajay | Ashfak | Shiva | Jhanavi | Prem | Arun Sax | Srinath | Imran |
| | | Communication skills 2 | Intrapersonal skills | Letter Email LinkedIn | Communication skills 2 | Grooming | Professionalism | Decision Making | Emotional Intelligence | Grooming |
| | S3 | Imran | Panchami | Ajay | Ashfak | Shiva | Jhanavi | Prem | Arun Sax | Srinath |
| | | Grooming | Communication skills 2 | Intrapersonal skills | Letter Email LinkedIn | Communication skills 2 | Grooming | Professionalism | Decision Making | Emotional Intelligence |
| Tuesday 08-Aug-23 | S1 | Srinath | Imran | Panchami | Ajay | Vedavathi | Shiva | Sam | Prem | Arun Sax |
| | | Emotional Intelligence | Grooming | Decision Making | Intrapersonal skills | Emotional Intelligence | Communication skills 2 | Work Culture | Professionalism | Decision Making |
| | S2 | Arun Sax | Jhanavi | Imran | Panchami | Ajay | Vedavathi | Shiva | Sam | Prem |
| | | Decision Making | Emotional Intelligence | Grooming | Decision Making | Intrapersonal skills | Emotional Intelligence | Communication skills 2 | Work Culture | Professionalism |
| | S3 | Prem | Arun Sax | Srinath | Imran | Panchami | Ajay | Jhanavi | Shiva | Sam |
| | | Professionalism | Decision Making | Emotional Intelligence | Emotional Intelligence | Decision Making | Intrapersonal skills | Emotional Intelligence | Communication skills 2 | Work Culture |

Outcomes / Benefits:

Students are able to apply soft skills in multidisciplinary applications.

PO Mapping:

| PO | PO1 | PO2 | PO3 | PO4 | PO5 | PO6 | PO7 | PO8 | PO9 | PO10 | PO11 | PO12 |
|------------------------------------|-----|-----|-----|-----|-----|-----|-----|-----|-----|------|------|------|
| Soft skill training and Placements | | | | 2 | | | | | 3 | 3 | | 3 |

Shefaja K.R.
Coordinator



Principal
PRINCIPAL
K.S. INSTITUTE OF TECHNOLOGY
BENGALURU - 560 109.



AXIS BANK LTD

PHASE 6TH PHASE BANGLORE JK, BENGALURU, 560076
IFS CODE - UTIB0001013

A/c. PAYEE ONLY

VALID FOR THREE MONTHS FROM THE DATE OF ISSUE

DATE **08 11 20 22**
FORM D D M M Y Y Y Y

REVENUE/AM. QTR - 2018 - 23.07.2022 51.4287*

Pay **Audaz Ventures Pvt Ltd**

OR BEARER / या धारक को

रुपये Rupees **One lakh seventy six thousand
eight hundred seven only**

अदा करें ₹ **1,76,807/-**

A/C NO. **912010014093916**

For K S INSTITUTE OF TECHNOLOGY

FLTRS 000180



[Signature]
Authorized Signatory(ies)

Please sign above

Payable at par at all branches of Axis Bank Ltd in India.

⑈ 224436⑈ 560211034⑈ 000160⑈ 3⑈

*Received
Asst.
12/11/22*



K S GROUP OF INSTITUTIONS

DEPARTMENT OF TRAINING AND PLACEMENTS

COMPARATIVE STATEMENT OF TRAINING VENDORS

| Name of Training Agency | Trainer Profile and Rating | | | | | Training Cost / Student / Hour |
|---|----------------------------|--|------------------------------|-------------------------------|-------------------------|--|
| | 1 Name | 2 Qualification | 3 Professional Experience | 4 Specialization | 5 Rating and Remarks | |
| AUDAZ | Asgar Pasha | B.Sc B.A.M | 18 years | Personality Development | 3+5 = 8 | AVG Score - 33/4 = 8.25 (Offline) = 20/Student/Hr + GST |
| | Beethpa | B.E. M.Tech | 30 year | Soft Skills | 4+5 = 9 | |
| | Parvathi | B.A, M.A. MBA HR | 18 years | Personality Development | 3+5 = 8 | |
| | Kavitha M | B.Sc (Physics, streams in Electronics M.Sc (Maths) M.A. English | 20 years | Aptitude & Soft Skills | 3+5 = 8 | |
| Assessment - Partial-Own portal available | | | | | 33 | |
| BIZOTIC | SRI NATH SETHURAMAN | M.Sc, MBA (UK) | 20 Years | Soft Skills and Verbal | 3+5 = 8 | AVG Score - 33/4 = 8.25 (Offline) = 20/Student/Hr + GST |
| | VINEET MANN | B.Sc, M.Sc | 15 Years | Aptitude | 3+5 = 8 | |
| | SHASHIKALA MADHUSUDHAN | LLR, M.Sc | 22 Years | Soft Skills and Verbal | 3+5 = 8 | |
| | K. KRISHNA BAI | B.E, M.Tech (BSP) | 10 Years | Technical & Aptitude | 4+5 = 9 | |
| Assessment - Own Portal Available | | | | | 33 | |
| Quan Tech Origin | Deepak P.N | B.E, M.E | 08 Years | English and Soft-skills | 3+4 = 7 | AVG Score - 25/4 = 6.25 (Offline) = 20/Student/Hr + GST |
| | SAMUEL JOHN | Diploma (counselling skills), B.A | 12 Years | Communication and Soft Skills | 1+5 = 6 | |
| | Vignesh M.K. | B.E | 6 Years | Aptitude | 2+3 = 5 | |
| | Ananth P | B.E | 15 Years | Technical & Aptitude | 2 + 5 = 7 | |
| Assessment - Own Portal Available | | | | | 25 | |

III Sem (KSIIT, KSSE)

17 + 0.25

V Sem (KSIIT, KSSE)

20 + 0.25
K. Govind
15/10/20

+



KSIT
K.S. INSTITUTE OF TECHNOLOGY

Kammavari Sangham (R) 1952
K.S. GROUP OF INSTITUTIONS

ಕೆ.ಎಸ್. ತಾಂತ್ರಿಕ ಮಹಾವಿದ್ಯಾಲಯ

K.S. INSTITUTE OF TECHNOLOGY
Accredited By NAAC

14, Raghuvanahalli, Kanakapura Road, Bengaluru - 560 109.

Tel : 080 28435722 / 24, Fax : 080 28435723

E-mail : principal.ksit@gmail.com / principal@ksit.edu.in | website : www.ksit.edu.in

Ref: KSIT/PO/2022-2023/TPO 005

Date: 01/10/2022

To,
Audaz Ventures Private Ltd.
C-2-C-2/100, Janakpuri, South West Delhi - 110058

Dear Sir,

Sub: Purchase Order for Internship Program for 3rd Semester B.E Students.

With reference to the above, we are pleased to place the order for **Internship Program** for 3rd Semester Students at **K.S. Institute of Technology**, #14, Raghuvanahalli, Kanakapura Road, Bangalore – 109 as per the following specifications, terms & conditions.

Programme Commercials:

| Sl.No. | Description | Quantity | Rate | Amount |
|---|--|----------|---|----------------------|
| 1 | Internship Program for III Semester B.E Students | 321 | Rs. 17/Hour/Student (321 × 30Hrs × 17Rs) | 1,63,710/- |
| | Total | | | 1,63,710/- |
| | Taxable Value | | | 29,467.80/- |
| | ADD: CGST 9% | | | 14,733.9/- |
| | ADD: SGST 9% | | | 14,733.9/- |
| | Grand TOTAL | | | 1,93,178.35/- |
| Amount in Words: Rupees One Lakh Ninety Three Thousand One Hundred Seventy Eight Only | | | | |

Terms & Conditions:

- Internship dates for 3rd Semester students would be from 11th – 15th October 2022.
- Full Payment to be made post satisfactory completion of the training.

Thanking you,

07/11/22
Hon. Secretary

KAMMAVARI SANGHAM



K. S INSTITUTE OF TECHNOLOGY, BENGALURU

14, Kanakapura Main Road, Raghuvanahalli, Bengaluru, Karnataka - 560109

** DEPARTMENT OF TRAINING AND PLACEMENTS **

08.10.2022

INTERNSHIP PROGRAM FOR 3rd SEMESTER STUDENTS

Placement Department has planned to conduct **Mandatory Internship Program** suggested by VTU, for 3rd Semester students starting from 11/10/2022 to 15/10/2022 from 8.50 AM to 4.00 PM. HODs of respective departments are hereby requested to communicate their 3rd Semester students regarding the same.

The training will be conducted in old building Ground and First floor. Respective **Class Teachers** are **requested** to take the attendance in the first 15 minutes only in all the sessions and to submit the consolidated **attendance on all 5 days** to Placement Department. Batch wise schedule is given below for your reference.

| DATE | TIME | BATCH | BATCH | BATCH | BATCH | BATCH | BATCH |
|--|-------------------|-------------|--------|----------|----------|----------|----------|
| | | 1 | 2 | 3 | 4 | 5 | 6 |
| 11 th to 15 th October 2022 | 8.50AM -11.00AM | OB-007 | OB-008 | OB - 101 | OB - 203 | OB - 105 | OB - 106 |
| | 11.00AM - 11.15AM | BREAK | | | | | |
| | 11.15AM - 1.15PM | OB-007 | OB-008 | OB - 101 | OB - 203 | OB - 105 | OB - 106 |
| | 1.15PM - 1.50PM | LUNCH BREAK | | | | | |
| | 1.50PM - 4.00PM | OB-007 | OB-008 | OB - 101 | OB - 203 | OB - 105 | OB - 106 |

NOTE:

- Students are strictly informed to be present in their allocated rooms only for all the five days. **DO NOT SWAP THE BATCHES.**
- Feedback QR code will be displayed in all the training rooms. **Students are informed to provide the feedback for each session before leaving the class.**
- **Credits and Certificates will be given to those students who will have 95% attendance.**



K. S. Kumar
PRINCIPAL
PRINCIPAL
K.S. INSTITUTE OF TECHNOLOGY
BENGALURU - 560 109.

CC to:
HODs and Coordinators of:

| | | | | | |
|------------------------|------------------------|-----------------------|------------------------|-------------------------|---------------------------|
| CSE <i>[Signature]</i> | ECE <i>[Signature]</i> | ME <i>[Signature]</i> | CSD <i>[Signature]</i> | AIML <i>[Signature]</i> | BS & H <i>[Signature]</i> |
|------------------------|------------------------|-----------------------|------------------------|-------------------------|---------------------------|

K.S.INSTITUTE OF TECHNOLOGY

Department of Training and Placements

INTERNSHIP PROGRAM _3rd Semester

BATCH 1 -COMPUTER SCIENCE & ENGINEERING (OB-007)

| SL.NO | USN | NAME OF THE STUDENT |
|-------|------------|----------------------------|
| 1 | 1KS21CS001 | A RAMYASREE |
| 2 | 1KS21CS002 | AARYA M |
| 3 | 1KS21CS003 | ABHILASHA V |
| 4 | 1KS21CS004 | ABHIRAM K |
| 5 | 1KS21CS005 | ABHIRAM YADATORE SHANTARAM |
| 6 | 1KS21CS006 | ADITHI R |
| 7 | 1KS21CS007 | ADITHI S REDDY |
| 8 | 1KS21CS008 | ADITYA V |
| 9 | 1KS21CS009 | AFIFAH AYESHA BIJLI |
| 10 | 1KS21CS010 | AISHWARYA G |
| 11 | 1KS21CS011 | AKSHAY VIVEKANANDA B |
| 12 | 1KS21CS012 | ANANYA PRASAD S |
| 13 | 1KS21CS014 | ARCHANA P |
| 14 | 1KS21CS015 | ARTHAN M GOWDA |
| 15 | 1KS21CS016 | ASHA H P |
| 16 | 1KS21CS017 | ASHWINI |
| 17 | 1KS21CS018 | B G PRAJWAL |
| 18 | 1KS21CS020 | BHAVANA B |
| 19 | 1KS21CS021 | CHAITRA M |
| 20 | 1KS21CS022 | CHARISHMA A |
| 21 | 1KS21CS023 | CHARISHMA M |
| 22 | 1KS21CS024 | CHEZHAN H |
| 23 | 1KS21CS025 | DARSHAN S |
| 24 | 1KS21CS026 | DEEPTHI A B |
| 25 | 1KS21CS027 | DHRUTHI UMESH S |
| 26 | 1KS21CS028 | D L SHIVANG |
| 27 | 1KS21CS029 | GAANA S |
| 28 | 1KS21CS030 | GAGAN SHIVANNA |
| 29 | 1KS21CS031 | GOPALA KRISHNA V |
| 30 | 1KS21CS032 | GURUPRASAD Y S |
| 31 | 1KS21CS033 | HARSHITHA K M |
| 32 | 1KS21CS034 | HARSHITHA P |

| SL.NO | USN | NAME OF THE STUDENT |
|-------|------------|-----------------------|
| 33 | 1KS21CS035 | HARSHITHA R |
| 34 | 1KS21CS036 | HARSHITHA S |
| 35 | 1KS21CS037 | HARSHITHA S |
| 36 | 1KS21CS038 | HEMANTH KUMAR V |
| 37 | 1KS21CS039 | HRITHIKA V |
| 38 | 1KS21CS040 | IBBANI V GOWDA |
| 39 | 1KS21CS041 | IMAN GHORAI |
| 40 | 1KS21CS042 | JAHNAVI P |
| 41 | 1KS21CS043 | JASHWANTH P C |
| 42 | 1KS21CS044 | K MEGHANA |
| 43 | 1KS21CS045 | KANISHK E R |
| 44 | 1KS21CS046 | KARTHIK H N |
| 45 | 1KS21CS047 | KAUSHIK G V |
| 46 | 1KS21CS048 | KAVANA N |
| 47 | 1KS21CS049 | KAVYA B SINGH |
| 48 | 1KS21CS050 | KEERTHIKA S |
| 49 | 1KS21CS051 | KONGARA SREE SAI |
| 50 | 1KS21CS052 | KUNAPALLI LAASYASHRRE |
| 51 | 1KS21CS053 | L.LAVANYA |
| 52 | 1KS21CS054 | M VAIBHAV NAYAK |
| 53 | 1KS21CS055 | MADHU SNEHA SHREE S |
| 54 | 1KS21CS056 | MANIKANTH |
| 55 | 1KS21CS057 | MANJUNATH |
| 56 | 1KS21CS058 | MANOJ KUMAR S |
| 57 | 1KS21CS059 | MAUSAM KUMAR |
| 58 | 1KS21CS060 | MAYA |



(Signature)
PRINCIPAL
K.S. INSTITUTE OF TECHNOLOGY
BENGALURU - 560 109.

K.S.INSTITUTE OF TECHNOLOGY

Department of Training and Placements

INTERNSHIP PROGRAM _3rd Semester

BATCH 2 -COMPUTER SCIENCE & ENGINEERING (OB -008)

| SL.NO | USN | NAME OF THE STUDENT |
|-------|------------|--------------------------|
| 1 | 1KS21CS061 | MONIKA D |
| 2 | 1KS21CS062 | N VIDYASAGAR |
| 3 | 1KS21CS063 | NAGADARSHAN R P |
| 4 | 1KS21CS064 | NAGASHREE A |
| 5 | 1KS21CS065 | NAREN RAKSHITH K V |
| 6 | 1KS21CS066 | NETYAM SHIVSARAN |
| 7 | 1KS21CS067 | NIKHIL SAI K V |
| 8 | 1KS21CS068 | NOOR ZAHIDA |
| 9 | 1KS21CS069 | OMKAR ARJUN MAGADUM |
| 10 | 1KS21CS070 | POOJA G |
| 11 | 1KS21CS071 | POOJITHA M V |
| 12 | 1KS21CS072 | POOJITHA R |
| 13 | 1KS21CS073 | PRANAY G |
| 14 | 1KS21CS074 | PRIYANKA V |
| 15 | 1KS21CS075 | R AISHWARYA |
| 16 | 1KS21CS076 | R HARSHA |
| 17 | 1KS21CS077 | RAKSHITA G SATARADDI |
| 18 | 1KS21CS078 | RAKSHITHA D H |
| 19 | 1KS21CS079 | RASHMI B PHULARI |
| 20 | 1KS21CS080 | RAVEESH PRASAD M |
| 21 | 1KS21CS081 | RAVITEJ ARJUN KAKHANDAKI |
| 22 | 1KS21CS082 | REDDY TEJASWINI A |
| 23 | 1KS21CS083 | RUSHIKESH B |
| 24 | 1KS21CS084 | RUTHU M R |
| 25 | 1KS21CS085 | SAGAR S N |
| 26 | 1KS21CS086 | SAMRAT SINGH |
| 27 | 1KS21CS087 | SANTHOSH K A |
| 28 | 1KS21CS088 | SHAMITHA RAVISHANKAR |
| 29 | 1KS21CS089 | SHEETAL NAIK |
| 30 | 1KS21CS090 | SHEETHAL G |
| 31 | 1KS21CS091 | SHEETHAL R |
| 32 | 1KS21CS092 | SHOEB AHMED QUADRI |

| SL.NO | USN | NAME OF THE STUDENT |
|-------|------------|----------------------|
| 33 | 1KS21CS093 | SHREYAS C |
| 34 | 1KS21CS094 | SINDHU MEGHA |
| 35 | 1KS21CS095 | SKANDA KUMAR H S |
| 36 | 1KS21CS096 | SNEHA S |
| 37 | 1KS21CS097 | SOUJANYA N |
| 38 | 1KS21CS098 | SRINIDHI MADHUSUDHAN |
| 39 | 1KS21CS099 | SUMAN B S |
| 40 | 1KS21CS100 | SUMEDHA R |
| 41 | 1KS21CS101 | SUMUKHA S BHARADWAJ |
| 42 | 1KS21CS102 | SUNIDHI P |
| 43 | 1KS21CS103 | SURESH C |
| 44 | 1KS21CS104 | SUSHMITHA M |
| 45 | 1KS21CS105 | SWAROOP S KOWSHIK |
| 46 | 1KS21CS106 | TEJASHREE GOWDA Y K |
| 47 | 1KS21CS107 | UJWAL M L |
| 48 | 1KS21CS108 | V M TEJUS |
| 49 | 1KS21CS109 | VAISHALI BHOSLE |
| 50 | 1KS21CS110 | VANISHREE |
| 51 | 1KS21CS111 | VARSHA H R |
| 52 | 1KS21CS112 | VARUN SAI V |
| 53 | 1KS21CS113 | VIBHA GOVIN S |
| 54 | 1KS21CS114 | VIJETHA S |
| 55 | 1KS21CS115 | VILAS V |
| 56 | 1KS21CS116 | VISHAL KAMAN |
| 57 | 1KS21CS117 | YASHAS D GOWDA |
| 58 | 1KS21CS118 | YASHASHWINI R |

Principals
 PRINCIPAL
 K.S. INSTITUTE OF TECHNOLOGY
 BENGALURU - 560 109.



K.S.INSTITUTE OF TECHNOLOGY

Department of Training and Placements

INTERNSHIP PROGRAM _3rd Semester

BATCH 3 -ELECTRONICS AND COMMUNICATION ENG (OB -101)

| SL.NO | USN | NAME OF THE STUDENT |
|-------|------------|---------------------|
| 1 | 1KS21EC001 | AADHYA B N |
| 2 | 1KS21EC002 | ABHIJITH R |
| 3 | 1KS21EC003 | ABHISHEK H C |
| 4 | 1KS21EC004 | ABHISHEK T S |
| 5 | 1KS21EC005 | AISHWARYA A |
| 6 | 1KS21EC006 | AKSHAY C |
| 7 | 1KS21EC007 | AKSHAY M S |
| 8 | 1KS21EC008 | ANAGHA PRAKASH |
| 9 | 1KS21EC009 | ANIRUDHA R BHAT |
| 10 | 1KS21EC010 | ARCHANA G M |
| 11 | 1KS21EC011 | ARCHANA M |
| 12 | 1KS21EC012 | ARJUN BHARADWAJ |
| 13 | 1KS21EC013 | ASHCHARYA N B |
| 14 | 1KS21EC014 | ASHWIN S R |
| 15 | 1KS21EC015 | B N JEEVAN |
| 16 | 1KS21EC016 | B P SAMARTH |
| 17 | 1KS21EC017 | B S BHARGAV |
| 18 | 1KS21EC018 | BHAVYA K |
| 19 | 1KS21EC019 | BHUVANA H |
| 20 | 1KS21EC020 | BINDUSHREE S |
| 21 | 1KS21EC021 | CHINTAN D S |
| 22 | 1KS21EC022 | CHIRAG S |
| 23 | 1KS21EC023 | CHIRANTH V V |
| 24 | 1KS21EC024 | DAGGUPATI CHARITHA |
| 25 | 1KS21EC025 | DAMINI S |
| 26 | 1KS21EC026 | DEEKSHA H K |
| 27 | 1KS21EC027 | DEEPIKA D |
| 28 | 1KS21EC028 | GAGAN V |
| 29 | 1KS21EC029 | GAGANA SINDHU N |
| 30 | 1KS21EC030 | GREESHMA S |
| 31 | 1KS21EC031 | GURUSHANKARA M |
| 32 | 1KS21EC032 | HARINI.L |
| 33 | 1KS21EC033 | HEMANTH D R |
| 34 | 1KS21EC035 | KAMBHAMPATI VIVEK |

| SL.NO | USN | NAME OF THE STUDENT |
|-------|------------|-----------------------|
| 35 | 1KS21EC036 | KARAN S |
| 36 | 1KS21EC037 | KEERTHANA S |
| 37 | 1KS21EC038 | KOMALA N |
| 38 | 1KS21EC039 | KUSHAL GOWDA U |
| 39 | 1KS21EC040 | KUSUMA M S |
| 40 | 1KS21EC041 | LIKITHA L |
| 41 | 1KS21EC042 | LOHIT HOOLAGERI |
| 42 | 1KS21EC043 | LOHITH B |
| 43 | 1KS21EC044 | LOHITH S |
| 44 | 1KS21EC045 | MANOJ T V |
| 45 | 1KS21EC046 | MEGHANA N |
| 46 | 1KS21EC047 | MISBA M |
| 47 | 1KS21EC048 | MITHUN C |
| 48 | 1KS21EC049 | MONISHA D |
| 49 | 1KS21EC050 | MUTTHULURU SAI HIMAJA |
| 50 | 1KS21EC051 | NANDAN K |
| 51 | 1KS21EC052 | NANDAN P B |
| 52 | 1KS21EC053 | NARAHARI N JOSHI |
| 53 | 1KS21EC054 | NAVEEN S |
| 54 | 1KS21EC055 | NAYANA J |
| 55 | 1KS21EC056 | NAYANA S |
| 56 | 1KS21EC057 | NIDHI R |
| 57 | 1KS21EC058 | OMKAR N BHUJARKAR |
| 58 | 1KS21EC059 | PAVAN M PAI |
| 59 | 1KS21EC060 | POLURU MANJUNATH |



D. Kumar. S.
 PRINCIPAL
 K.S. INSTITUTE OF TECHNOLOGY
 BENGALURU - 560 109.

K.S.INSTITUTE OF TECHNOLOGY

Department of Training and Placements

INTERNSHIP PROGRAM _3rd Semester

BATCH 4 -ELECTRONICS AND COMMUNICATION ENG (OB -104)

| SL.NO | USN | NAME OF THE STUDENT |
|-------|------------|---------------------------|
| 1 | 1KS21EC061 | POOJA R |
| 2 | 1KS21EC062 | PRAJWAL D |
| 3 | 1KS21EC063 | PRAJWAL G V |
| 4 | 1KS21EC064 | PRAJWAL H S |
| 5 | 1KS21EC065 | PRAJWAL R |
| 6 | 1KS21EC066 | PRATHAM R SHANBHAG |
| 7 | 1KS21EC067 | PRAYAG SINGH S |
| 8 | 1KS21EC068 | PREETHAM M |
| 9 | 1KS21EC069 | PREKSHA S |
| 10 | 1KS21EC070 | PUNITH M |
| 11 | 1KS21EC071 | RAGHAVENDRA NARAYAN PUJAR |
| 12 | 1KS21EC072 | RAKSHITH S |
| 13 | 1KS21EC073 | RAKSHITHA M R |
| 14 | 1KS21EC074 | RAYADURG JOISH SHRIYA |
| 15 | 1KS21EC075 | REHAMAN SHARIFF |
| 16 | 1KS21EC076 | RITESH KUMAR SINHA |
| 17 | 1KS21EC077 | RITHIKA M |
| 18 | 1KS21EC078 | S HARI DHANUSH |
| 19 | 1KS21EC080 | S. SHAJITH ALI |
| 20 | 1KS21EC081 | SAGAR G S |
| 21 | 1KS21EC082 | SAI RAHUL N |
| 22 | 1KS21EC083 | SAMHITHA PRAKASH |
| 23 | 1KS21EC084 | SANJANA V |
| 24 | 1KS21EC085 | SANJAY G |
| 25 | 1KS21EC086 | SANJAY N |
| 26 | 1KS21EC087 | SANJAY P |
| 27 | 1KS21EC088 | SATHYAM KUMAR MANDAL S |
| 28 | 1KS21EC089 | SHAIK ARFATH |
| 29 | 1KS21EC090 | SHASHANK C U |
| 30 | 1KS21EC091 | SHREYAS RAGHAVENDRA V |
| 31 | 1KS21EC092 | SHWETHA V |
| 32 | 1KS21EC093 | SINDHU M NIMBAL |
| 33 | 1KS21EC095 | SPOORTHY M U |
| 34 | 1KS21EC096 | SRILAKSHMI G |

| SL.NO | USN | NAME OF THE STUDENT |
|-------|------------|---------------------|
| 35 | 1KS21EC097 | SRIPRIYA H G |
| 36 | 1KS21EC098 | SUMUKH P |
| 37 | 1KS21EC099 | SUNEETHA |
| 38 | 1KS21EC100 | SUNEHA S |
| 39 | 1KS21EC101 | SUPREETH A |
| 40 | 1KS21EC102 | SURABHI K R |
| 41 | 1KS21EC103 | SUSHEN KRISHNAPUR |
| 42 | 1KS21EC104 | TARUN M |
| 43 | 1KS21EC105 | TEJASHREE N |
| 44 | 1KS21EC106 | THARUN K V |
| 45 | 1KS21EC107 | THEJAS H V |
| 46 | 1KS21EC108 | THUSHAR CHERIAN |
| 47 | 1KS21EC109 | UDAYA KUMAR S R |
| 48 | 1KS21EC110 | VAISHNAVI B A |
| 49 | 1KS21EC111 | VARSHA JAYAKUMAR |
| 50 | 1KS21EC112 | VARSHA S DAVASKAR |
| 51 | 1KS21EC113 | VARSHITH S |
| 52 | 1KS21EC114 | VEERESH K N |
| 53 | 1KS21EC115 | VIDYA I |
| 54 | 1KS21EC116 | VIDYA RAWAL D |
| 55 | 1KS21EC117 | VIDYASHREE R |
| 56 | 1KS21EC118 | VIJAY YADAV R |
| 57 | 1KS21EC120 | VYSHAK G R |
| 58 | 1KS21EC121 | YASHWANTH.M |



K. Kumar. G.
 PRINCIPAL
 K.S. INSTITUTE OF TECHNOLOGY
 BENGALURU - 560 109.

K.S.INSTITUTE OF TECHNOLOGY

Department of Training and Placements

INTERNSHIP PROGRAM _3rd Semester

BATCH 5 -COMPUTER SCIENCE AND DESIGN (OB - 105)

| SL.NO | USN | NAME OF THE STUDENT |
|-------|------------|--------------------------|
| 1 | 1KS21CG001 | A S N SREEYA |
| 2 | 1KS21CG002 | ABDUS SALAAM I |
| 3 | 1KS21CG003 | ABHILASHA PATIL |
| 4 | 1KS21CG004 | ANAGHA SHASTRY |
| 5 | 1KS21CG005 | ANKITHA DEVLOKAM |
| 6 | 1KS21CG006 | ARPITHA G R |
| 7 | 1KS21CG007 | B H RUCHIRA |
| 8 | 1KS21CG008 | BADARI PRASAD M |
| 9 | 1KS21CG009 | BHARAT R |
| 10 | 1KS21CG010 | BUDEN GOUDA |
| 11 | 1KS21CG011 | CHALLA DEEPIKA |
| 12 | 1KS21CG012 | DANDA AJITH KUMAR |
| 13 | 1KS21CG013 | DEEPIKA S |
| 14 | 1KS21CG014 | DEEPTHI G B |
| 15 | 1KS21CG015 | DHANUSH B K |
| 16 | 1KS21CG016 | DIVYA T |
| 17 | 1KS21CG017 | G PRADEEP |
| 18 | 1KS21CG018 | G YOGIRAM |
| 19 | 1KS21CG019 | GOVIND VENKATESHA SHETTY |
| 20 | 1KS21CG020 | HEMANTH M |
| 21 | 1KS21CG021 | KARTHIK C S |
| 22 | 1KS21CG022 | KEERTHANA LOKESH |
| 23 | 1KS21CG023 | KEERTHANA S |
| 24 | 1KS21CG024 | KEERTHANA S D |
| 25 | 1KS21CG025 | KUSHAL M J |
| 26 | 1KS21CG026 | KUSUM PAKIRA |
| 27 | 1KS21CG027 | MONISHA M |
| 28 | 1KS21CG028 | NEHA M R |

| SL.NO | USN | NAME OF THE STUDENT |
|-------|------------|----------------------|
| 29 | 1KS21CG029 | NISHANTH G K |
| 30 | 1KS21CG030 | PAVITHRAA G |
| 31 | 1KS21CG031 | PRATEEK C HIEMATH |
| 32 | 1KS21CG032 | PREETHAM H V |
| 33 | 1KS21CG033 | RAYALA SAI PRAKASH |
| 34 | 1KS21CG034 | RIYA NAIR |
| 35 | 1KS21CG035 | SANJANA SREENIVAS |
| 36 | 1KS21CG036 | SANJANA V |
| 37 | 1KS21CG037 | SANJAY P |
| 38 | 1KS21CG038 | SATHYA SAI SRI B S |
| 39 | 1KS21CG039 | SAVYASHREE S |
| 40 | 1KS21CG040 | SHALINI B |
| 41 | 1KS21CG041 | SHISHIRA MOHAN |
| 42 | 1KS21CG042 | SHIVANI ADHIKARI |
| 43 | 1KS21CG043 | SHREYAS G |
| 44 | 1KS21CG044 | SHREYAS M |
| 45 | 1KS21CG045 | SHRUTHI K RAJ |
| 46 | 1KS21CG046 | SUDARSHAN BABU A |
| 47 | 1KS21CG047 | SUMANA R |
| 48 | 1KS21CG048 | SUMANTH V SHET |
| 49 | 1KS21CG049 | TARUN JANGIR |
| 50 | 1KS21CG050 | THANUJA B |
| 51 | 1KS21CG051 | THEJAS B S |
| 52 | 1KS21CG052 | UNUGURU GIRI SANKAR |
| 53 | 1KS21CG053 | VAISHNAVI S |
| 54 | 1KS21CG054 | VARSHITHA S |
| 55 | 1KS21CG055 | VARSHITHA SRIDHAR |
| 56 | 1KS21CG056 | VIDHEESHA T M |
| 57 | 1KS21CG057 | VIGNESH U |
| 58 | 1KS21CG058 | VYSHNAVI S N |
| 59 | 1KS21CG059 | YEDDULAPALLI SAHITHI |



Principal
K.S. INSTITUTE OF TECHNOLOGY
BENGALURU - 560 109.

K.S.INSTITUTE OF TECHNOLOGY

Department of Training and Placements

INTERNSHIP PROGRAM _3rd Semester

BATCH 6 -ARTIFICIAL INTELLIGENCE AND MACHINE LEARNING +
MECHANICAL ENGINEERING (**OB - 106**)

| SL.NO | USN | NAME OF THE STUDENT |
|-------|------------|---------------------|
| 1 | 1KS21AI001 | ABHAY SURYA E |
| 2 | 1KS21AI002 | ADITHI R |
| 3 | 1KS21AI003 | ADITYA KALKUR |
| 4 | 1KS21AI004 | AMRUTHA M V |
| 5 | 1KS21AI005 | ANANYA B GOWDA |
| 6 | 1KS21AI006 | ANANYA PRAMOD |
| 7 | 1KS21AI007 | ANUSHREE R |
| 8 | 1KS21AI008 | APEKSHA I M |
| 9 | 1KS21AI009 | ARVIND N |
| 10 | 1KS21AI010 | BHUVAN S GOWDA |
| 11 | 1KS21AI011 | CHAITRA S |
| 12 | 1KS21AI012 | CHEZHAN S |
| 13 | 1KS21AI013 | CHIRAG V S |
| 14 | 1KS21AI014 | ESHWAR S |
| 15 | 1KS21AI015 | G C SAMBRAM |
| 16 | 1KS21AI016 | G VINAY KUMAR |
| 17 | 1KS21AI017 | HARIKRISHNA G |
| 18 | 1KS21AI018 | HARSHITHA A |
| 19 | 1KS21AI019 | HEMALATHA D R |
| 20 | 1KS21AI020 | JAYASHREE P R |
| 21 | 1KS21AI021 | K J ARUN |
| 22 | 1KS21AI022 | KARTHIK CHAVAN |
| 23 | 1KS21AI023 | KAVYA S |
| 24 | 1KS21AI024 | KEERTHANA R |
| 25 | 1KS21AI025 | LIKITHA K |
| 26 | 1KS21AI026 | LOCHAN K |
| 27 | 1KS21AI027 | LOKARANJAN B S |
| 28 | 1KS21AI028 | MODUPALLI MEGHANA |

| SL.NO | USN | NAME OF THE STUDENT |
|-------|------------|--------------------------|
| 29 | 1KS21AI029 | MRUDULA S R |
| 30 | 1KS21AI030 | NABIHA SHARIFF |
| 31 | 1KS21AI031 | NEERAJ P |
| 32 | 1KS21AI032 | NEHA K B |
| 33 | 1KS21AI033 | NILANJANA JAMINDAR |
| 34 | 1KS21AI034 | NITHIN HAREESH GOWDA S H |
| 35 | 1KS21AI035 | NITHISH GOWDA K J |
| 36 | 1KS21AI036 | NITHYA R |
| 37 | 1KS21AI037 | P LALIT SHEKHAR |
| 38 | 1KS21AI038 | PRAJWAL D |
| 39 | 1KS21AI039 | PUNYA SHREE T S |
| 40 | 1KS21AI040 | RACHANA P R |
| 41 | 1KS21AI041 | RAKSHITA S |
| 42 | 1KS21AI042 | SAHANA S |
| 43 | 1KS21AI043 | SAI NEHA D P |
| 44 | 1KS21AI044 | SAMANA M B |
| 45 | 1KS21AI045 | SANJANA O R |
| 46 | 1KS21AI046 | SHAMA S K |
| 47 | 1KS21AI047 | SHASHANK P |
| 48 | 1KS21AI048 | SHIVANI UPPIN |
| 49 | 1KS21AI049 | SUDEEP RANJAN |
| 50 | 1KS21AI050 | SUHAS R |
| 51 | 1KS21AI051 | SURABHI T G |
| 52 | 1KS21AI052 | TANUSHREE S |
| 53 | 1KS21AI053 | THRYAKSHARI S |
| 54 | 1KS21AI054 | VARNIKA V N |
| 55 | 1KS21AI055 | VENKATESH T |
| 56 | 1KS21AI056 | VINITH P |
| 57 | 1KS21AI057 | ZUHA SUHAIL |
| 58 | 1KS21ME001 | A ASLAM BASHA |
| 59 | 1KS21ME002 | DHANUSH R |
| 60 | 1KS21ME003 | HEMANTH H |
| 61 | 1KS21ME004 | K HARISH KUMAR |
| 62 | 1KS21ME005 | MANOJ T S |

| SL.NO | USN | NAME OF THE STUDENT |
|-------|------------|---------------------|
| 63 | 1KS21ME006 | N EKANTH |
| 64 | 1KS21ME007 | NITHIN KUMAR P |
| 65 | 1KS21ME008 | PAVAN K |
| 66 | 1KS21ME009 | PAVANKUMAR H |
| 67 | 1KS21ME010 | RAJESH KUMAR N G |
| 68 | 1KS21ME011 | ROHIT KUMAR S |



Skema.6
PRINCIPAL
K.S. INSTITUTE OF TECHNOLOGY
BENGALURU - 560 109.

AUDAZ

Audaz Ventures Pvt. Ltd.

#33, Sai Lotus, 2nd Floor, RR Nagar, Bangalore - 560098

Mobile: 9818019279

Email: info@audazlearning.com

To,

Dr. Harish R.,
Training & Placement Officer
K.S. Institute of Technology
Bengaluru, Karnataka - 560109

Dear Sir,

Please find below the detailed training & placement report for B.E. III Semester Training Program conducted from 11th October 2022 till 15th October 2022.

Report contains the following:

1. Program Objectives
2. Program Outcome
3. Trainer details
4. Modules covered

Regards,
Team Audaz

PROGRAM OBJECTIVES

- To enable students to communicate clearly and with impact by improving their verbal and non-verbal communication.
- To enhance interpersonal skills to students.
- To enable students to build a right thought process in tough situations.
- To enable students to develop emotional intelligence

PROGRAM OUTCOMES:

- Overcoming inferiority complex by way of presentations and other activities in the session.
- Building self confidence
- Becoming a team player
- Improving both verbal & nonverbal communication skills from placement perspective.
- Developing creative thought process and promoting innovative ideas.

TRAINER DETAILS

| Day | Date | Trainer Name |
|-------|-----------|--|
| Day 1 | 11-Oct-22 | Rumani, Anand, Aftab, Kavitha, Poonam, Anuradha |
| Day 2 | 12-Oct-22 | Rumani, Chaitra, Aftab, Kavitha, Poonam, Anuradha |
| Day 3 | 13-Oct-22 | Rumani, Anand, Nishida, Kavitha, Poonam, Anuradha |
| Day 4 | 14-Oct-22 | Chaitra, Anand, Aftab, Nishida, Kavitha, Poonam, Nishida |
| Day 5 | 15-Oct-22 | Chaitra, Anand, Aftab, Nishida, Kavitha, Poonam, Nishida |

MODULES COVERED

| Day | Date | Module Covered |
|-------|-----------|--|
| Day 1 | 11-Oct-22 | Professional Etiquettes & Self Management |
| Day 2 | 12-Oct-22 | Public Speaking & Team Building |
| Day 3 | 13-Oct-22 | Formal Writing & Creative Thinking |
| Day 4 | 14-Oct-22 | Business Language & Emotional Intelligence |
| Day 5 | 15-Oct-22 | Presentation Skills |

| | | | | | | | | | | | | | | | | | | |
|--|------------|-----------------------|----|----|----|----|----|----|----|----|----|----|----|----|----|----|----|----|
| 43 | 1KS21CS045 | KANISHK E R | 1 | 2 | 3 | 4 | 5 | A | A | A | A | A | A | A | A | A | 5 | |
| 44 | 1KS21CS046 | KARTHIK H N | A | 1 | 2 | 3 | # | 5 | 6 | 7 | 8 | 9 | 10 | A | 12 | 13 | A | 13 |
| 45 | 1KS21CS047 | KAUSHIK G V | 1 | 2 | 3 | 4 | A | 5 | 6 | 7 | 8 | A | A | A | 9 | 10 | A | 10 |
| 46 | 1KS21CS048 | KAVANA N | 1 | 2 | 3 | 4 | 5 | 6 | 7 | 8 | 9 | 10 | 11 | 12 | 13 | 14 | 15 | 15 |
| 47 | 1KS21CS049 | KAVYA B SINGH | A | A | A | A | A | A | A | A | A | A | A | A | A | A | A | 3 |
| 48 | 1KS21CS050 | KEERTHIKA S | 1 | 2 | 3 | 4 | 5 | 6 | 7 | 8 | 9 | 10 | A | 11 | 12 | 13 | 14 | 14 |
| 49 | 1KS21CS051 | KONGARA SREE SAI | A | A | A | 1 | A | 2 | 3 | 4 | 5 | 6 | 7 | A | 8 | 9 | 10 | 10 |
| 50 | 1KS21CS052 | KUNAPALLI LAASYASHRRE | 1 | 2 | 3 | 4 | 5 | 6 | 7 | 8 | 9 | 10 | 11 | 12 | 13 | 14 | 15 | 16 |
| 51 | 1KS21CS053 | L.LAVANYA | 1 | 2 | 3 | A | A | A | A | A | A | A | A | A | A | A | A | 03 |
| 52 | 1KS21CS054 | M VAIBHAV NAYAK | 1 | 2 | A | 3 | A | A | 4 | 5 | A | 6 | 7 | A | A | A | A | 7 |
| 53 | 1KS21CS055 | MADHU SNEHA SHREE S | 1 | 2 | 3 | 4 | 5 | 6 | 7 | 8 | 9 | 10 | 11 | 12 | 13 | 14 | 15 | 15 |
| 54 | 1KS21CS056 | MANIKANTH | A | 1 | 2 | 3 | A | 4 | 5 | 6 | 7 | A | A | A | 8 | 9 | 10 | 10 |
| 55 | 1KS21CS057 | MANJUNATH | A | 1 | 2 | 3 | A | 4 | 5 | 6 | 7 | 8 | A | A | 9 | 10 | 11 | 11 |
| 56 | 1KS21CS058 | MANOJ KUMAR S | A | A | A | A | A | A | A | A | A | A | A | A | A | A | A | A |
| 57 | 1KS21CS059 | MAUSAM KUMAR | 1 | 2 | 3 | A | A | A | A | A | A | A | A | A | A | A | A | A |
| 58 | 1KS21CS060 | MAYA | 1 | 2 | 3 | 4 | A | A | 5 | 6 | 7 | 8 | 9 | 10 | 11 | 12 | 13 | 13 |
| No. of Students Absent | | | 12 | 9 | 11 | 16 | 32 | 28 | 11 | 11 | 14 | 13 | 25 | 39 | 27 | 29 | 32 | 13 |
| No. of Students Present | | | 46 | 49 | 47 | 42 | 36 | 30 | 49 | 49 | 46 | 45 | 33 | 19 | 27 | 29 | 26 | 3 |
| Signature of trainer/placement coordinator | | | A | A | A | A | A | A | A | A | A | A | A | A | A | A | A | A |





K.S INSTITUTE OF TECHNOLOGY
CONSOLIDATED ATTENDANCE FOR INTERNSHIP PROGRAM
COMPUTER SCIENCE AND ENGINEERING - OB 008

| II YEAR | | | III SEMESTER | | | | | | | | | BATCH 2 | | | | | | |
|---------|------------|--------------------------|--------------|---|---|------------|---|---|------------|---|---|------------|----|----|------------|----|----|-------|
| S. No | USN | NAME OF THE STUDENT | Dates | | | | | | | | | | | | | | | TOTAL |
| | | | 11/10/2022 | | | 12/10/2022 | | | 13/10/2022 | | | 14/10/2022 | | | 15/10/2022 | | | |
| | | | 1 | 2 | 3 | 4 | 5 | 6 | 7 | 8 | 9 | 10 | 11 | 12 | 13 | 14 | 15 | |
| 1 | 1KS21CS061 | MONIKA D | 1 | 2 | 3 | 4 | 5 | 6 | 7 | 8 | 9 | 10 | 11 | 12 | 13 | 14 | 15 | 15 |
| 2 | 1KS21CS062 | N VIDYASAGAR | 1 | 2 | 3 | 4 | 5 | 6 | 7 | A | A | 8 | A | A | 9 | A | A | 09 |
| 3 | 1KS21CS063 | NAGADARSHAN R P | 1 | 2 | 3 | 4 | 5 | 6 | 7 | 8 | 9 | 10 | 11 | 12 | 13 | 14 | 15 | 15 |
| 4 | 1KS21CS064 | NAGASHREE A | 1 | 2 | 3 | A | A | A | 4 | 5 | 6 | 7 | 8 | 9 | 10 | 11 | A | 11 |
| 5 | 1KS21CS065 | NAREN RAKSHITH K V | 1 | A | A | 2 | 3 | A | A | A | A | 4 | 5 | A | A | A | A | 5 |
| 6 | 1KS21CS066 | NETYAM SHIVSARAN | 1 | 2 | 3 | 4 | 5 | 6 | 7 | 8 | 9 | 10 | 11 | 12 | 13 | 14 | A | 14 |
| 7 | 1KS21CS067 | NIKHIL SAI K V | A | A | A | A | A | A | A | A | A | A | A | A | A | A | A | 00 |
| 8 | 1KS21CS068 | NOOR ZAHIDA | 1 | 2 | 3 | 4 | 5 | 6 | 7 | 8 | 9 | 10 | 11 | A | A | A | A | 12 |
| 9 | 1KS21CS069 | OMKAR ARJUN MAGADUM | A | A | A | A | A | A | A | A | A | A | A | A | A | A | A | A |
| | 1KS21CS070 | POOJA G | 1 | 2 | 3 | 4 | 5 | 6 | 7 | 8 | 9 | 10 | 11 | 12 | 13 | 14 | A | 14 |
| 11 | 1KS21CS071 | POOJITHA M V | 1 | 2 | 3 | 4 | 5 | 6 | 7 | 8 | A | 9 | 10 | 11 | 12 | 13 | A | 13 |
| 12 | 1KS21CS072 | POOJITHA R | 1 | 2 | 3 | 4 | 5 | 6 | 7 | 8 | 9 | A | A | A | A | 10 | 11 | 11 |
| 13 | 1KS21CS073 | PRANAY G | A | A | A | A | A | A | A | A | A | A | A | A | A | A | A | 0 |
| 14 | 1KS21CS074 | PRIYANKA V | 1 | 2 | 3 | 4 | 5 | 6 | 7 | 8 | 9 | 10 | 11 | 12 | 13 | 14 | 15 | 15 |
| 15 | 1KS21CS075 | R AISHWARYA | 1 | 2 | 3 | 4 | A | A | 5 | 6 | 7 | 8 | 9 | 10 | A | 12 | 13 | 13 |
| 16 | 1KS21CS076 | R HARSHA | 1 | A | 2 | 3 | 4 | 5 | 6 | A | A | A | A | A | A | 8 | A | 8 |
| 17 | 1KS21CS077 | RAKSHITA G SATARADDI | 1 | 2 | 3 | 4 | 5 | 6 | 7 | 8 | 9 | 10 | 11 | 12 | 13 | 14 | A | 14 |
| 18 | 1KS21CS078 | RAKSHITHA D H | 1 | 2 | 3 | 4 | 5 | 6 | 7 | 8 | 9 | 10 | 11 | 12 | 13 | 14 | A | 14 |
| 19 | 1KS21CS079 | RASHMI B PHULARI | 1 | 2 | 3 | 4 | 5 | 6 | 7 | 8 | 9 | 10 | 11 | 12 | 13 | 14 | 15 | 15 |
| 20 | 1KS21CS080 | RAVEESH PRASAD M | 1 | 2 | 3 | 4 | 5 | 6 | 7 | 8 | 9 | 10 | 11 | 12 | 13 | 14 | 15 | 15 |
| 21 | 1KS21CS081 | RAVITEJ ARJUN KAKHANDAKI | A | A | A | A | A | A | A | A | A | A | A | A | A | A | A | 00 |
| 22 | 1KS21CS082 | REDDY TEJASWINI A | 1 | 2 | 3 | 4 | 5 | 6 | 7 | 8 | 9 | 10 | 11 | 12 | 13 | 14 | 15 | 15 |
| 23 | 1KS21CS083 | RUSHIKESH B | 1 | 2 | 3 | 4 | 5 | 6 | 7 | 8 | 9 | 10 | 11 | 12 | 13 | 14 | A | 14 |
| 24 | 1KS21CS084 | RUTHU M R | 1 | 2 | 3 | 4 | 5 | 6 | 7 | 8 | 9 | 10 | 11 | 12 | 13 | 14 | A | 14 |
| 25 | 1KS21CS085 | SAGAR S N | 1 | A | 2 | 3 | 4 | 5 | 6 | A | A | A | A | A | A | A | A | 06 |
| | 1KS21CS086 | SAMRAT SINGH | A | A | A | A | A | A | A | A | A | A | A | A | A | A | A | 00 |
| 27 | 1KS21CS087 | SANTHOSH K A | 1 | 2 | 3 | 4 | 5 | 6 | 7 | 8 | 9 | 10 | 11 | 12 | 13 | 14 | 15 | 15 |
| 28 | 1KS21CS088 | SHAMITHA RAVISHANKAR | 1 | 2 | 3 | 4 | 5 | 6 | 7 | 8 | 9 | 10 | 11 | 12 | 13 | 14 | A | 14 |
| 29 | 1KS21CS089 | SHEETAL NAIK | 1 | 2 | 3 | 4 | 5 | 6 | 7 | 8 | 9 | 10 | 11 | 12 | 13 | 14 | 15 | 15 |
| 30 | 1KS21CS090 | SHEETHAL G | 1 | 2 | 3 | A | 4 | 5 | 6 | 7 | 8 | 9 | 10 | 11 | 12 | 13 | 14 | 14 |
| 31 | 1KS21CS091 | SHEETHAL R | 1 | 2 | 3 | 4 | 5 | 6 | 7 | 8 | 9 | 10 | 11 | 12 | 13 | 14 | A | 14 |
| 32 | 1KS21CS092 | SHOEB AHMED QUADRI | A | A | A | A | A | A | A | A | A | A | A | A | A | A | A | 00 |
| 33 | 1KS21CS093 | SHREYAS C | A | A | A | A | A | A | A | A | A | A | A | A | A | A | A | 00 |
| 34 | 1KS21CS094 | SINDHU MEGHA | 1 | 2 | 3 | A | 5 | 6 | 7 | 8 | 9 | 10 | 11 | 12 | 13 | 14 | 15 | 15 |
| 35 | 1KS21CS095 | SKANDA KUMAR H S | 1 | 2 | 3 | 4 | 5 | 6 | 7 | 8 | 9 | 10 | 11 | 12 | 13 | 14 | 15 | 15 |
| 36 | 1KS21CS096 | SNEHA S | 1 | 2 | 3 | 4 | 5 | 6 | 7 | 8 | 9 | 10 | 11 | 12 | 13 | 14 | 15 | 15 |
| 37 | 1KS21CS097 | SOUJANYA N | 1 | 2 | 3 | 4 | 5 | 6 | 7 | 8 | 9 | 10 | 11 | 12 | 13 | 14 | 15 | 15 |
| 38 | 1KS21CS098 | SRINIDHI MADHUSUDHAN | 1 | 2 | 3 | A | A | A | 4 | A | A | 5 | 6 | 7 | 8 | 9 | 10 | 10 |
| 39 | 1KS21CS099 | SUMAN B S | 1 | 2 | 3 | 4 | 5 | 6 | 7 | 8 | 9 | 10 | 11 | 12 | 13 | 14 | 15 | 15 |
| 40 | 1KS21CS100 | SUMEDHA R | 1 | 2 | 3 | 4 | 5 | 6 | 7 | 8 | 9 | 10 | 11 | 12 | A | A | A | 12 |
| 41 | 1KS21CS101 | SUMUKHA S BHARADWAJ | 1 | 2 | 3 | 4 | 5 | 6 | 7 | 8 | 9 | 10 | 11 | 12 | 13 | 14 | 15 | 15 |
| 42 | 1KS21CS102 | SUNIDHI P | 1 | 2 | 3 | 4 | 5 | 6 | 7 | 8 | 9 | 10 | 11 | 12 | 13 | 14 | 15 | 15 |
| 43 | 1KS21CS103 | SURESH C | 1 | 2 | 3 | 4 | 5 | 6 | 7 | 8 | 9 | 10 | 11 | 12 | 13 | 14 | A | 14 |
| 44 | 1KS21CS104 | SUSHMITHA M | 1 | 2 | 3 | 4 | 5 | 6 | 7 | 8 | 9 | A | A | A | 10 | 11 | A | 11 |

| | | | | | | | | | | | | | | | | | | |
|--|------------|---------------------|--------------------|--------------------|--------------------|--------------------|--------------------|--------------------|--------------------|--------------------|--------------------|--------------------|--------------------|--------------------|--------------------|--------------------|--------------------|--------------------|
| 45 | 1KS21CS105 | SWAROOP S KOWSHIK | 1 | 2 | 3 | 4 | 5 | 6 | 7 | 8 | 9 | 10 | 11 | 12 | 13 | 14 | 15 | 15 |
| 46 | 1KS21CS106 | TEJASHREE GOWDA Y K | 1 | 2 | 3 | 4 | 5 | 6 | 7 | 8 | 9 | 10 | 11 | 12 | 13 | 14 | 15 | 15 |
| 47 | 1KS21CS107 | UJWAL M L | 1 | 2 | 3 | 4 | 5 | 6 | 7 | 8 | 9 | 10 | 11 | 12 | 13 | 14 | 15 | 15 |
| 48 | 1KS21CS108 | V M TEJUS | 1 | 2 | 3 | 4 | A | A | 5 | 6 | 7 | 8 | 9 | 10 | 11 | 12 | 13 | 13 |
| 49 | 1KS21CS109 | VAISHALI BHOSLE | 1 | 2 | 3 | A | A | A | A | 5 | 6 | 7 | 8 | 9 | 10 | 11 | 12 | 12 |
| 50 | 1KS21CS110 | VANISHREE | 1 | 2 | 3 | 4 | 5 | 6 | 7 | 8 | 9 | 10 | 11 | 12 | 13 | 14 | A | 14 |
| 51 | 1KS21CS111 | VARSHA H R | 1 | 2 | 3 | 4 | 5 | 6 | 7 | 8 | 9 | 10 | 11 | 12 | 13 | 14 | 15 | 15 |
| 52 | 1KS21CS112 | VARUN SAI V | 1 | 2 | 3 | 4 | 5 | 6 | 7 | 8 | 9 | 10 | 11 | 12 | 13 | 14 | 15 | 15 |
| 53 | 1KS21CS113 | VIBHA GOVIN S | A | A | A | A | 5 | 6 | 7 | 8 | 9 | 10 | 11 | 12 | 13 | 14 | 15 | 15 |
| 54 | 1KS21CS114 | VIJETHA S | 1 | 2 | 3 | 4 | 5 | 6 | 7 | 8 | 9 | 10 | 11 | 12 | 13 | 14 | 15 | 15 |
| 55 | 1KS21CS115 | VILAS V | 1 | 2 | 3 | 4 | 5 | 6 | 7 | 8 | 9 | 10 | 11 | 12 | A | A | A | 12 |
| 56 | 1KS21CS116 | VISHAL KAMAN | 1 | 2 | 3 | 4 | 5 | 6 | 7 | 8 | 9 | 10 | 11 | 12 | 13 | 14 | 15 | 15 |
| 57 | 1KS21CS117 | YASHAS D GOWDA | 1 | 2 | 3 | 4 | 5 | 6 | 7 | 8 | 9 | 10 | 11 | 12 | 13 | 14 | 15 | 15 |
| 58 | 1KS21CS118 | YASHASHWINI R | 1 | 2 | 3 | 4 | 5 | 6 | 7 | 8 | 9 | 10 | 11 | 12 | 13 | 14 | 15 | 15 |
| No. of Students Absent | | | 7 | 11 | 9 | 12 | 10 | 13 | 6 | 11 | 13 | 11 | 12 | 10 | 14 | 14 | 28 | |
| No. of Students Present | | | 51 | 47 | 49 | 46 | 48 | 45 | 52 | 46 | 45 | 47 | 48 | 46 | 44 | 44 | 30 | |
| Signature of trainer/placement coordinator | | | <i>[Signature]</i> | <i>[Signature]</i> | <i>[Signature]</i> | <i>[Signature]</i> | <i>[Signature]</i> | <i>[Signature]</i> | <i>[Signature]</i> | <i>[Signature]</i> | <i>[Signature]</i> | <i>[Signature]</i> | <i>[Signature]</i> | <i>[Signature]</i> | <i>[Signature]</i> | <i>[Signature]</i> | <i>[Signature]</i> | <i>[Signature]</i> |





K.S INSTITUTE OF TECHNOLOGY
CONSOLIDATED ATTENDANCE FOR INTERNSHIP PROGRAM
ELECTRONICS AND COMMUNICATION ENGINEERING - OB 101

Morning - 9:30 a.m
 - 11:30 a.m
 - 2:15 p.m

| II YEAR | | | III SEMESTER | | | | | | | | | BATCH 3 | | | | | | |
|---------|------------|---------------------|--------------|---|---|------------|---|---|------------|---|---|------------|----|----|------------|----|----|-------|
| S. No | USN | NAME OF THE STUDENT | Dates | | | | | | | | | | | | | | | TOTAL |
| | | | 11/10/2022 | | | 12/10/2022 | | | 13/10/2022 | | | 14/10/2022 | | | 15/10/2022 | | | |
| | | | 1 | 2 | 3 | 4 | 5 | 6 | 7 | 8 | 9 | 10 | 11 | 12 | 13 | 14 | 15 | |
| 1 | 1KS21EC001 | AADHYA B N | ✓ | 2 | 3 | 4 | A | A | 5 | 6 | 7 | 8 | 9 | 10 | 11 | 12 | 13 | 13 |
| 2 | 1KS21EC002 | ABHIJITH R | ✓ | 2 | 3 | 4 | 5 | 6 | 7 | 8 | 9 | 10 | 11 | 12 | 13 | 14 | 15 | 15 |
| 3 | 1KS21EC003 | ABHISHEK H C | ✓ | 2 | 3 | 4 | A | A | 5 | 6 | 7 | A | 8 | 9 | 10 | A | A | 10 |
| 4 | 1KS21EC004 | ABHISHEK T S | ✓ | 2 | 3 | 4 | 5 | 6 | 7 | 8 | 9 | 10 | 11 | 12 | 13 | 14 | 15 | 15 |
| 5 | 1KS21EC005 | AISHWARYA A | ✓ | 2 | 3 | 4 | 5 | 6 | A | A | A | 7 | 8 | 9 | 10 | 11 | 12 | 12 |
| 6 | 1KS21EC006 | AKSHAY C | ✓ | 2 | 3 | 4 | 5 | 6 | 7 | 8 | 9 | 10 | 11 | 12 | 13 | 14 | 15 | 15 |
| 7 | 1KS21EC007 | AKSHAY M S | ✓ | A | A | 2 | 3 | 4 | 5 | 6 | 7 | A | A | A | 8 | 9 | 10 | 10 |
| 8 | 1KS21EC008 | ANAGHA PRAKASH | ✓ | 2 | 3 | 4 | A | 5 | 6 | 7 | 8 | 9 | 10 | 11 | 12 | 13 | 14 | 14 |
| 9 | 1KS21EC009 | ANIRUDHA R BHAT | ✓ | 2 | 3 | 4 | A | A | 5 | 6 | 7 | A | A | A | 8 | 9 | 10 | 10 |
| 10 | 1KS21EC010 | ARCHANA G M | ✓ | 2 | 3 | 4 | A | A | 5 | 6 | 7 | A | A | A | 8 | 9 | 10 | 10 |
| 11 | 1KS21EC011 | ARCHANA M | ✓ | 2 | 3 | 4 | A | A | 5 | 6 | 7 | 8 | 9 | 10 | 11 | 12 | 13 | 13 |
| 12 | 1KS21EC012 | ARJUN BHARADWAJ | ✓ | 2 | 3 | 4 | 5 | 6 | 7 | 8 | 9 | 10 | 11 | 12 | 13 | 14 | 15 | 15 |
| 13 | 1KS21EC013 | ASHCHARYA N B | ✓ | 2 | 3 | 4 | A | A | 5 | 6 | 7 | 8 | 9 | 10 | 11 | 12 | 13 | 13 |
| 14 | 1KS21EC014 | ASHWIN S R | ✓ | 2 | 3 | 4 | A | A | 5 | 6 | 7 | 8 | 9 | 10 | 11 | 12 | 13 | 13 |
| 15 | 1KS21EC015 | B N JEEVAN | A | 1 | 2 | 3 | 4 | A | A | 5 | 6 | 7 | 8 | 9 | 10 | 11 | 12 | 12 |
| 16 | 1KS21EC016 | B P SAMARTH | ✓ | A | A | A | A | A | A | A | A | A | A | A | A | A | A | 10 |
| 17 | 1KS21EC017 | B S BHARGAV | A | A | A | A | A | A | A | A | A | A | A | A | A | A | A | 10 |
| 18 | 1KS21EC018 | BHAVYA K | ✓ | 2 | 3 | 4 | 5 | 6 | 7 | 8 | 9 | 10 | 11 | 12 | 13 | 14 | 15 | 15 |
| 19 | 1KS21EC019 | BHUVANA H | A | A | A | 1 | 2 | 3 | 4 | 5 | 6 | 7 | 8 | 9 | 10 | 11 | 12 | 12 |
| 20 | 1KS21EC020 | BINDUSHREE S | ✓ | 2 | 3 | 4 | 5 | 6 | 7 | 8 | 9 | 10 | 11 | 12 | 13 | 14 | 15 | 15 |
| 21 | 1KS21EC021 | CHINTAN D S | ✓ | 2 | 3 | 4 | 5 | 6 | 7 | 8 | 9 | 10 | 11 | 12 | 13 | 14 | 15 | 15 |
| 22 | 1KS21EC022 | CHIRAG S | ✓ | A | A | A | 2 | 3 | 4 | 5 | 6 | 7 | 8 | 9 | 10 | 11 | 12 | 12 |
| 23 | 1KS21EC023 | CHIRANTH V V | ✓ | 2 | 3 | 4 | 5 | 6 | 7 | 8 | 9 | 10 | 11 | 12 | 13 | 14 | 15 | 15 |
| 24 | 1KS21EC024 | DAGGUPATI CHARITHA | A | A | A | A | A | A | 1 | 2 | 3 | 4 | 5 | 6 | 7 | 8 | 9 | 9 |
| 25 | 1KS21EC025 | DAMINI S | A | A | A | 1 | 2 | 3 | 4 | 5 | 6 | 7 | 8 | 9 | 10 | 11 | 12 | 12 |
| 26 | 1KS21EC026 | DEEKSHA H K | ✓ | 2 | 3 | 4 | A | A | 5 | 6 | 7 | 8 | 9 | 10 | 11 | 12 | 13 | 13 |
| 27 | 1KS21EC027 | DEEPIKA D | ✓ | 2 | 3 | 4 | A | A | 5 | 6 | 7 | 8 | 9 | 10 | 11 | 12 | 13 | 13 |
| 28 | 1KS21EC028 | GAGAN V | A | 1 | 2 | 3 | 4 | 5 | 6 | 7 | 8 | 9 | 10 | 11 | 12 | 13 | 14 | 14 |
| 29 | 1KS21EC029 | GAGANA SINDHU N | ✓ | 2 | 3 | 4 | 5 | 6 | 7 | 8 | 9 | 10 | 11 | 12 | 13 | 14 | 15 | 15 |
| 30 | 1KS21EC030 | GREESHMA S | A | A | A | A | A | A | A | A | A | A | A | A | A | A | A | 10 |
| 31 | 1KS21EC031 | GURUSHANKARA M | ✓ | 2 | 3 | 4 | A | A | 5 | 6 | 7 | 8 | 9 | 10 | 11 | 12 | 13 | 13 |
| 32 | 1KS21EC032 | HARINI.L | ✓ | A | A | 2 | 3 | 4 | 5 | 6 | 7 | 8 | 9 | 10 | 11 | 12 | 13 | 13 |
| 33 | 1KS21EC033 | HEMANTH D R | ✓ | 2 | 3 | 4 | 5 | 6 | 7 | 8 | 9 | 10 | 11 | 12 | 13 | 14 | 15 | 15 |
| 34 | 1KS21EC035 | KAMBHAMPATI VIVEK | A | A | A | A | A | A | A | A | A | A | A | A | A | A | A | 10 |
| 35 | 1KS21EC036 | KARAN S | ✓ | 2 | 3 | 4 | 5 | 6 | 7 | 8 | 9 | 10 | 11 | 12 | 13 | 14 | 15 | 15 |
| 36 | 1KS21EC037 | KEERTHANA S | ✓ | 2 | 3 | 4 | A | A | 5 | 6 | 7 | 8 | 9 | 10 | 11 | 12 | 13 | 13 |
| 37 | 1KS21EC038 | KOMALA N | A | A | A | 1 | 2 | 3 | 4 | 5 | 6 | 7 | 8 | 9 | 10 | 11 | 12 | 12 |
| 38 | 1KS21EC039 | KUSHAL GOWDA U | ✓ | A | A | A | 2 | 3 | 4 | 5 | 6 | 7 | 8 | 9 | 10 | 11 | 12 | 12 |
| 39 | 1KS21EC040 | KUSUMA M S | A | 1 | A | 2 | 3 | 4 | 5 | 6 | 7 | 8 | 9 | 10 | 11 | 12 | 13 | 13 |
| 40 | 1KS21EC041 | LIKITHA L | ✓ | 2 | 3 | 4 | 5 | 6 | 7 | 8 | 9 | 10 | 11 | 12 | 13 | 14 | 15 | 15 |
| 41 | 1KS21EC042 | LOHIT HOOLAGERI | ✓ | A | A | 2 | 3 | 4 | 5 | 6 | 7 | 8 | 9 | 10 | 11 | 12 | 13 | 13 |
| 42 | 1KS21EC043 | LOHITH B | A | A | A | A | A | A | A | A | A | A | A | A | A | A | A | 10 |
| 43 | 1KS21EC044 | LOHITH S | A | A | A | 1 | 2 | 3 | 4 | 5 | 6 | 7 | 8 | 9 | 10 | 11 | 12 | 12 |
| 44 | 1KS21EC045 | MANOJ T V | A | A | A | A | 1 | 2 | 3 | 4 | 5 | 6 | 7 | 8 | 9 | 10 | 11 | 11 |

| | | | | | | | | | | | | | | | | | | | | |
|--|------------|-----------------------|----|----|----|----|----|----|----|----|----|----|----|----|----|----|----|----|-----|-----|
| 45 | 1KS21EC046 | MEGHANA N | A | A | A | A | A | A | A | A | A | A | A | A | A | A | A | A | (A) | |
| 46 | 1KS21EC047 | MISBA M | A | 1 | 2 | A | 3 | 4 | 5 | 6 | 7 | 8 | 9 | A | 8 | 9 | A | 10 | 11 | (A) |
| 47 | 1KS21EC048 | MITHUN C | 1 | 2 | 3 | 4 | 5 | 6 | 7 | 8 | 9 | 10 | 11 | 12 | 13 | 14 | 15 | 15 | | |
| 48 | 1KS21EC049 | MONISHA D | 1 | 2 | 3 | 4 | 5 | 6 | 7 | 8 | 9 | 10 | 11 | 12 | 13 | 14 | 15 | 15 | | |
| 49 | 1KS21EC050 | MUTTHULURU SAI HIMAJA | A | A | A | A | A | A | 1 | 2 | A | 3 | A | A | A | A | A | A | 03 | |
| 50 | 1KS21EC051 | NANDAN K | 1 | A | 2 | 3 | 4 | 5 | 6 | 7 | 8 | 9 | 10 | 11 | 12 | A | A | A | 12 | |
| 51 | 1KS21EC052 | NANDAN P B | A | A | A | A | A | A | A | A | A | A | A | A | A | A | A | A | (A) | |
| 52 | 1KS21EC053 | NARAHARI N JOSHI | 1 | 2 | 3 | 4 | 5 | 6 | 7 | 8 | 9 | 10 | 11 | 12 | A | A | A | A | 12 | |
| 53 | 1KS21EC054 | NAVEEN S | A | A | A | A | A | A | A | A | A | A | A | A | A | A | A | A | (A) | |
| 54 | 1KS21EC055 | NAYANA J | A | A | A | 1 | 2 | 3 | A | A | 4 | A | 5 | A | A | A | A | A | 05 | |
| 55 | 1KS21EC056 | NAYANA S | A | A | A | A | A | A | A | 1 | 2 | A | A | A | A | A | 3 | 4 | 04 | |
| 56 | 1KS21EC057 | NIDHI R | A | 1 | 2 | 3 | A | A | A | 5 | 6 | 7 | 8 | 9 | 10 | 11 | 12 | 12 | | |
| 57 | 1KS21EC058 | OMKAR N BHUJARKAR | A | 1 | 2 | A | 3 | 4 | A | 5 | 6 | 7 | 8 | 9 | 10 | 11 | 12 | 12 | | |
| 58 | 1KS21EC059 | PAVAN M PAI | A | A | A | A | 1 | 2 | A | A | A | A | A | A | A | A | A | A | 02 | |
| 59 | 1KS21EC060 | POLURU MANJUNATH | A | A | A | A | A | A | A | A | A | A | A | A | A | A | A | A | (A) | |
| No. of Students Absent | | | 25 | 25 | 25 | 20 | 26 | 25 | 19 | 15 | 18 | 23 | 26 | 28 | 23 | 42 | 42 | | | |
| No. of Students Present | | | 34 | 34 | 34 | 39 | 33 | 30 | 40 | 44 | 41 | 36 | 33 | 31 | 36 | 17 | 17 | | | |
| Signature of trainer/placement coordinator | | | | | | | | | | | | | | | | | | | | |

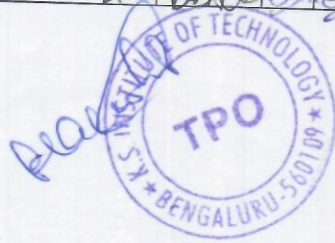

| | | |
|----------|------|--------------|
| 13/10/22 | → S1 | Ms. Nishida |
| | S2 | Ms. Nishida |
| | S3 | Ms. Nishida |
| 14/10/22 | → S1 | Chaitra A. I |
| | S2 | -//- |
| | S3 | -//- |
| 15/10/22 | → S1 | Anand Ravi |
| | S2 | -//- |
| | S3 | -//- |



K.S INSTITUTE OF TECHNOLOGY
CONSOLIDATED ATTENDANCE FOR INTERNSHIP PROGRAM
ELECTRONICS & COMMUNICATION ENGINEERING - OB 203

9:15 a.m
 11:30 a.m
 2:15 p.m.

| S. No | USN | NAME OF THE STUDENT | III SEMESTER | | | | | | | | | | | | | | | TOTAL |
|-------|------------|---------------------------|--------------|---|---|------------|---|---|------------|---|---|------------|----|----|------------|----|----|-------|
| | | | BATCH 4 | | | | | | | | | | | | | | | |
| | | | Dates | | | | | | | | | | | | | | | |
| | | | 11/10/2022 | | | 12/10/2022 | | | 13/10/2022 | | | 14/10/2022 | | | 15/10/2022 | | | |
| | | | 1 | 2 | 3 | 4 | 5 | 6 | 7 | 8 | 9 | 10 | 11 | 12 | 13 | 14 | 15 | |
| 1 | 1KS21EC061 | POOJA R | 1 | 2 | A | 3 | 4 | 5 | A | A | A | A | A | A | A | A | A | 05 |
| 2 | 1KS21EC062 | PRAJWAL D | A | A | A | A | A | A | A | A | A | A | A | A | A | A | A | (A) |
| 3 | 1KS21EC063 | PRAJWAL G V | A | 1 | 2 | A | 3 | 4 | 5 | 6 | 7 | 8 | 9 | 10 | A | A | A | 10 |
| 4 | 1KS21EC064 | PRAJWAL H S | A | A | A | A | A | A | A | A | A | A | A | A | A | A | A | (A) |
| 5 | 1KS21EC065 | PRAJWAL R | A | A | 1 | 2 | 3 | 4 | 5 | 6 | 7 | 8 | A | A | A | A | A | 08 |
| 6 | 1KS21EC066 | PRATHAM R SHANBHAG | 1 | 2 | A | A | A | A | A | A | A | A | A | A | A | A | A | 02 |
| 7 | 1KS21EC067 | PRAYAG SINGH S | A | 1 | A | A | 2 | 3 | A | 5 | 6 | 7 | A | A | A | A | A | 07 |
| 8 | 1KS21EC068 | PREETHAM M | A | 1 | A | A | A | A | B | 4 | A | 5 | A | A | A | A | A | 05 |
| 9 | 1KS21EC069 | PREKSHA S | 1 | 2 | 3 | 4 | 5 | 6 | 7 | 8 | 9 | 10 | A | A | A | A | A | 10 |
| 10 | 1KS21EC070 | PUNITH M | A | 1 | 2 | 3 | 4 | A | 5 | 6 | 7 | A | A | A | 8 | 9 | A | 09 |
| 11 | 1KS21EC071 | RAGHAVENDRA NARAYAN PUJAR | 1 | A | A | A | A | A | A | A | A | A | A | A | A | A | A | 01 |
| 12 | 1KS21EC072 | RAKSHITH S | 1 | 2 | 3 | A | 5 | 6 | 7 | 8 | 9 | 10 | 11 | 12 | A | A | A | 12 |
| 13 | 1KS21EC073 | RAKSHITHA M R | 1 | 2 | A | A | 3 | 4 | 5 | 6 | A | 7 | A | A | A | A | A | 07 |
| 14 | 1KS21EC074 | RAYADURG JOISH SHRIYA | 1 | 2 | 3 | A | A | A | 4 | 5 | A | 6 | A | A | A | A | A | 06 |
| 15 | 1KS21EC075 | REHAMAN SHARIFF | A | 1 | 2 | 3 | A | 5 | 6 | 7 | 8 | A | A | A | A | A | A | 10 |
| 16 | 1KS21EC076 | RITESH KUMAR SINHA | A | 1 | A | A | A | A | 2 | 3 | A | 4 | A | A | A | 9 | 10 | A |
| 17 | 1KS21EC077 | RITHIKA M | 1 | 2 | A | A | A | A | A | A | A | A | A | A | A | A | A | 04 |
| 18 | 1KS21EC078 | S HARI DHANUSH | A | A | A | A | A | A | A | A | A | A | A | A | A | A | A | 02 |
| 19 | 1KS21EC080 | S. SHAJITH ALI | 1 | 2 | A | A | A | A | A | A | A | A | A | A | A | A | A | (A) |
| 20 | 1KS21EC081 | SAGAR G S | A | 1 | 2 | A | 3 | 4 | 5 | 6 | 7 | 8 | 9 | A | A | A | A | 02 |
| 21 | 1KS21EC082 | SAI RAHUL N | A | 1 | A | 2 | 3 | 4 | 5 | A | A | 6 | A | A | A | A | A | 09 |
| 22 | 1KS21EC083 | SAMHITHA PRAKASH | A | A | A | A | A | A | A | A | A | A | A | A | A | A | A | 06 |
| 23 | 1KS21EC084 | SANJANA V | 1 | 2 | 3 | 4 | 5 | 6 | 7 | 8 | 9 | 10 | A | A | A | A | A | (A) |
| 24 | 1KS21EC085 | SANJAY G | A | A | A | 1 | 2 | 3 | 4 | A | 5 | 6 | 7 | 8 | A | A | A | 10 |
| 25 | 1KS21EC086 | SANJAY N | A | A | A | 1 | 2 | A | A | 3 | A | A | A | A | A | A | A | 08 |
| 26 | 1KS21EC087 | SANJAY P | A | A | A | 1 | 2 | A | A | 3 | A | A | A | A | A | A | A | 03 |
| 27 | 1KS21EC088 | SATHYAM KUMAR MANDAL S | 1 | 2 | 3 | 4 | 5 | 6 | 7 | 8 | 9 | 10 | A | A | A | A | A | 10 |
| 28 | 1KS21EC089 | SHAIK ARFATH | A | A | A | A | A | A | A | A | A | A | A | A | A | A | A | (A) |
| 29 | 1KS21EC090 | SHASHANK C U | 1 | 2 | 3 | 4 | 5 | 6 | 7 | 8 | 9 | 10 | A | 11 | 12 | 13 | A | 13 |
| 30 | 1KS21EC091 | SHREYAS RAGHAVENDRA V | 1 | 2 | A | A | A | A | A | A | A | A | A | A | A | A | A | 11 |
| 31 | 1KS21EC092 | SHWETHA V | 1 | 2 | 3 | 4 | 5 | 6 | 7 | 8 | 9 | 10 | A | A | A | A | A | 02 |
| 32 | 1KS21EC093 | SINDHU M NIMBAL | A | 1 | 2 | 3 | 4 | 5 | 6 | 7 | 8 | 9 | 10 | A | A | A | A | 07 |
| 33 | 1KS21EC095 | SPOORTHY M U | A | A | A | 1 | 2 | A | A | A | A | A | A | A | A | A | A | 02 |
| 34 | 1KS21EC096 | SRILAKSHMI G | 1 | 2 | 3 | 4 | 5 | 6 | 7 | 8 | 9 | 10 | A | A | A | A | A | 10 |
| 35 | 1KS21EC097 | SRIPRIYA H G | A | A | A | A | A | A | A | A | A | A | A | A | A | A | A | (A) |
| 36 | 1KS21EC098 | SUMUKH P | A | 1 | A | A | A | A | A | A | A | A | A | A | A | A | A | 01 |
| 37 | 1KS21EC099 | SUNEETHA | A | A | A | A | A | A | A | A | A | A | A | A | A | A | A | (A) |
| 38 | 1KS21EC100 | SUNEHA S | A | A | A | A | A | A | A | A | A | A | A | A | A | A | A | (A) |
| 39 | 1KS21EC101 | SUPREETH A | 1 | 2 | 3 | 4 | 5 | 6 | 7 | 8 | 9 | 10 | 11 | 12 | 13 | A | A | 13 |
| 40 | 1KS21EC102 | SURABHI K R | 1 | 2 | 3 | 4 | 5 | 6 | 7 | 8 | 9 | 10 | 11 | 12 | A | A | A | 12 |
| 41 | 1KS21EC103 | SUSHEN KRISHNAPUR | 1 | 2 | 3 | 4 | 5 | 6 | 7 | 8 | 9 | 10 | 11 | 12 | A | A | A | 12 |
| 42 | 1KS21EC104 | TARUN M | A | A | A | A | 1 | 2 | A | 3 | 4 | A | A | A | A | A | A | 04 |
| 43 | 1KS21EC105 | TEJASHREE N | A | A | A | A | A | A | A | A | A | A | A | A | A | A | A | (A) |
| 44 | 1KS21EC106 | THARUN K V | A | 1 | 2 | 3 | 4 | 5 | 6 | 7 | 8 | 9 | A | A | A | A | A | 03 |

| | | | | | | | | | | | | | | | | | |
|--|------------|-------------------|----|----|----|----|----|----|----|----|----|----|----|----|----|----|-----|
| 45 | 1KS21EC107 | THEJAS H V | A | 1 | A | A | A | 2 | 3 | A | 4 | A | A | A | A | A | 04 |
| 46 | 1KS21EC108 | THUSHAR CHERIAN | A | 1 | A | A | 2 | 3 | A | 4 | 5 | A | A | A | A | A | 05 |
| 47 | 1KS21EC109 | UDAYA KUMAR S R | A | A | A | A | A | A | A | A | A | A | A | A | A | A | (A) |
| 48 | 1KS21EC110 | VAISHNAVI B A | A | A | A | A | A | A | A | A | A | A | A | A | A | A | (A) |
| 49 | 1KS21EC111 | VARSHA JAYAKUMAR | 1 | 1 | 2 | 3 | 4 | 5 | 6 | 7 | 8 | 9 | 10 | 11 | A | A | A |
| 50 | 1KS21EC112 | VARSHA S DAVASKAR | A | A | A | A | A | A | A | A | A | A | A | A | A | A | (A) |
| 51 | 1KS21EC113 | VARSHITH S | A | A | A | A | A | A | 1 | A | 2 | A | A | A | A | A | 02 |
| 52 | 1KS21EC114 | VEERESH K N | A | A | A | A | 1 | A | A | A | A | A | A | A | A | A | 01 |
| 53 | 1KS21EC115 | VIDYA I | A | 1 | 2 | A | 3 | 4 | A | 5 | 6 | A | A | A | A | A | 06 |
| 54 | 1KS21EC116 | VIDYA RAWAL D | A | 1 | 2 | 3 | 4 | 5 | 6 | 7 | 8 | 9 | A | A | A | A | 03 |
| 55 | 1KS21EC117 | VIDYASHREE R | 1 | 2 | A | A | A | A | A | A | A | A | A | A | A | A | 02 |
| 56 | 1KS21EC118 | VIJAY YADAV R | A | 1 | A | A | A | 2 | 3 | A | A | A | A | A | A | A | 03 |
| 57 | 1KS21EC120 | VYSHAK G R | A | A | A | A | A | A | A | A | A | A | A | A | A | A | (A) |
| 58 | 1KS21EC121 | YASHWANTH.M | A | 1 | A | A | A | A | A | A | A | A | A | A | A | A | 01 |
| No. of Students Absent | | | 37 | 21 | 35 | 35 | 26 | 32 | 29 | 26 | 34 | 31 | 29 | 69 | 53 | 54 | 58 |
| No. of Students Present | | | 21 | 37 | 23 | 23 | 32 | 26 | 29 | 32 | 24 | 27 | 9 | 9 | 5 | 4 | 00 |
| Signature of trainer/placement coordinator | | | | | | | | | | | | | | | | | |



9) Rumani Bhandari.

10) Pooanam Brijaj

11) }
12) }



K.S INSTITUTE OF TECHNOLOGY
CONSOLIDATED ATTENDANCE FOR INTERNSHIP PROGRAM
COMPUTER SCIENCE AND DESIGN - OB 105

9:15 a.m
11:30 a.m
2:15 p.m

| II YEAR | | | III SEMESTER | | | | | | | | | BATCH 5 | | | | | | |
|---------|------------|--------------------------|--------------|---|---|------------|---|---|------------|---|---|------------|----|----|------------|----|----|-------|
| S. No | USN | NAME OF THE STUDENT | Dates | | | | | | | | | | | | | | | TOTAL |
| | | | 11/10/2022 | | | 12/10/2022 | | | 13/10/2022 | | | 14/10/2022 | | | 15/10/2022 | | | |
| | | | 1 | 2 | 3 | 4 | 5 | 6 | 7 | 8 | 9 | 10 | 11 | 12 | 13 | 14 | 15 | |
| 1 | 1KS21CG001 | A S N SREEYA | 1 | 2 | 3 | 4 | 5 | 6 | 7 | 8 | 9 | 10 | 11 | 12 | 13 | 14 | 15 | 15 |
| 2 | 1KS21CG002 | ABDUS SALAAM I | 1 | 2 | 2 | 2 | 2 | 2 | 2 | 2 | 2 | 2 | 2 | 2 | 2 | 2 | 2 | 02 |
| 3 | 1KS21CG003 | ABHILASHA PATIL | 1 | 2 | 3 | 4 | 5 | 6 | 7 | 8 | 9 | 10 | 11 | 12 | 13 | 14 | 15 | 15 |
| 4 | 1KS21CG004 | ANAGHA SHASTRY | 1 | 2 | 3 | 4 | 5 | 6 | 7 | 8 | 9 | 10 | 11 | 12 | 13 | 14 | 15 | 15 |
| 5 | 1KS21CG005 | ANKITHA DEVLOKAM | 1 | 2 | 3 | 4 | 5 | 6 | 7 | 8 | 9 | 10 | 11 | 12 | 13 | 14 | 15 | 15 |
| 6 | 1KS21CG006 | ARPITHA G R | 1 | 2 | 3 | 4 | 5 | 6 | 7 | 8 | 9 | 10 | 11 | 12 | 13 | 14 | 15 | 15 |
| 7 | 1KS21CG007 | B H RUCHIRA | 1 | 2 | 3 | 4 | 5 | 6 | 7 | 8 | 9 | 10 | 11 | 12 | 12 | 12 | 12 | 12 |
| 8 | 1KS21CG008 | BADARI PRASAD M | 1 | 2 | 3 | 4 | 5 | 6 | 7 | 8 | 9 | 10 | 11 | 12 | 13 | 14 | 15 | 15 |
| 9 | 1KS21CG009 | BHARAT R | A | A | A | A | A | A | A | A | A | A | A | A | A | A | A | A |
| 10 | 1KS21CG010 | BUDEN GOUDA | A | A | A | A | A | A | 2 | 3 | 3 | 3 | 3 | 3 | 3 | 3 | 3 | 10 |
| 11 | 1KS21CG011 | CHALLA DEEPIKA | 1 | 2 | 3 | 4 | 5 | 6 | 7 | 8 | 9 | 10 | 11 | 12 | 13 | 14 | 15 | 15 |
| 12 | 1KS21CG012 | DANDA AJITH KUMAR | 1 | A | A | A | A | A | 2 | 3 | 4 | 5 | 6 | 7 | 8 | 9 | 10 | 10 |
| 13 | 1KS21CG013 | DEEPIKA S | 1 | 2 | 3 | 4 | 5 | 6 | 7 | 8 | 9 | 10 | 11 | 12 | 13 | 14 | 15 | 15 |
| 14 | 1KS21CG014 | DEEPTHI G B | 1 | 2 | 3 | 4 | 5 | 6 | 7 | 8 | 9 | 10 | 11 | 12 | 13 | 14 | 15 | 15 |
| 15 | 1KS21CG015 | DHANUSH B K | 1 | 2 | 3 | 4 | 5 | 6 | 7 | 8 | 9 | 10 | 11 | 12 | 13 | 14 | 15 | 15 |
| 16 | 1KS21CG016 | DIVYA T | 1 | 2 | 3 | 4 | 5 | 6 | 7 | 8 | 9 | 10 | 11 | 12 | 13 | 14 | 15 | 15 |
| 17 | 1KS21CG017 | G PRADEEP | 1 | 2 | 3 | 4 | 4 | 5 | 6 | 7 | 8 | 10 | 10 | 11 | 12 | 12 | 12 | 12 |
| 18 | 1KS21CG018 | G YOGIRAM | 1 | 2 | 3 | A | 4 | 5 | 6 | 7 | 8 | 8 | 9 | 10 | 11 | 11 | 11 | 11 |
| 19 | 1KS21CG019 | GOVIND VENKATESHA SHETTY | 1 | 2 | 3 | 4 | 5 | 6 | 7 | 8 | 9 | 10 | 11 | 12 | 13 | 13 | 13 | 13 |
| 20 | 1KS21CG020 | HEMANTH M | 1 | 2 | 3 | 4 | 5 | 6 | 7 | 8 | 9 | 10 | 11 | 12 | 13 | 14 | 15 | 15 |
| 21 | 1KS21CG021 | KARTHIK C S | 1 | 2 | 3 | 4 | 5 | 6 | 7 | 8 | 9 | 10 | 11 | 12 | 13 | 13 | 13 | 13 |
| 22 | 1KS21CG022 | KEERTHANA LOKESH | A | A | A | 1 | 2 | 3 | 4 | 5 | 6 | 6 | 6 | 6 | 6 | 6 | 6 | 06 |
| 23 | 1KS21CG023 | KEERTHANA S | 1 | 2 | 3 | 3 | 3 | 3 | 3 | 3 | 3 | 4 | 5 | 6 | 7 | 8 | 9 | 09 |
| 24 | 1KS21CG024 | KEERTHANA S D | 1 | 2 | 3 | 4 | 5 | 6 | 6 | 6 | 6 | 7 | 8 | 9 | 10 | 10 | 10 | 10 |
| 25 | 1KS21CG025 | KUSHAL M J | 1 | 2 | 3 | 4 | 5 | 6 | 7 | 8 | 9 | 10 | 11 | 12 | 13 | 14 | 15 | 15 |
| 26 | 1KS21CG026 | KUSUM PAKIRA | 1 | 2 | 3 | 4 | 5 | 6 | 7 | 8 | 9 | 10 | 11 | 12 | 13 | 14 | 15 | 15 |
| 27 | 1KS21CG027 | MONISHA M | 1 | 2 | 3 | 4 | 5 | 6 | 7 | 8 | 9 | 10 | 11 | 12 | 13 | 14 | 15 | 15 |
| 28 | 1KS21CG028 | NEHA M R | 1 | 2 | 3 | 4 | 5 | 6 | 7 | 8 | 9 | 10 | 11 | 12 | 13 | 14 | 15 | 15 |
| 29 | 1KS21CG029 | NISHANTH G K | 1 | 2 | 3 | 4 | 5 | 6 | 7 | 8 | 9 | 10 | 11 | 12 | 13 | 14 | 15 | 15 |
| 30 | 1KS21CG030 | PAVITHRAA G | 1 | 2 | 3 | 4 | 5 | 6 | 7 | 8 | 9 | 10 | 11 | 12 | 13 | 14 | 15 | 15 |
| 31 | 1KS21CG031 | PRATEEK C HIEMATH | 1 | 2 | 3 | 4 | 5 | 6 | 7 | 8 | 9 | 9 | 9 | 9 | 9 | 9 | 9 | 9 |
| 32 | 1KS21CG032 | PREETHAM H V | 1 | 2 | 3 | 4 | 5 | 6 | 7 | 8 | 9 | 10 | 10 | 12 | 13 | 13 | 13 | 13 |
| 33 | 1KS21CG033 | RAYALA SAI PRAKASH | 1 | 2 | 3 | 4 | 5 | 6 | 7 | 8 | 9 | 10 | 11 | 12 | 13 | 14 | 15 | 15 |
| 34 | 1KS21CG034 | RIYA NAIR | 1 | 2 | 3 | 4 | 5 | 6 | 7 | 8 | 9 | 10 | 11 | 12 | 13 | 13 | 13 | 13 |
| 35 | 1KS21CG035 | SANJANA SREENIVAS | 1 | 2 | 3 | 4 | 5 | 6 | 7 | 8 | 9 | 10 | 11 | 12 | 13 | 13 | 13 | 13 |
| 36 | 1KS21CG036 | SANJANA V | A | 2 | 3 | 4 | 5 | 6 | 7 | 8 | 9 | 10 | 11 | 12 | 13 | 14 | 15 | 15 |
| 37 | 1KS21CG037 | SANJAY P | 1 | 2 | 3 | 4 | 5 | 6 | 7 | 8 | 9 | 10 | 11 | 12 | 13 | 13 | 13 | 13 |
| 38 | 1KS21CG038 | SATHYA SAI SRI B S | 1 | 2 | 3 | 4 | 5 | 6 | 7 | 8 | 9 | 10 | 11 | 12 | 13 | 14 | 15 | 15 |
| 39 | 1KS21CG039 | SAVYASHREE S | 1 | 2 | 3 | 4 | 5 | 6 | 7 | 8 | 9 | 10 | 11 | 12 | 13 | 13 | 13 | 13 |
| 40 | 1KS21CG040 | SHALINI B | 1 | 2 | 3 | 4 | 5 | 6 | 7 | 8 | 9 | 10 | 11 | 12 | 13 | 13 | 13 | 13 |
| 41 | 1KS21CG041 | SHISHIRA MOHAN | 1 | 2 | 3 | 4 | 5 | 6 | 7 | 8 | 8 | 9 | 10 | 10 | 11 | 11 | 11 | 11 |
| 42 | 1KS21CG042 | SHIVANI ADHIKARI | 1 | 2 | 3 | 4 | 5 | 6 | 7 | 8 | 9 | 10 | 11 | 12 | 13 | 14 | 15 | 15 |
| 43 | 1KS21CG043 | SHREYAS G | 1 | 2 | 3 | 4 | 5 | 6 | 7 | 8 | 9 | 10 | 11 | 12 | 13 | 13 | 13 | 13 |
| 44 | 1KS21CG044 | SHREYAS M | 1 | 2 | 3 | 4 | 5 | 6 | 7 | 8 | 9 | 10 | 11 | 12 | 13 | 13 | 13 | 13 |

| | | | 11/10 | | | 12/10 | | | 13/10 | | | 14/10 | | | 15/10 | | | |
|--|------------|----------------------|-------|----|----|-------|----|----|-------|----|----|-------|----|----|-------|----|----|----|
| 45 | 1KS21CG045 | SHRUTI K RAJ | 1 | 2 | 3 | 4 | 5 | 6 | 7 | 8 | 9 | 10 | 11 | 12 | 13 | 13 | 13 | 13 |
| 46 | 1KS21CG046 | SUDARSHAN BABU A | 1 | 2 | 2 | 2 | 2 | 2 | 3 | 4 | 5 | 6 | 7 | 8 | 8 | 8 | 8 | 08 |
| 47 | 1KS21CG047 | SUMANA R | 1 | 2 | 3 | 4 | 5 | 6 | 7 | 8 | 9 | 10 | 11 | 12 | 13 | 14 | 15 | 15 |
| 48 | 1KS21CG048 | SUMANTH V SHET | A | A | A | A | A | A | A | A | A | A | A | A | A | A | A | A |
| 49 | 1KS21CG049 | TARUN JANGIR | 1 | 2 | 3 | 4 | 5 | 6 | 7 | 8 | 9 | 10 | 11 | 12 | 13 | 13 | 13 | 13 |
| 50 | 1KS21CG050 | THANUJA B | 1 | 2 | 3 | 4 | 5 | 6 | 7 | 8 | 9 | 10 | 11 | 12 | 13 | 13 | 13 | 13 |
| 51 | 1KS21CG051 | THEJAS B S | 1 | 2 | 3 | 4 | 5 | 6 | 7 | 8 | 9 | 10 | 11 | 12 | 13 | 14 | 15 | 15 |
| 52 | 1KS21CG052 | UNUGURU GIRI SANKAR | 1 | 2 | 3 | 3 | 3 | 3 | 4 | 5 | 9 | 10 | 11 | 12 | 13 | 14 | 15 | 15 |
| 53 | 1KS21CG053 | VAISHNAVI S | 1 | 2 | 3 | 4 | 5 | 6 | 7 | 8 | 9 | 10 | 11 | 12 | 13 | 14 | 14 | 14 |
| 54 | 1KS21CG054 | VARSHITHA S | 1 | 2 | 3 | 4 | 5 | 6 | 7 | 8 | 9 | 10 | 11 | 12 | 13 | 14 | 15 | 15 |
| 55 | 1KS21CG055 | VARSHITHA SRIDHAR | 1 | 2 | 3 | 4 | 5 | 6 | 7 | 8 | 9 | 10 | 11 | 12 | 13 | 14 | 15 | 15 |
| 56 | 1KS21CG056 | VIDHEESHA T M | 1 | 2 | 3 | 4 | 5 | 6 | 7 | 8 | 9 | 10 | 11 | 12 | 13 | 14 | 15 | 15 |
| 57 | 1KS21CG057 | VIGNESH U | 1 | 2 | 3 | 4 | 5 | 6 | 7 | 8 | 9 | 10 | 11 | 12 | 13 | 13 | 13 | 13 |
| 58 | 1KS21CG058 | VYSHNAVI S N | 1 | 2 | 3 | 4 | 5 | 6 | 7 | 8 | 9 | 10 | 11 | 12 | 13 | 13 | 13 | 13 |
| 59 | 1KS21CG059 | YEDDULAPALLI SAHITHI | 1 | 2 | 3 | 3 | 3 | 3 | 4 | 5 | 9 | 10 | 11 | 12 | 13 | 12 | 12 | 12 |
| No. of Students Absent | | | 5 | 5 | 7 | 10 | 10 | 10 | 4 | 4 | 6 | 6 | 7 | 7 | 10 | 26 | 29 | |
| No. of Students Present | | | 54 | 54 | 52 | 49 | 49 | 49 | 55 | 55 | 53 | 53 | 52 | 52 | 49 | 33 | 30 | |
| Signature of trainer/placement coordinator | | | P | B | P | P | P | P | P | P | P | P | P | P | P | P | P | P |

Rumani
Anuradha,



| | | | | | | | | | | | | | | | | | | | | | |
|--|------------|------------------|----|----|----|----|----|----|----|----|----|----|----|----|----|----|----|---|---|---|----|
| 50 | 1KS21AI050 | SUHAS R | A | A | A | A | A | A | A | A | A | A | A | A | A | A | A | A | A | A | 10 |
| 51 | 1KS21AI051 | SURABHI T G | 1 | A | A | 1 | 2 | 3 | 1 | 2 | 3 | 1 | 2 | 3 | A | A | A | A | A | A | 10 |
| 52 | 1KS21AI052 | TANUSHREE S | 1 | 2 | 3 | 1 | 2 | 3 | 1 | 2 | 3 | 1 | 2 | 3 | A | A | A | A | A | A | 12 |
| 53 | 1KS21AI053 | THRYAKSHARI S | A | A | 1 | A | A | A | A | A | A | A | A | A | A | A | A | A | A | A | 01 |
| 54 | 1KS21AI054 | VARNIKA V N | 1 | 2 | 3 | 1 | 2 | 3 | 1 | 2 | 3 | 1 | 2 | 3 | 1 | 2 | 3 | 1 | 2 | 3 | 15 |
| 55 | 1KS21AI055 | VENKATESH T | 1 | 2 | A | 1 | 2 | 3 | 1 | 2 | 3 | 1 | 2 | 3 | 1 | 2 | 3 | 1 | 2 | 3 | 14 |
| 56 | 1KS21AI056 | VINITH P | 1 | 2 | 3 | A | A | A | A | A | A | 1 | 2 | 3 | 1 | 2 | 3 | 1 | 2 | 3 | 9 |
| 57 | 1KS21AI057 | ZUHA SUHAIL | 1 | 2 | 3 | A | A | A | A | A | A | 1 | 2 | 3 | 1 | 2 | 3 | 1 | 2 | 3 | 9 |
| 58 | 1KS21ME001 | A ASLAM BASHA | 1 | 2 | 3 | 1 | 2 | 3 | 1 | 2 | 3 | 1 | 2 | 3 | 1 | 2 | 3 | 1 | 2 | 3 | 15 |
| 59 | 1KS21ME002 | DHANUSH R | A | 1 | 2 | A | 2 | 3 | 1 | 2 | 3 | 1 | 2 | 3 | A | A | A | A | A | A | 10 |
| 60 | 1KS21ME003 | HEMANTH H | A | A | A | 1 | 2 | 3 | 1 | 2 | 3 | 1 | 2 | 3 | 1 | 2 | 3 | 1 | 2 | 3 | 12 |
| 61 | 1KS21ME004 | K HARISH KUMAR | A | 1 | A | A | 2 | 3 | 1 | 2 | 3 | 1 | 2 | 3 | A | A | A | A | A | A | 9 |
| 62 | 1KS21ME005 | MANOJ T S | A | A | A | 1 | 2 | 3 | 1 | 2 | 3 | 1 | 2 | 3 | 1 | 2 | 3 | 1 | 2 | 3 | 12 |
| 63 | 1KS21ME006 | N EKANTH | 1 | 2 | 3 | 1 | 2 | A | 1 | 2 | 3 | 1 | 2 | 3 | 1 | A | A | A | A | A | 12 |
| 64 | 1KS21ME007 | NITIN KUMAR P | A | A | A | A | A | A | A | A | A | A | A | A | A | A | A | A | A | A | 12 |
| 65 | 1KS21ME008 | PAVAN K | 1 | 2 | 3 | 1 | 2 | 3 | 1 | 2 | 2 | 1 | 2 | 3 | 1 | 2 | 3 | 1 | 2 | 3 | 15 |
| 66 | 1KS21ME009 | PAVANKUMAR H | 1 | 2 | A | 1 | 2 | 3 | 1 | 2 | 3 | A | A | A | 1 | A | A | A | A | A | 9 |
| 67 | 1KS21ME010 | RAJESH KUMAR N G | 1 | 2 | 3 | 1 | 2 | 3 | 1 | 2 | 3 | 1 | 2 | 3 | A | A | A | A | A | A | 12 |
| 68 | 1KS21ME011 | ROHIT KUMAR S | A | 1 | A | 1 | 2 | 3 | 1 | 2 | 3 | 1 | 2 | 3 | A | A | A | A | A | A | 12 |
| No. of Students Absent | | | 15 | 14 | 18 | 12 | 12 | 13 | 10 | 10 | 10 | 10 | 10 | 10 | 25 | 25 | 25 | | | | |
| No. of Students Present | | | 52 | 53 | 49 | 55 | 55 | 54 | 58 | 58 | 58 | 58 | 58 | 58 | 43 | 43 | 43 | | | | |
| Signature of trainer/placement coordinator | | | P | B | P | P | P | P | P | P | P | P | P | P | P | P | P | P | P | P | P |



Departments of Training and Placements

Internship Program for 3rd Semester students_2022-2023

Glimpse of Activities conducted during internship program

Date: 11th – 15th October 2022



Batch 1: CSE – Session 2 (Day 1)



Batch 2: CSE – Session 3 (Day 2)



Batch 4: ECE – Session 1 (Day 3)



Batch 3: ECE – Session 3 (Day 4)



Batch 5: CSD – Session 3 (Day 5)



Batch 6: AIML & ME– Session 2 (Day 5)



Feedback form_INTERNSHIP_3rd SEM_Day 1_11-10-2022

167 responses

[Publish analytics](#)

Date

167 responses

Copy



Session

167 responses

Copy



TRAINER NAME

Copy

167 responses

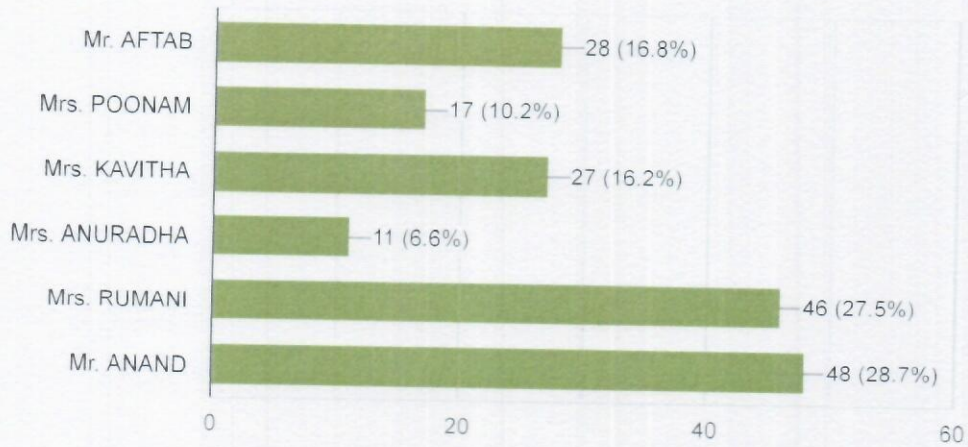

TOPICS COVERED

Copy

167 responses

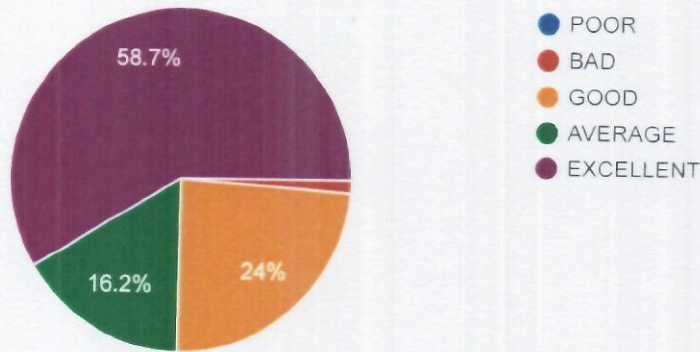

CONCEPTUAL CLARITY/ SUBJECT KNOWLEDGE

Copy

167 responses

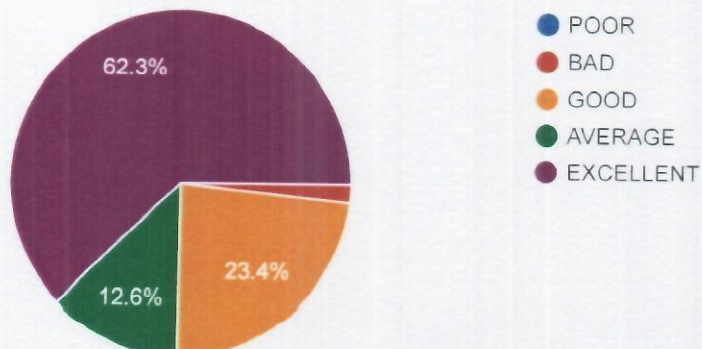

SOLVING DOUBTS/ INTERACTION

 Copy

167 responses

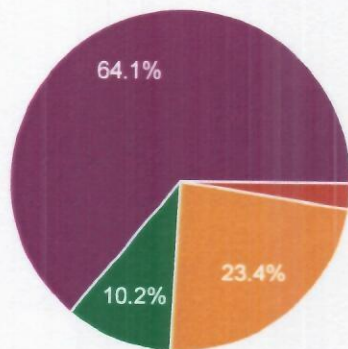

- POOR
- BAD
- GOOD
- AVERAGE
- EXCELLENT

TIME MANAGEMENT

 Copy

167 responses

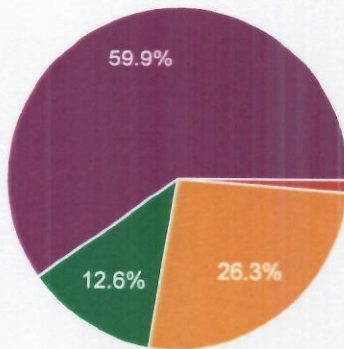

- POOR
- BAD
- GOOD
- AVERAGE
- EXCELLENT

OVERALL RATING

 Copy

167 responses

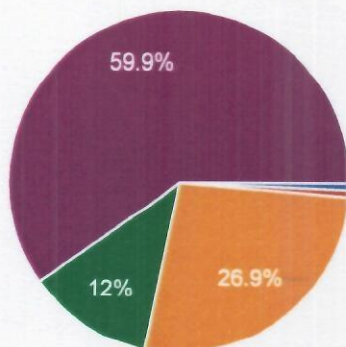

- POOR
- BAD
- GOOD
- AVERAGE
- EXCELLENT



Feedback form_INTERNSHIP_3rd SEM_Day 2_12-10-2022

150 responses

[Publish analytics](#)

Date

150 responses

Copy



Session

150 responses

Copy



TRAINER NAME

Copy

150 responses

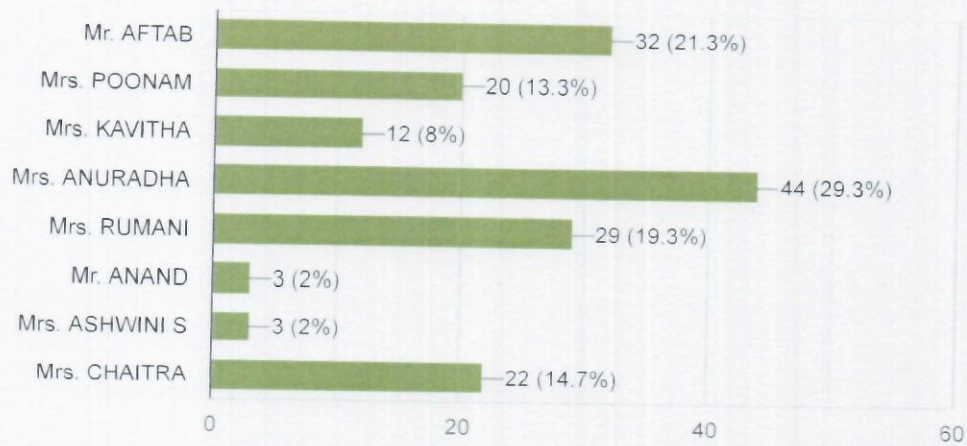

TOPICS COVERED

Copy

150 responses

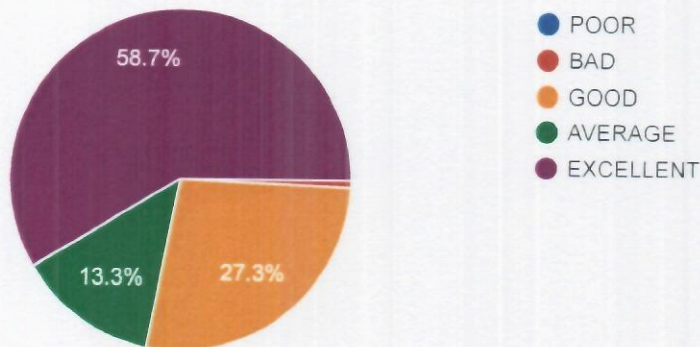

CONCEPTUAL CLARITY/ SUBJECT KNOWLEDGE

Copy

150 responses

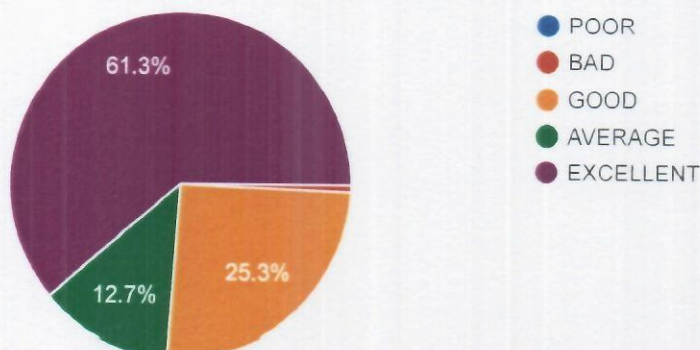

SOLVING DOUBTS/ INTERACTION

 Copy

150 responses

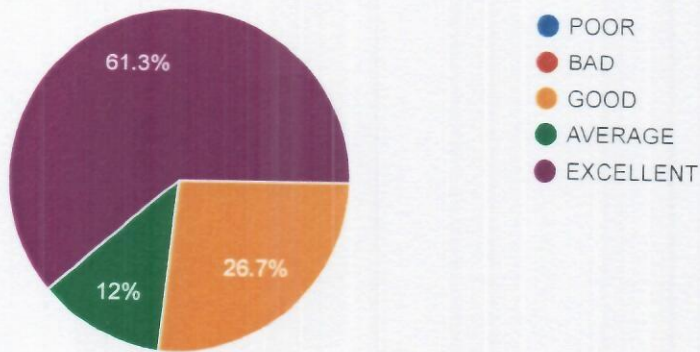

TIME MANAGEMENT

 Copy

150 responses

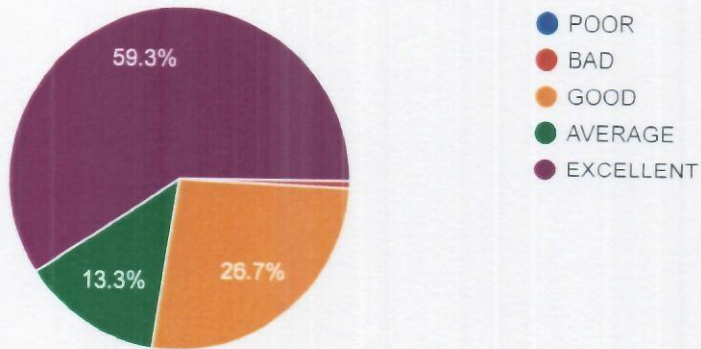

OVERALL RATING

 Copy

150 responses

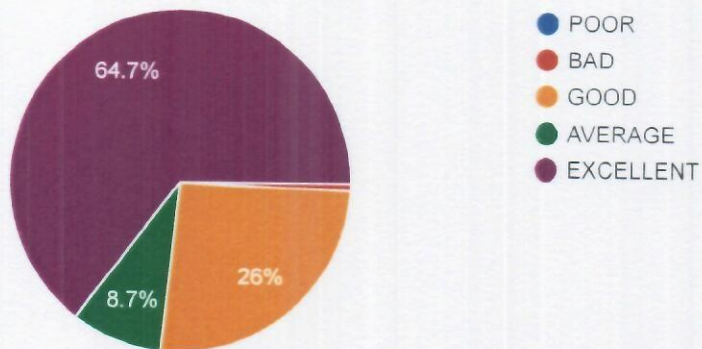



Feedback form_INTERNSHIP_3rd SEM_Day 3_13-10-2022

160 responses

[Publish analytics](#)

Date

160 responses

Copy



Session

160 responses

Copy

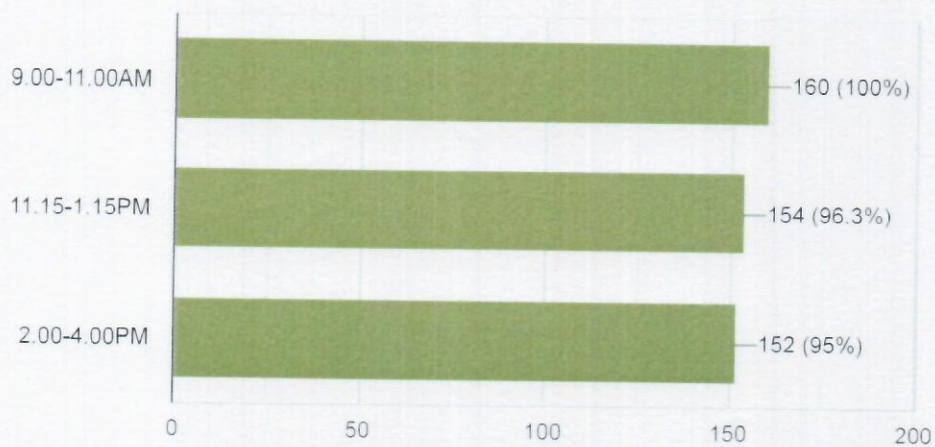

TRAINER NAME

Copy

160 responses



TOPICS COVERED

Copy

160 responses

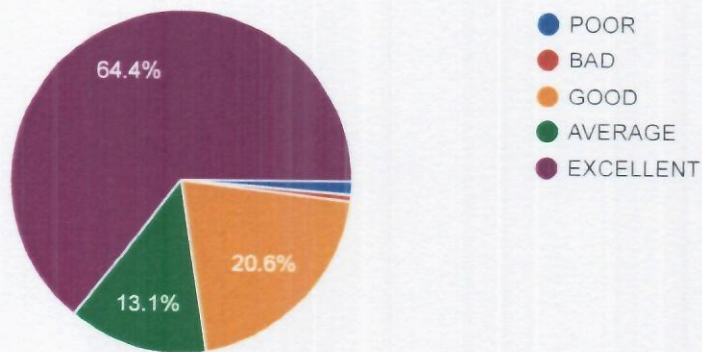

CONCEPTUAL CLARITY/ SUBJECT KNOWLEDGE

Copy

160 responses

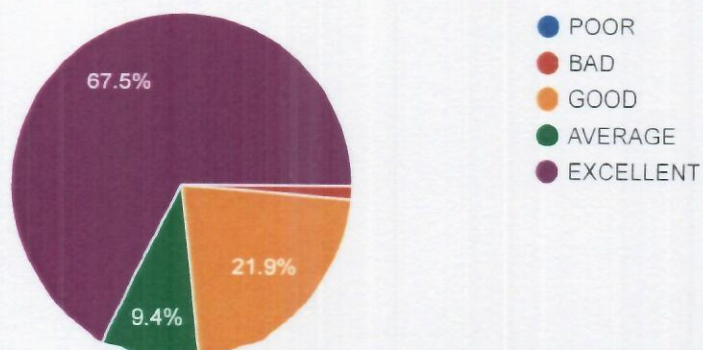

SOLVING DOUBTS/ INTERACTION

Copy

160 responses

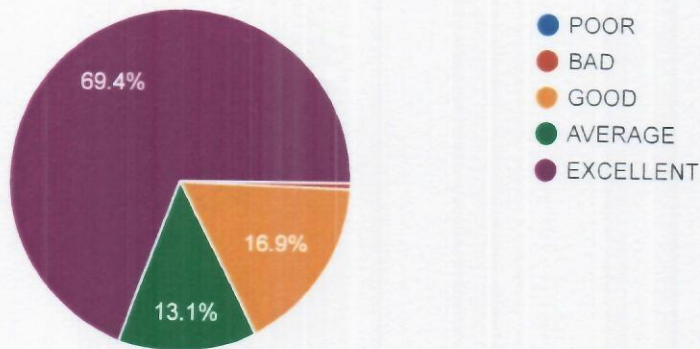

TIME MANAGEMENT

Copy

160 responses

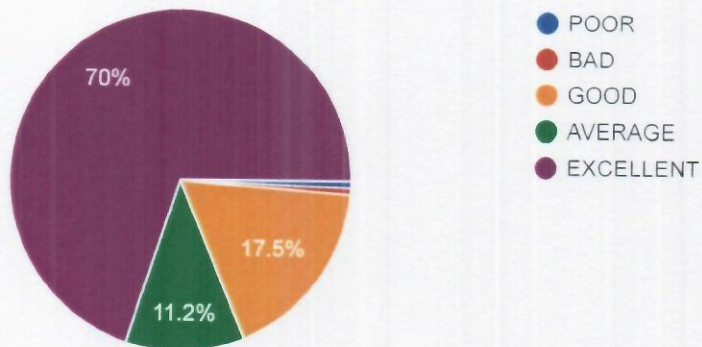

OVERALL RATING

Copy

160 responses

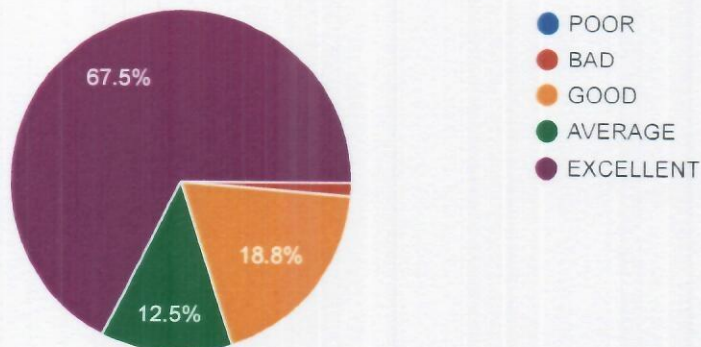



Feedback form_INTERNSHIP_3rd SEM_Day 4_14 - 10 - 2022

139 responses

[Publish analytics](#)

Date

139 responses

Copy



Session

139 responses

Copy

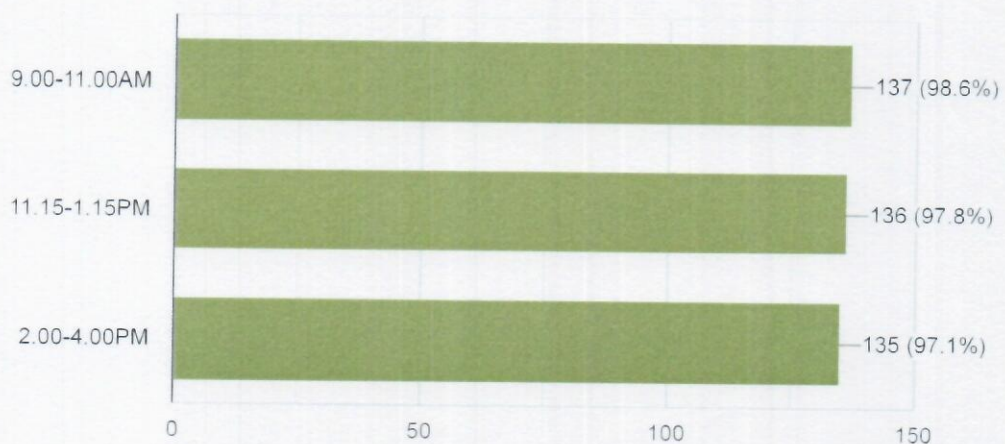

TRAINER NAME

Copy

139 responses

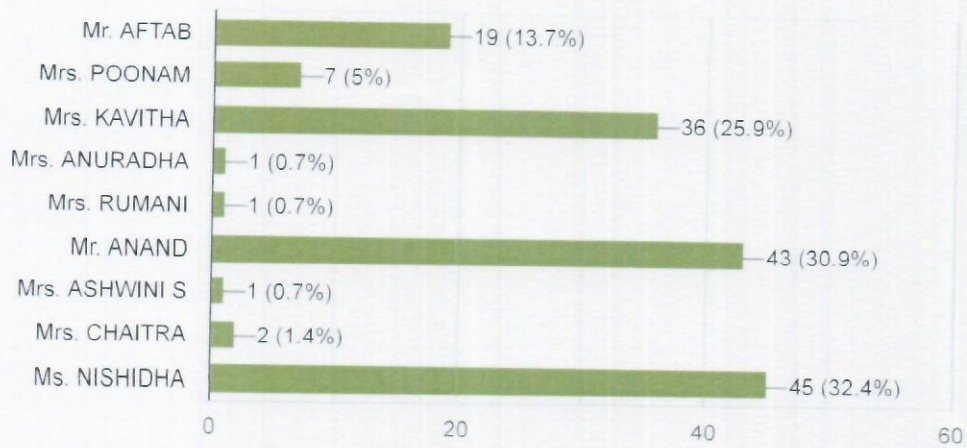

TOPICS COVERED

Copy

139 responses

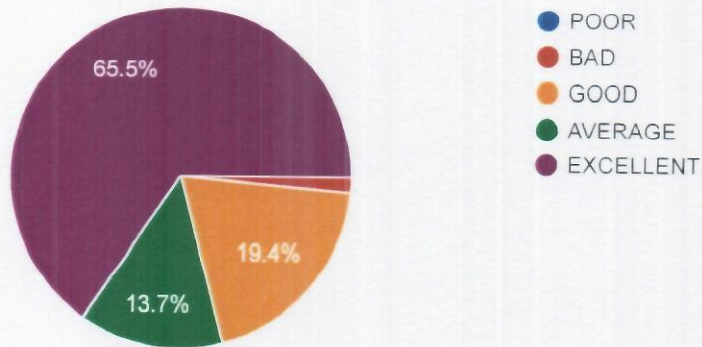

CONCEPTUAL CLARITY/ SUBJECT KNOWLEDGE

Copy

139 responses

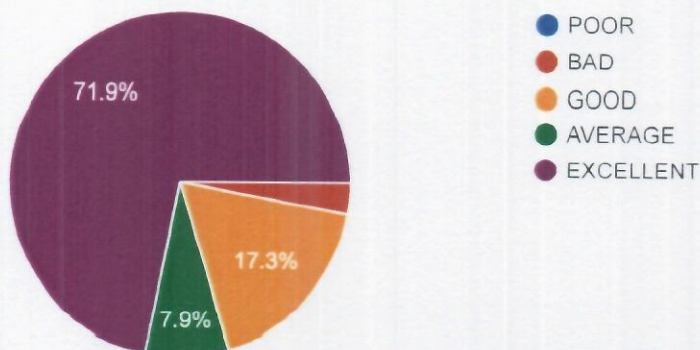

SOLVING DOUBTS/ INTERACTION

 Copy

139 responses

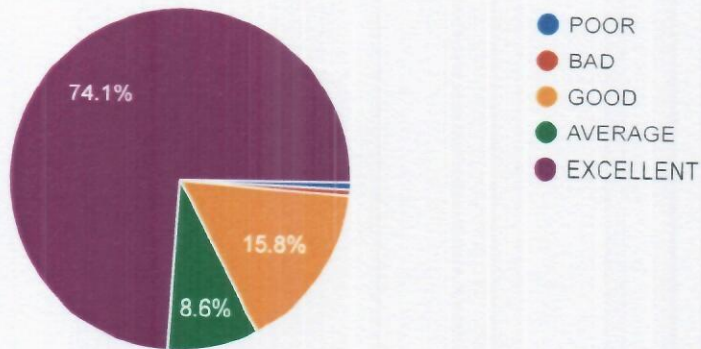

TIME MANAGEMENT

 Copy

139 responses

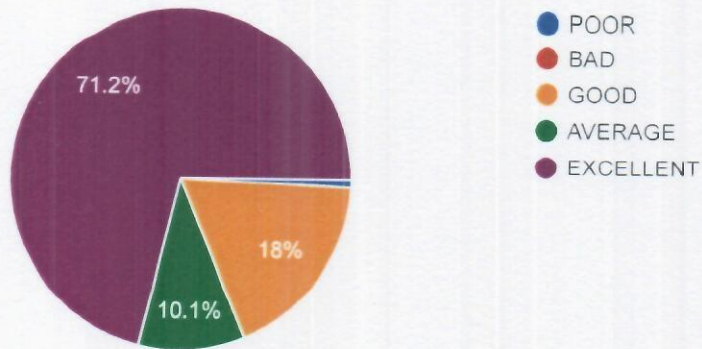

OVERALL RATING

 Copy

139 responses

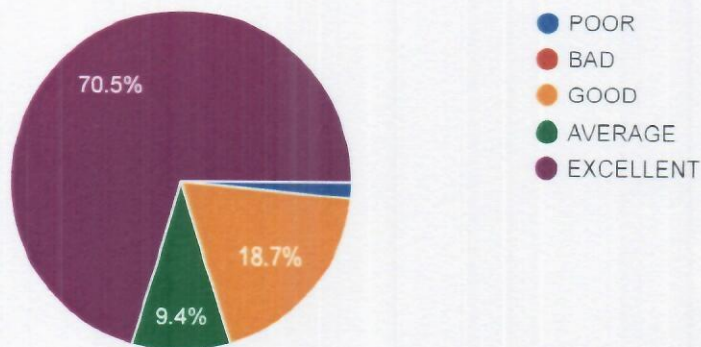

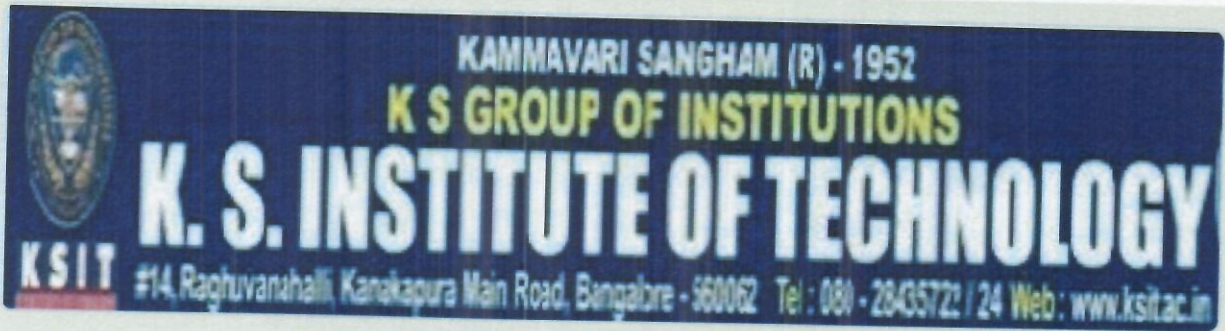

Feedback form_INTERNSHIP_3rd SEM_Day 5_15-10-2022

108 responses

[Publish analytics](#)

Date

108 responses

Copy

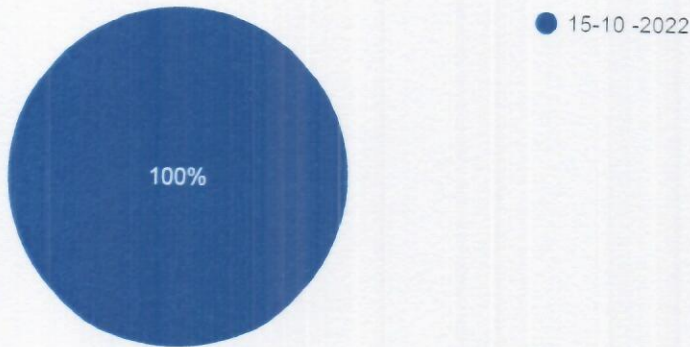

Session

108 responses

Copy

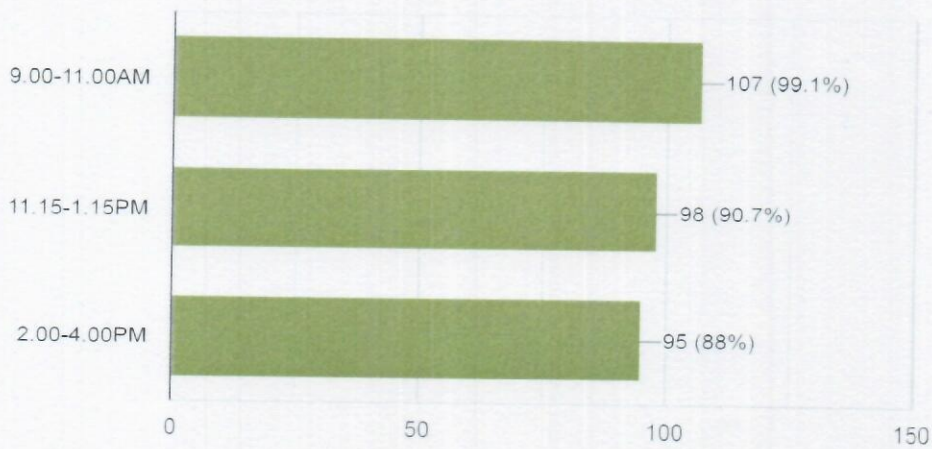

TRAINER NAME

Copy

108 responses

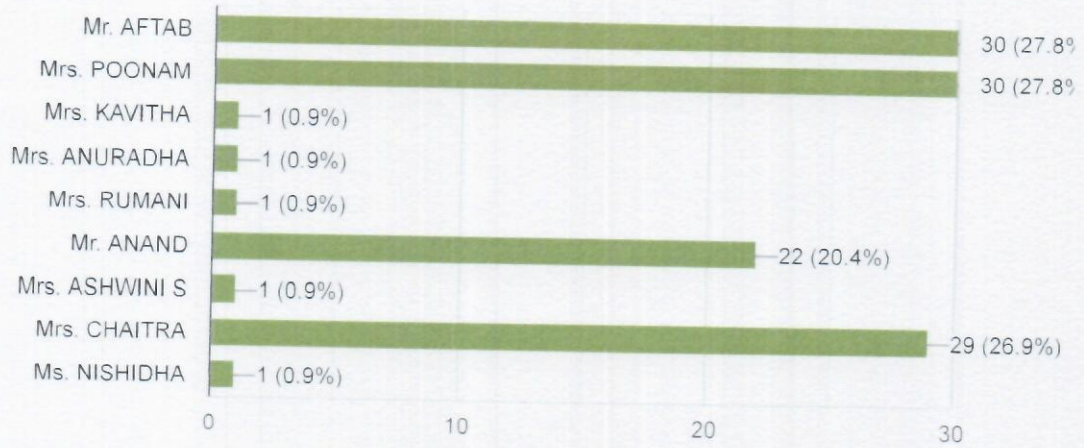

TOPICS COVERED

Copy

108 responses

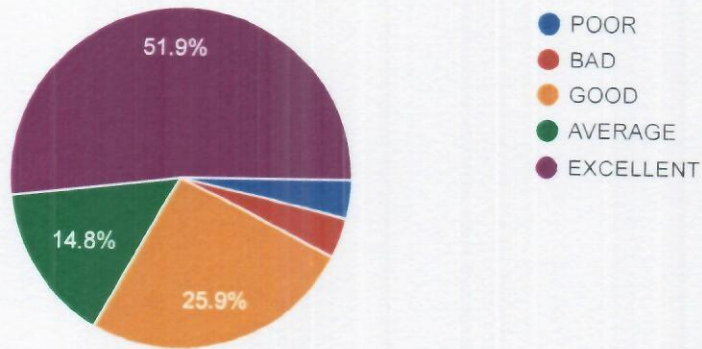

CONCEPTUAL CLARITY/ SUBJECT KNOWLEDGE

Copy

108 responses

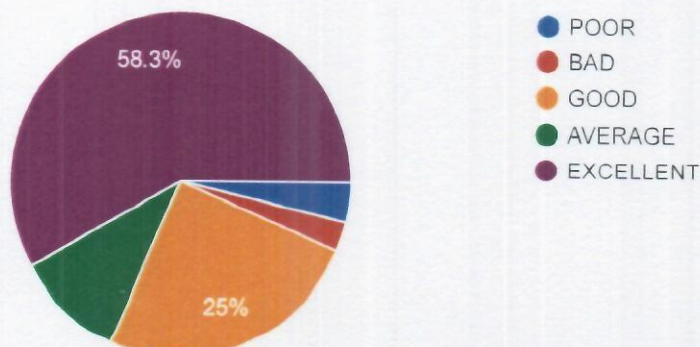

SOLVING DOUBTS/ INTERACTION

Copy

108 responses

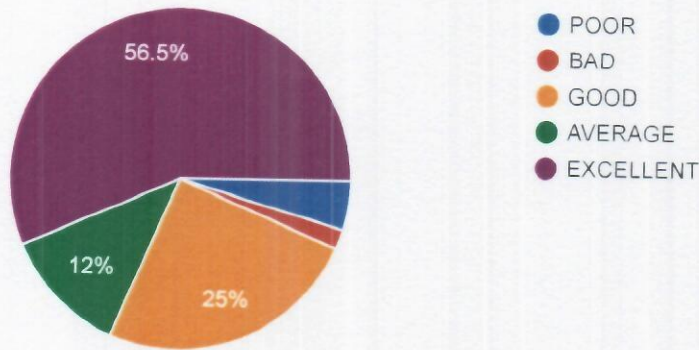

TIME MANAGEMENT

Copy

108 responses

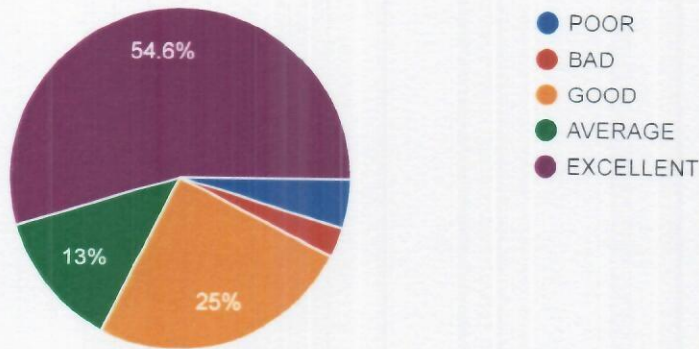

OVERALL RATING

Copy

108 responses

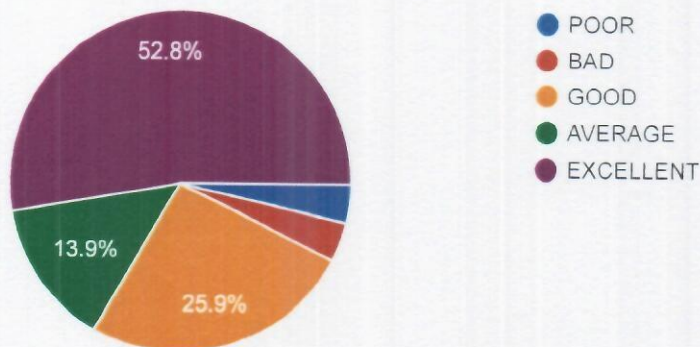

AXIS BANK LTD
JPNAGAR, 6TH PHASE, BANAGLORE [K, BENGALURU, 560078
IFS CODE - UTIB0001513

A/c Payee

VALID FOR THREE MONTHS FROM THE DATE OF ISSUE

DATE 24 08 2023
दिनांक D D M M Y Y Y Y

6347656
02/05/2023
SESHAASAI (M) / CTS - 2010

Pay **AUDAZ VENTURES PRIVATE LIMITED**

OR BEARER / या धारक को

रुपये Rupees **Two Lakh Twenty Three Thousand Six Hundred Twenty Four Only**

अदा करें

₹**2,23,624.00

A/C NO. 912010014093916

For K S INSTITUTE OF TECHNOLOGY

PLTRS 000160

[Signature]
Authorised Signatory(ies)

Please sign above

Payable at par at all branches of Axis Bank Ltd in India.

⑈ 241237⑈ 560211034⑈ 000160⑈ 31

Received on 28/8/23
[Signature]



KSIT
K.S. INSTITUTE OF TECHNOLOGY

Kammavari Sangham (R) 1952
K.S. GROUP OF INSTITUTIONS

ಕೆ.ಎಸ್. ತಾಂತ್ರಿಕ ಮಹಾವಿದ್ಯಾಲಯ

K.S. INSTITUTE OF TECHNOLOGY

Accredited By NAAC

14, Raghuvanahalli, Kanakapura Road, Bengaluru - 560 109.

Tel : 080 28435722 / 24, Fax : 080 28435723

E-mail : principal.ksit@gmail.com / principal@ksit.edu.in | website : www.ksit.edu.in

Ref: KSIT/PO/2022-2023/TPO 008

Date: 02/08/2023

To,
Audaz Ventures Private Limited
C-2 C-2/100, Janakpuri
South Wesy, Delhi-110058

Dear Sir,

Sub: Purchase Order for Soft Skills Training Program for 2nd year B.E Students.

With reference to the above, we are pleased to place the order for Soft Skills Training Program for 4th Semester Students at K.S.Institute of Technology, #14, Raghuvanahalli, Kanakapura Road, Bangalore – 109 as per the following specifications, terms & conditions.

Programme Commercials:

| Sl.No. | Description | Quantity | Rate | Amount |
|--------|--|----------|--|------------|
| 1 | Soft Skills Training Program for First Year B.E Students. | 406 | Rs. 17/Hour/Student 406 × 30Hrs × 17Rs) | 2,07,060/- |
| | Total | | | 2,07,060/- |
| | Taxable Value | | | |
| | ADD: (CGST 9% + SGST 9%) GST | | 18% | 37,270/- |
| | Grand TOTAL | | | 2,44,330/- |

Amount in Words: Rupees Two Lakhs Forty Four Thousand And Three Thirty Only.

Terms & Conditions:

- Training for 4th Semester students would be from 3rd-8th July 2023.
- Full Payment to be made post satisfactory completion of the training.

Thanking you,

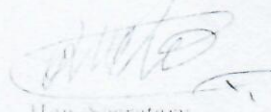
Hon. Secretary

KAMMAVARI SANGHAM

Audaz Ventures Private Limited

C-2-C-2/100, Janakpuri, South West Delhi-110058

AUDAZ

Email: info@audazlearning.com

PAN No. : AATCA6272A

GSTIN:

07AATCA6272A1ZN

Customer Details:

Name: K.S. Institute of Technology

Address: Bengaluru, Karnataka

Customer GSTIN: 29AAATK2287R1ZT

Invoice

Date

Place of Supply: Bengaluru, Karnataka

27/2023-24

14-Aug-23

Product-wise Details:

| Sr. No. | Description | SAC Code | Std Count | Training Duration (hrs) | Fees/std | Total Sale |
|---------|---|----------|-----------|-------------------------|----------|-------------|
| 1 | Internship Program for B.E. IV Semester | 9992 | 406 | 30 | 1700 | 2,07,060.00 |
| Total | | | | | | 2,07,060.00 |

Amount in Words:

INR Two Lakh Forty Four Thousand

Three Hundred Thirty only

Note: Make all cheques payable to Company Name.

Bank Name: HDFC

A/C Name: Audaz Ventures Pvt. Ltd.

A/C No.: 50200051099212

IFSC: HDFC0004876

| Sr. No. | CGST | | SGST | | IGST | |
|---------|--------|--------|--------|--------|--------|-----------|
| | Rate % | Amount | Rate % | Amount | Rate % | Amount |
| 1 | 0.00% | 0.00 | 0.00% | 0.00 | 18.00% | 37,270.80 |
| 2 | - | - | - | - | - | - |
| 3 | - | - | - | - | - | - |
| 4 | - | - | - | - | - | - |
| 5 | - | - | - | - | - | - |
| 6 | - | - | - | - | - | - |
| 7 | - | - | - | - | - | - |
| 8 | - | - | - | - | - | - |
| Total | | 0.00% | 0.00 | 0.00 | - | 37,270.80 |

Declaration:

We declare that this invoice shows the actual price of the services described and that all particulars are true and correct.



for Audaz Ventures Pvt. Ltd.

Authorised Signatory

| Summary | Amount |
|-------------------|-------------|
| Invoice Value | 2,07,060.00 |
| Total CGST (1) | - |
| Total SGST (2) | - |
| Total IGST (3) | 37,270.80 |
| Total GST (1+2+3) | 37,270.80 |
| Round-off | - |
| Grand Total | 2,44,330.80 |



Shrimal
18/8/23

K. Anand
18/8/23
CHIEF EXECUTIVE OFFICER
Member Secretary
Academic Advisory Board
K.S. Group of Institutions

[Signature]
22/08/23



K S GROUP OF INSTITUTIONS
DEPARTMENT OF TRAINING AND PLACEMENTS
COMPARATIVE STATEMENT OF TRAINING VENDORS

| Name of Training Agency | Trainer Profile and Rating | | | | | Training Cost / Student / Hour |
|--|----------------------------|---|------------------------------|-------------------------|-------------------------|--|
| | 1 Name | 2 Qualification | 3 Professional Experience | 4 Specialization | 5 Rating and Remarks | |
| AUDAZ | Asgar Pasha | B.Sc MBA HR | 18 years | Personality Development | 3+5 = 8 | AVG Score - 33/4 = 8.25 (Offline) = 20.5/Student/Hr + GST |
| | Belliapa | B.E. M.Tech | 30 year | Soft Skills | 4+5 = 9 | |
| | Parvathi | B.A.M.A. MBA HR | 18 years | Personality Development | 3+5 = 8 | |
| | Kavitha M | B.Sc (Physics, Maths & Electronics) M.sc (Maths) M.A. English | 20 years | Aptitude & Soft Skills | 3+5 = 8 | |
| Assessment Portal-Own portal available | | | | | 33 | |

III Sem (KSIT + KSSE)

17 + 02 = 19

| | | | | | | |
|----------------------------------|------------------------|-------------------|----------|------------------------|---------|--|
| BIZOTIC | SRINATH SETHURAMAN | M.Sc, MBA (UK) | 20 Years | Soft Skills and Verbal | 3+5 = 8 | AVG Score - 33/4 = 8.25 (Offline) = 20/Student/Hr + GST |
| | VINEET MANN | B.Sc, M.Sc | 15 Years | Aptitude | 3+5 = 8 | |
| | SHASHIKALA MADHUSUDHAN | LLB, M.Sc | 22 Years | Soft Skills and Verbal | 3+5 = 8 | |
| | K KRISHNA BAI | B.E, M.Tech (BSP) | 10 Years | Technical & Aptitude | 4+5 = 9 | |
| Assessment- Own Portal Available | | | | | 33 | |

IV Sem (KSIT + KSSE)

20 + 02 = 22

A. Gurus
12/10/20

| | | | | | | |
|----------------------------------|--------------|-----------------------------------|----------|-------------------------------|-----------|--|
| Quan Tech Origin | Deepak P.N. | B.E, M.E | 08 Years | English and Soft skills | 3+4 = 7 | AVG Score - 25/4 = 6.25 (Offline) = 20/Student/Hr + GST |
| | SAMUEL JOHN | Diploma (counselling skills), B.A | 12 Years | Communication and Soft Skills | 1+5 = 6 | |
| | Vignesh M.K. | B.E | 6 Years | Aptitude | 2+3 = 5 | |
| | Ananth P | B.E | 15 Years | Technical & Aptitude | 2 + 5 = 7 | |
| Assessment -Own Portal Available | | | | | 25 | |

+

| | | | | | | |
|--------------------------------------|--------------|-----------------|----------|----------------------------|---------|---|
| Transit | Beena N | B Sc, MS, PGDBA | 22 Years | Behaviour skills, Aptitude | 4+5 = 9 | AVG Score - 28/4 = 7 (Offline) = 23/Student/Hr + GST |
| | Sowmya Kerur | B E | 08 Years | Aptitude | 2+4 = 6 | |
| | AMIT MONDLE | | 20 Years | Personality Development | 2+3 = 5 | |
| | Arun Kumar | M.Sc, MBA | 17 Years | Technical & Aptitude | 3+5 = 8 | |
| Assessment - Still Under Development | | | | | 28 | |

MBA (I & II year)
19+38

| | | | | | | |
|--------------------------------------|-------------|--------------------------------------|----------|--|----------|--|
| Skill Factory | Raghavan | B.Com & MBA (HR) | 14 Years | Soft Skills and Verbal Skills | 3+5 = 8 | AVG Score - 33/4 = 8.25 ✓ (Offline) = 21/Student/Hr + GST |
| | Nisha | B.Com & MBA (Fin) | 10 Years | Logical, Analytical and Verbal | 3+5 = 8 | |
| | Dr. Jacob S | Ph.D | 14 Years | Placement oriented skills, verbal skills | 5+5 = 10 | |
| | Narasimha | B.E (Information Science) & MBA (HR) | 8 Years | Logical, Analytical and Verbal | 3+4 = 7 | |
| Assessment - Still Under Development | | | | | 33 | |

(KSIT + KSET)
VII Semester

| | | | | | | |
|--------------------------------------|----------------|-------------|----------|---------------------------------|---------|---|
| Universal Education | Avishek Ghosh | B Sc, MBA | 12 Years | Aptitude and Reasoning | 3+5 = 8 | AVG Score - 34/4 = 8.5 ✓ (Offline) = 22/Student/Hr + GST |
| | V Nandini Nair | B Sc, MBA | 12 Years | Verbal and communication skills | 3+5 = 8 | |
| | Ahinshu Ghosh | B E, MBA | 12 Years | Aptitude and Reasoning | 4+5 = 9 | |
| | Tapas Guha | B E, M.Tech | 12 Years | Technical Trainer | 4+5 = 9 | |
| Assessment - Still Under Development | | | | | 34 | |

20+case 18%

helps
MBA

| | | | | | | |
|-----------|-------------|---------------------|----------|---------------------------|-----------|--|
| JV Global | Darshan B V | B.E, Mtech | 6 Years | Quantitative & Analytical | 4 + 3 = 7 | AVG Score - 31/4 = 7.75 ✓ (Offline) = 25/Student/Hr + GST |
| | Bhargav A P | BA, MA | 10 Years | Soft skills | 4 + 4 = 8 | |
| | Beena N | B.Sc, PG, MS, PGDBA | 18 Years | Pre Placement Topics | 4 + 5 = 9 | |
| | Beena S | BE, Mtech | 6 Years | Quantitative & Analytical | 4 + 3 = 7 | |
| | | | | | 31 | |

| | | | | | | |
|----------------|----------------|------------|----------|---------------------------------|-----------|--|
| Pentagon Space | Yashwanth K N | BBM, MBA | 6 Years | Verbal and communication skills | 3 + 3 = 6 | AVG Score - 30/4 = 7.50 ✓ (Offline) = 32/Student/Hr + GST |
| | Hanu R | BE, M Tech | 08 Years | Technical Trainer | 4 + 4 = 8 | |
| | DASHRATH MISAL | B Com, MA | 15 Years | Soft skills and english | 3 + 5 = 8 | |
| | ARCHANA M S | B Com, MBA | 13 Years | Soft skills | 3 + 5 = 8 | |
| | | | | | 30 | |

Call the above for negotiations.

6/10/22

Chandru
06/10/22



K. S INSTITUTE OF TECHNOLOGY, BENGALURU-560109

14, Kanakapura Main Road, Raghuvanahalli, Bengaluru, Karnataka - 560109

** DEPARTMENT OF TRAINING AND PLACEMENTS **

Date: 25/07/2023

SOFT SKILLS TRAINING FOR 4th SEMESTER STUDENTS – 2025 BATCH

Placement Department has planned to conduct **Soft Skills Training Program** for 4th Semester students starting from 03/08/2023 to 08/08/2023 from 8.50 AM to 04.00 PM. All HOD's are hereby requested to communicate their Second-year students regarding the same.

The training will be conducted in OB-Classrooms. Batch wise details are shared below. All placement coordinators are requested to submit the consolidated **attendance of all 5 days** to Placement Department and to take the **feedback** for all the days. Department wise schedule is given below for your reference.

| Date | Time | Batch 1 | Batch 2 | Batch 3 | Batch 4 | Batch 5 | Batch 6 | Batch 7 |
|--|---------------------|-------------|---------|---------|---------|---------|---------|--|
| | | CSE | CSE | ECE | ECE | AIML | CSD | MECH+LATERAL ENTRIES FROM ALL BRANCHES |
| | | A | B | A | B | | | |
| | | Section | Section | Section | Section | | | |
| 3 rd 4 th 5 th 7 th 8 th AUGUST 2023 | 8.50 AM - 11.00 AM | LH 104 | LH 105 | LH 007 | LH 008 | LH 401 | LH 412 | LH 106 |
| | 11.00 AM - 11.15 AM | Break | | | | | | |
| | 11.15 AM - 1.15 PM | LH 104 | LH 105 | LH 007 | LH 008 | LH 401 | LH 412 | LH 106 |
| | 1.15 PM - 1.50 PM | Lunch Break | | | | | | |
| | 1.50 PM - 4.00 PM | LH 104 | LH 105 | LH 007 | LH 008 | LH 401 | LH 412 | LH 106 |

- All the students are informed to attend the session compulsorily in **Placement Dress code ONLY (Solid White Shirt and Black trousers)**.
- Students are strictly informed to be present in their allocated rooms only for all the five days. **DO NOT SWAP THE BATCHES.**
- Feedback QR code will be displayed in all the training rooms. **Students are informed to provide the feedback for each session before leaving the class.**
- Certificates will be given to those students who will have 100% attendance.



Shamas. C

PRINCIPAL
K.S. INSTITUTE OF TECHNOLOGY
BENGALURU - 560 109.

Cc to HOD's:

| | | | | |
|------------------------|------------------------|-------------------------|-------------------------|------------------------|
| CSE <i>[Signature]</i> | ECE <i>[Signature]</i> | MECH <i>[Signature]</i> | AIML <i>[Signature]</i> | CSD <i>[Signature]</i> |
|------------------------|------------------------|-------------------------|-------------------------|------------------------|



****DEPARTMENT OF TRAINING AND PLACEMENTS****

Date: 26/07/23

SOFT SKILLS TRAINING FOR 2ND AND 4TH SEMESTER STUDENTS

Dear all,

This is to inform you that Placement Department is conducting soft skills training for the 2nd and 4th semester students of KSIT, the students are required to attend the training sessions without fail.

If anybody is absent for any of the sessions, he/she is liable to pay a fine equivalent to the training cost.

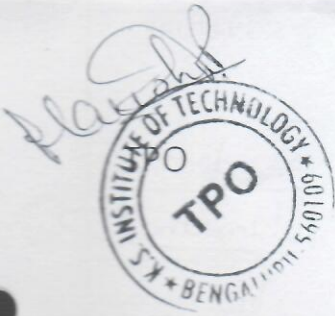

Sharma. V
PRINCIPAL
PRINCIPAL
K.S. INSTITUTE OF TECHNOLOGY
BENGALURU - 560 109.

CC TO:

HODs and Coordinators of:

| | | | | | |
|----------------------------|---------------------------|---------------------------|---------------------------|----------------------------|------------------------------|
| AIML <i>[Signature]</i> | CSE <i>[Signature]</i> | CSD <i>[Signature]</i> | ECE <i>[Signature]</i> | MECH <i>[Signature]</i> | AS & H <i>[Signature]</i> |
|----------------------------|---------------------------|---------------------------|---------------------------|----------------------------|------------------------------|



4TH SEM CLASS TEACHERS

| SL NO | BRANCH&SECTION | CLASS TEACHERS NAME | DATE | SIGNATURE |
|-------|----------------|---------------------|----------|------------|
| 1 | CSE-A | Abhilash L Bhal | 26/07/23 | Abhilash |
| 2 | CSE-B | Namyapriya D | 27/07/23 | Namyapriya |
| 3 | ECE-A | Bhanumathi A | 26/7/23 | Bhanumathi |
| 4 | ECE-B | Anita P | 26/7/23 | Anita |
| 5 | AIML | LAKSHMI KK | 26/7/23 | Lakshmi |
| 6 | CSD | SUSHMA A | 26/7/23 | Sushma |
| 7 | MECH | HARISH U | 27/7/23 | Harish |

2ND SEM CLASS TEACHERS

| SL NO | BRANCH & SECTION | CLASS TEACHER NAME | DATE | SIGNATURE |
|-------|------------------|--------------------|------------|-----------|
| 1 | CSE-A | Radhika N.P | 26/7/23 | Radhika |
| 2 | CSE-B | Mamatha N | 26/7/23 | Mamatha |
| 3 | CSE-C | SHYLAJA KR | 26/07/23 | Shylaja |
| 4 | CSD-D | Dr. Harisha S | 27/07/23 | Harisha |
| 5 | AMIL-E | Lekshmi C | 26/7/23 | Lekshmi |
| 6 | ECE-F | Kanya T N | 26/7/23 | Kanya |
| 7 | ECE-G | Dr. Reenuka C | 26/7/23 | Reenuka |
| 8 | IOT-H | Dr. Madhavi S | 26/07/2023 | Madhavi |
| 9 | CCE-I | Sneha G Kulkarni | 26/07/2023 | Sneha |
| 10 | MECH-J | TEJASWINI R | 26.07.23 | Tejaswini |

APTITUDE TRAINING REPORT FOR KSIT

| Date | Trainer's Name | Allotted Room | Duration | Topic Covered | Outcome |
|------------|----------------|---------------|----------|--|--|
| 03/08/2023 | Pruthvi | 007 | 6 Hrs | <ul style="list-style-type: none"> Averages | Clarity about the Concept And solving the problems on the given module |
| | Jamuna | 008 | | <ul style="list-style-type: none"> Problems on Age | |
| | Vikranth | 104 | | <ul style="list-style-type: none"> Speed, Distance and Time | |
| | Abhishek | 105 | | <ul style="list-style-type: none"> Boat Problems | |
| | Chethan | 106 | | <ul style="list-style-type: none"> Races | |
| | Suma | 401 | | <ul style="list-style-type: none"> Train Problem | |
| | Manohar | 412 | | | |
| 04/08/2023 | Abhishek | 007 | 6 Hrs | <ul style="list-style-type: none"> Profit and loss | Clarity about the Concept And solving the Logic and problems on Profit/Loss/Percentage questions and other |
| | Manohar | 008 | | <ul style="list-style-type: none"> Discount | |
| | Suma | 104 | | <ul style="list-style-type: none"> Number System | |
| | Vikranth | 105 | | <ul style="list-style-type: none"> Percentage | |
| | Prithvi | 106 | | | |
| | Jamuna | 401 | | <ul style="list-style-type: none"> Partnership | Modules |
| | Chethan | 412 | | | |

| Date | Trainer's Name | Allotted Room | Duration | Topic Covered | Outcome |
|------------|----------------|---------------|----------|--|---|
| 05/08/2023 | Abhishek | 007 | 6 Hrs | <ul style="list-style-type: none"> • Time and work- Individual | Understanding the concept behind the Problems and building IQ level by Solving it |
| | Vikranth | 008 | | <ul style="list-style-type: none"> • Time and Work – Group | |
| | Jamuna | 104 | | <ul style="list-style-type: none"> • Pipes and Cisterns | |
| | Suma | 105 | | <ul style="list-style-type: none"> • Permutation and Combinations | |
| | Chethan | 106 | | <ul style="list-style-type: none"> • Probability | |
| | Pruthvi | 401 | | <ul style="list-style-type: none"> • Progressions | |
| | Manohar | 412 | | | |
| 07/08/2023 | Vikrant | 007 | 6 Hrs | <ul style="list-style-type: none"> • Simple and Compound Interest | Clarity about the Concept And solving the problems on the given module |
| | Manohar | 008 | | <ul style="list-style-type: none"> • Ratio and Proportions | |
| | Prithvi | 104 | | <ul style="list-style-type: none"> • Allegations and mixtures | |
| | Jamuna | 105 | | <ul style="list-style-type: none"> • Data Sufficiency – 1 | |
| | Manish | 106 | | <ul style="list-style-type: none"> • Letter Series | |
| | Abhishek | 401 | | <ul style="list-style-type: none"> • Blood Relations | |
| | Chethan | 412 | | | |

| Date | Trainer's Name | Allotted Room | Duration | Topic Covered | Outcome |
|------------|----------------|---------------|----------|---|---|
| 08/08/2023 | Jamuna | 007 | 6 Hrs | <ul style="list-style-type: none">• Coding and decoding | Understanding the concept behind the Problems and building IQ level by Solving them |
| | Chethan | 008 | | <ul style="list-style-type: none">• Clocks | |
| | Abhishek | 104 | | <ul style="list-style-type: none">• Calendar | |
| | Prithvi | 105 | | <ul style="list-style-type: none">• Direction Sense | |
| | Manohar | 106 | | <ul style="list-style-type: none">• Seating Arrangement | |
| | Manish | 401 | | <ul style="list-style-type: none">• Syllogism | |
| | Vikrant | 412 | | | |

K S INSTITUTE OF TECHNOLOGY
DEPARTMENT OF TRAINING AND PLACEMENTS
CONSOLIDATED ATTENDANCE FOR SOFT SKILL TRAINING

| 2ND YEAR CSE-A | | | 4TH SEMESTER | | | | | | CSE-A(LH-104) | | | | | | | | |
|----------------|------------|----------------------------|--------------|---|---|------------|---|---|---------------|---|---|------------|----|----|------------|----|----|
| S. No | USN | NAME OF THE STUDENT | Dates | | | | | | | | | | | | | | |
| | | | 03/08/23 | | | 04/08/2023 | | | 05/08/2023 | | | 07/08/2023 | | | 08/08/2023 | | |
| | | | 1 | 2 | 3 | 4 | 5 | 6 | 7 | 8 | 9 | 10 | 11 | 12 | 13 | 14 | 15 |
| 1 | 1KS21CS001 | A RAMYASREE | P | P | P | P | P | P | P | P | P | P | P | P | P | P | P |
| 2 | 1KS21CS002 | AARYA M | P | P | P | P | P | P | P | P | P | P | A | A | P | P | P |
| 3 | 1KS21CS003 | ABHILASHA V | P | P | P | P | P | P | P | P | P | P | P | P | P | P | P |
| 4 | 1KS21CS004 | ABHIRAM K | P | P | P | P | P | P | P | P | A | P | P | P | P | P | P |
| 5 | 1KS21CS005 | ABHIRAM YADATORE SHANTARAM | P | P | P | P | P | P | P | P | P | P | P | P | P | P | P |
| 6 | 1KS21CS006 | ADITHI R | P | P | P | P | P | P | P | P | P | P | P | P | P | P | P |
| 7 | 1KS21CS007 | ADITHI S REDDY | P | P | P | P | P | P | P | P | P | P | P | P | P | P | P |
| 8 | 1KS21CS008 | ADITYA V | P | P | P | P | P | P | P | P | P | P | P | P | P | P | P |
| 9 | 1KS21CS009 | AFIFAH AYESHA BIJLI | P | P | P | P | P | P | P | P | P | P | P | P | P | P | P |
| 10 | 1KS21CS010 | AISHWARYA G | P | P | P | P | P | P | P | P | P | P | P | P | P | P | P |
| 11 | 1KS21CS011 | AKSHAY VIVEKANANDA B | P | P | P | P | P | P | P | P | P | P | A | A | A | A | A |
| 12 | 1KS21CS012 | ANANYA PRASAD S | P | P | P | P | P | P | P | P | P | P | P | P | P | P | P |
| 13 | 1KS21CS014 | ARCHANA P | P | P | P | P | P | P | P | P | P | P | P | P | P | P | P |
| 14 | 1KS21CS015 | ARTHAN M GOWDA | P | P | P | P | P | P | P | P | P | P | P | A | P | P | P |
| 15 | 1KS21CS016 | ASHA H P | P | P | P | P | P | P | P | P | P | P | P | P | P | P | P |
| 16 | 1KS21CS017 | ASHWINI | P | P | P | P | P | P | P | P | P | P | P | P | P | P | P |
| 17 | 1KS21CS018 | B G PRAJWAL | P | P | P | P | P | P | P | P | P | P | P | P | P | P | P |
| 18 | 1KS21CS020 | BHAVANA B | P | P | P | P | P | P | P | P | P | P | P | P | P | P | P |
| 19 | 1KS21CS021 | CHAITRA M | P | P | P | P | P | P | P | P | P | P | P | P | P | P | P |
| 20 | 1KS21CS022 | CHARISHMA A | P | P | P | P | P | P | P | P | P | P | P | P | P | P | P |
| 21 | 1KS21CS023 | CHARISHMA M | P | P | P | P | P | P | P | P | P | P | P | P | P | P | P |
| 22 | 1KS21CS024 | CETHAN H | P | P | P | P | P | P | P | P | P | A | A | A | P | P | P |
| 23 | 1KS21CS025 | DARSHAN S | P | P | P | P | P | P | P | P | P | P | P | P | P | P | P |
| 24 | 1KS21CS026 | DEEPTHI A B | A | A | A | P | P | P | P | P | P | P | P | P | P | P | P |
| 25 | 1KS21CS027 | DHRUTHI UMESH S | P | P | P | A | A | A | A | A | A | A | A | A | A | A | A |
| 26 | 1KS21CS028 | D L SHIVANG | P | P | P | P | P | P | P | P | P | P | P | P | P | P | P |
| 27 | 1KS21CS029 | GAANA S | P | P | P | P | P | P | P | P | P | A | A | A | A | A | A |
| 28 | 1KS21CS030 | GAGAN SHIVANNA | P | P | P | P | P | P | P | P | P | P | P | P | P | P | P |
| 29 | 1KS21CS031 | GOPALA KRISHNA V | P | P | P | P | P | P | P | P | P | A | A | A | A | A | A |
| 30 | 1KS21CS032 | GURUPRASAD Y S | P | P | P | P | P | P | P | P | P | P | P | P | P | P | P |
| 31 | 1KS21CS033 | HARSHITHA K M | P | P | P | P | P | P | P | P | P | P | P | P | P | P | P |
| 32 | 1KS21CS034 | HARSHITHA P | P | P | P | P | P | P | P | P | P | P | P | P | P | P | P |
| 33 | 1KS21CS035 | HARSHITHA R | P | P | P | P | P | P | A | P | P | P | P | P | P | P | P |
| 34 | 1KS21CS036 | HARSHITHA S | P | P | P | P | P | P | P | P | P | P | P | P | P | P | P |
| 35 | 1KS21CS037 | HARSHITHA S | P | P | P | P | P | P | P | P | P | P | P | P | P | P | P |
| 36 | 1KS21CS038 | HEMANTH KUMAR V | P | P | P | P | P | P | P | P | P | P | A | P | P | P | P |
| 37 | 1KS21CS039 | HRITHIKA V | P | P | P | P | P | P | P | P | P | P | P | P | P | P | P |
| 38 | 1KS21CS040 | IBBANI V GOWDA | P | P | P | P | P | P | P | P | P | P | P | P | P | P | P |
| 39 | 1KS21CS041 | IMAN GHORAI | P | P | P | P | P | P | P | A | P | P | P | P | P | P | P |
| 40 | 1KS21CS042 | JAHNAVI P | P | P | P | P | P | P | P | P | P | P | P | P | P | P | P |
| 41 | 1KS21CS043 | JASHWANTH P C | P | P | P | P | P | P | P | P | P | P | P | P | P | P | P |
| 42 | 1KS21CS045 | KANISHK E R | P | P | P | P | P | P | P | A | P | P | P | P | P | P | P |
| 43 | 1KS21CS046 | KARTHIK H N | P | P | P | P | P | P | P | P | P | P | P | P | P | P | P |
| 44 | 1KS21CS047 | KAUSHIK G V | P | P | P | P | P | P | P | P | P | P | P | P | P | P | P |
| 45 | 1KS21CS048 | KAVANA N | P | P | P | P | P | P | P | P | P | P | P | P | P | P | P |
| 46 | 1KS21CS049 | KAVYA B SINGH | P | P | P | P | P | P | P | P | P | P | P | P | P | P | P |
| 47 | 1KS21CS050 | KEERTHIKA S | P | P | P | P | P | P | P | P | P | P | P | P | P | P | P |
| 48 | 1KS21CS051 | KONGARA SREE SAI | A | P | P | P | P | P | P | P | P | P | P | P | A | P | P |

| K S INSTITUTE OF TECHNOLOGY | | | | | | | | | | | | | | | | | |
|---|------------|---------------------|--------------|---|---|------------|---|---|---------------|---|---|------------|----|----|------------|----|----|
| DEPARTMENT OF TRAINING AND PLACEMENTS | | | | | | | | | | | | | | | | | |
| CONSOLIDATED ATTENDANCE FOR SOFT SKILL TRAINING | | | | | | | | | | | | | | | | | |
| 2ND YEAR AIML | | | 4TH SEMESTER | | | | | | AIML (LH-104) | | | | | | | | |
| S. No | USN | NAME OF THE STUDENT | Dates | | | | | | | | | | | | | | |
| | | | 03/08/23 | | | 04/08/2023 | | | 05/08/2023 | | | 07/08/2023 | | | 08/08/2023 | | |
| | | | 1 | 2 | 3 | 4 | 5 | 6 | 7 | 8 | 9 | 10 | 11 | 12 | 13 | 14 | 15 |
| 1 | 1KS20AI024 | MOHAMMED ZEESHAN | A | A | A | A | A | A | 1 | 2 | 3 | 4 | 5 | 6 | 7 | 8 | 9 |
| 2 | 1KS20AI029 | PAVAN A | A | A | A | A | A | 1 | 2 | 3 | 4 | 5 | 6 | 7 | 8 | 9 | 10 |
| 3 | 1KS20AI040 | SYED AASIM HUBAIRA | 1 | 2 | 3 | 4 | 5 | 6 | 7 | 8 | 9 | 10 | 11 | 12 | 13 | 14 | 15 |
| 4 | 1KS21AI001 | ABHAY SURYA E | A | A | A | 1 | 2 | 3 | 4 | 5 | 6 | 7 | 8 | 9 | 10 | 11 | 12 |
| 5 | 1KS21AI002 | ADITHI R | 1 | 2 | 3 | 4 | 5 | 6 | 7 | 8 | 9 | 10 | 11 | 12 | 13 | 14 | 15 |
| 6 | 1KS21AI003 | ADITYA KALKUR | 1 | 2 | 3 | 4 | 5 | 6 | 7 | 8 | 9 | 10 | 11 | 12 | 13 | 14 | 15 |
| 7 | 1KS21AI004 | AMRUTHA M V | 1 | 2 | 3 | 4 | 5 | 6 | 7 | 8 | 9 | 10 | 11 | 12 | 13 | 14 | 15 |
| 8 | 1KS21AI005 | ANANYA B GOWDA | 1 | 2 | 3 | 4 | 5 | 6 | 7 | 8 | A | 9 | 10 | 11 | 12 | 13 | 14 |
| 9 | 1KS21AI006 | ANANYA PRAMOD | 1 | 2 | 3 | 4 | 5 | 6 | 7 | 8 | 9 | A | 10 | 11 | 12 | 13 | 14 |
| 10 | 1KS21AI007 | ANUSHREE R | 1 | 2 | 3 | 4 | 5 | 6 | 7 | 8 | 9 | 10 | 11 | 12 | 13 | 14 | 15 |
| 11 | 1KS21AI008 | APEKSHA I M | 1 | 2 | 3 | 4 | 5 | 6 | 7 | 8 | 9 | 10 | 11 | 12 | 13 | 14 | 15 |
| 12 | 1KS21AI009 | ARVIND N | 1 | 2 | 3 | 4 | 5 | 6 | 7 | 8 | 9 | 10 | 11 | 12 | 13 | 14 | 15 |
| 13 | 1KS21AI010 | BHUVAN S GOWDA | 1 | 2 | 3 | A | 4 | 5 | 6 | 7 | 8 | 9 | 10 | 11 | 12 | 13 | 14 |
| 14 | 1KS21AI011 | CHAITRA S | 1 | 2 | 3 | 4 | 5 | 6 | 7 | 8 | 9 | 10 | 11 | 12 | 13 | 14 | 15 |
| 15 | 1KS21AI012 | CHEZHAN S | 1 | 2 | 3 | 4 | 5 | 6 | 7 | 8 | 9 | 10 | 11 | 12 | 13 | 14 | 15 |
| 16 | 1KS21AI013 | CHIRAG V S | 1 | 2 | 3 | 4 | 5 | 6 | 7 | A | 8 | 9 | 10 | 11 | 12 | 13 | 14 |
| 17 | 1KS21AI014 | ESHWAR S | 1 | 2 | 3 | 4 | 5 | 6 | 7 | 8 | 9 | A | 10 | 11 | 12 | 13 | 14 |
| 18 | 1KS21AI015 | G C SAMBRAM | 1 | 2 | 3 | 4 | 5 | 6 | 7 | 8 | 9 | 10 | 11 | 12 | 13 | 14 | 15 |
| 19 | 1KS21AI016 | G VINAY KUMAR | 1 | 2 | 3 | 4 | 5 | 6 | 7 | 8 | 9 | 10 | 11 | 12 | 13 | 14 | 15 |
| 20 | 1KS21AI017 | HARIKRISHNA G | 1 | 2 | 3 | 4 | 5 | 6 | 7 | 8 | 9 | 10 | 11 | 12 | 13 | 14 | 15 |
| 21 | 1KS21AI018 | HARSHITHA A | 1 | 2 | 3 | 4 | 5 | 6 | 7 | 8 | 9 | 10 | 11 | 12 | 13 | 14 | 15 |
| 22 | 1KS21AI019 | HEMALATHA D R | 1 | 2 | 3 | 4 | 5 | 6 | 7 | 8 | 9 | 10 | 11 | 12 | 13 | 14 | 15 |
| 23 | 1KS21AI020 | JAYASHREE P R | 1 | 2 | 3 | 4 | 5 | 6 | 7 | 8 | 9 | 10 | 11 | 12 | 13 | 14 | 15 |
| 24 | 1KS21AI021 | K J ARUN | 1 | 2 | 3 | 4 | 5 | 6 | 7 | 8 | 9 | 10 | 11 | 12 | 13 | 14 | 15 |
| 25 | 1KS21AI022 | KARTHIK CHAVAN | 1 | 2 | 3 | 4 | 5 | 6 | 7 | 8 | 9 | 10 | 11 | 12 | 13 | 14 | 15 |
| 26 | 1KS21AI023 | KAVYA S | 1 | 2 | 3 | 4 | 5 | 6 | 7 | 8 | 9 | 10 | 11 | 12 | 13 | 14 | 15 |
| 27 | 1KS21AI024 | KEERTHANA R | 1 | 2 | 3 | 4 | 5 | 6 | 7 | 8 | 9 | 10 | 11 | 12 | 13 | 14 | 15 |
| 28 | 1KS21AI025 | LIKITHA K | 1 | 2 | 3 | 4 | 5 | 6 | 7 | 8 | 9 | A | A | A | 10 | 11 | 12 |
| 29 | 1KS21AI026 | LOCHAN K | 1 | 2 | 3 | 4 | 5 | 6 | 7 | 8 | 9 | 10 | 11 | 12 | 13 | 14 | 15 |
| 30 | 1KS21AI027 | LOKARANJAN B S | 1 | 2 | 3 | 4 | 5 | 6 | 7 | 8 | 9 | 10 | 11 | 12 | 13 | 14 | 15 |
| 31 | 1KS21AI028 | MODUPALLI MEGHANA | A | 1 | 2 | 3 | A | A | 4 | 5 | 6 | 7 | 8 | 9 | A | A | A |
| 32 | 1KS21AI029 | MRUDULA S R | 1 | 2 | 3 | 4 | 5 | 6 | 7 | 8 | 9 | 10 | 11 | 12 | 13 | 14 | 15 |
| 33 | 1KS21AI030 | NABIHA SHARIFF | 1 | 2 | 3 | 4 | 5 | 6 | 7 | 8 | 9 | 10 | 11 | 12 | 13 | 14 | 15 |
| 34 | 1KS21AI031 | NEERAJ P | A | A | A | 1 | 2 | 3 | 4 | 5 | 6 | 7 | 8 | 9 | 10 | 11 | 12 |
| 35 | 1KS21AI032 | NEHA K B | 1 | 2 | 3 | 4 | 5 | 6 | 7 | 8 | 9 | 10 | 11 | 12 | 13 | 14 | 15 |

K S INSTITUTE OF TECHNOLOGY

DEPARTMENT OF TRAINING AND PLACEMENTS

CONSOLIDATED ATTENDANCE FOR SOFT SKILL TRAINING

| 2ND YEAR -CSD | | | 4TH SEMESTER | | | | | | | CSD-(LH-412) | | | | | | | |
|---------------|------------|--------------------------|--------------|---|---|------------|---|---|------------|--------------|---|------------|----|----|------------|----|----|
| S. No | USN | NAME OF THE STUDENT | Dates | | | | | | | | | | | | | | |
| | | | 03/08/23 | | | 04/08/2023 | | | 05/08/2023 | | | 07/08/2023 | | | 08/08/2023 | | |
| | | | 1 | 2 | 3 | 4 | 5 | 6 | 7 | 8 | 9 | 10 | 11 | 12 | 13 | 14 | 15 |
| 1 | IKS21CG001 | A S N SREEYA | 1 | 2 | 3 | 4 | 5 | 6 | 7 | 8 | 9 | 10 | 11 | 12 | 13 | 14 | 15 |
| 2 | IKS21CG002 | ABDUS SALAAM I | 1 | 2 | A | 4 | 5 | 6 | 7 | 8 | 9 | A | A | A | 10 | 11 | 12 |
| 3 | IKS21CG003 | ABHILASHA PATIL | 1 | 2 | 3 | 4 | 5 | 6 | 7 | 8 | 9 | 10 | 11 | 12 | 13 | 14 | 15 |
| 4 | IKS21CG004 | ANAGHA SHASTRY | 1 | 2 | 3 | 4 | 5 | 6 | 7 | 8 | 9 | 10 | 11 | 12 | 13 | 14 | 15 |
| 5 | IKS21CG005 | ANKITHA DEVLOKAM | 1 | 2 | 3 | 4 | 5 | 6 | 7 | 8 | 9 | 10 | 11 | 12 | 13 | 14 | 15 |
| 6 | IKS21CG006 | ARPITHA G R | 1 | 2 | 3 | 4 | 5 | 6 | 7 | 8 | 9 | 10 | 11 | 12 | 13 | 14 | 15 |
| 7 | IKS21CG007 | B H RUCHIRA | 1 | 2 | 3 | 4 | 5 | 6 | 7 | 8 | 9 | 10 | 11 | 12 | 13 | 14 | 15 |
| 8 | IKS21CG008 | BADARI PRASAD M | 1 | 2 | 3 | 4 | 5 | 6 | 7 | 8 | 9 | 10 | 11 | 12 | 13 | 14 | 15 |
| 9 | IKS21CG009 | BHARAT R | 1 | 2 | 3 | 4 | 5 | 6 | 7 | 8 | 9 | 10 | 11 | 12 | 13 | 14 | 15 |
| 10 | IKS21CG011 | CHALLA DEEPIKA | 1 | 2 | 3 | 4 | 5 | 6 | 7 | 8 | 9 | 10 | 11 | 12 | 13 | 14 | 15 |
| 11 | IKS21CG012 | DANDA AJITH KUMAR | 1 | 2 | 3 | 4 | 5 | 6 | 7 | 8 | 9 | 10 | 11 | 12 | 13 | 14 | 15 |
| 12 | IKS21CG013 | DEEPIKA S | 1 | 2 | 3 | 4 | 5 | 6 | 7 | 8 | 9 | 10 | 11 | 12 | 13 | 14 | 15 |
| 13 | IKS21CG014 | DEEPTHI G B | 1 | 2 | 3 | 4 | 5 | 6 | 7 | 8 | 9 | 10 | 11 | 12 | 13 | 14 | 15 |
| 14 | IKS21CG015 | DHANUSH B K | 1 | 2 | 3 | 4 | 5 | 6 | 7 | 8 | 9 | 10 | 11 | 12 | 13 | 14 | 15 |
| 15 | IKS21CG016 | DIVYA T | 1 | 2 | 3 | 4 | 5 | 6 | A | A | A | 7 | 8 | 09 | 10 | 11 | 12 |
| 16 | IKS21CG017 | G PRADEEP | 1 | 2 | 3 | 4 | 5 | 6 | 7 | 8 | 9 | 10 | 11 | 12 | 13 | 14 | 15 |
| 17 | IKS21CG018 | G YOGIRAM | 1 | 2 | 3 | 4 | 5 | 6 | 7 | 8 | 9 | 10 | 11 | 12 | 13 | 14 | 15 |
| 18 | IKS21CG019 | GOVIND VENKATESHA SHETTY | 1 | 2 | 3 | 4 | 5 | 6 | 7 | 8 | 9 | 10 | 11 | 12 | 13 | 14 | 15 |
| 19 | IKS21CG020 | HEMANTH M | 1 | 2 | 3 | 4 | 5 | 6 | 7 | 8 | 9 | 10 | 11 | 12 | 13 | 14 | 15 |
| 20 | IKS21CG021 | KARTHIK C S | 1 | 2 | 3 | 4 | 5 | 6 | 7 | 8 | 9 | 10 | 11 | 12 | 13 | 14 | 15 |
| 21 | IKS21CG022 | KEERTHANA LOKESH | 1 | 2 | 3 | 4 | 5 | 6 | 7 | 8 | 9 | 10 | 11 | 12 | 13 | 14 | 15 |
| 22 | IKS21CG023 | KEERTHANA S | 1 | 2 | 3 | 4 | 5 | 6 | 7 | 8 | 9 | 10 | 11 | 12 | 13 | 14 | 15 |
| 23 | IKS21CG024 | KEERTHANA S D | 1 | 2 | 3 | 4 | 5 | 6 | 7 | 8 | 9 | 10 | 11 | 12 | 13 | 14 | 15 |
| 24 | IKS21CG025 | KUSHAL M J | 1 | 2 | 3 | 4 | 5 | 6 | 7 | 8 | 9 | 10 | 11 | 12 | 13 | 14 | 15 |
| 25 | IKS21CG026 | KUSUM PAKIRA | 1 | 2 | 3 | 4 | 5 | 6 | 7 | 8 | 9 | 10 | 11 | 12 | 13 | 14 | 15 |
| 26 | IKS21CG027 | MONISHA M | | | | | | | | | | | | | | | |
| 27 | IKS21CG028 | NEHA M R | 1 | 2 | 3 | 4 | 5 | 6 | 7 | 8 | 9 | 10 | 11 | 12 | 13 | 14 | 15 |
| 28 | IKS21CG029 | NISHANTH G K | A | A | A | 1 | 2 | 3 | 4 | 5 | 6 | 7 | 8 | 9 | 10 | 11 | 12 |
| 29 | IKS21CG030 | PAVITHRAA G | 1 | 2 | 3 | 4 | 5 | 6 | 7 | 8 | 9 | 10 | 11 | 12 | 13 | 14 | 15 |
| 30 | IKS21CG031 | PRATEEK C HIEMATH | 1 | 2 | 3 | 4 | 5 | 6 | 7 | 8 | 9 | 10 | 11 | 12 | 13 | 14 | 15 |
| 31 | IKS21CG032 | PREETHAM H V | 1 | 2 | 3 | 4 | 5 | 6 | 7 | 8 | 9 | 10 | 11 | 12 | 13 | 14 | 15 |
| 32 | IKS21CG033 | RAYALA SAI PRAKASH | 1 | 2 | 3 | 4 | 5 | 6 | 7 | 8 | 9 | 10 | 11 | 12 | 13 | 14 | 15 |
| 33 | IKS21CG034 | RIYA NAIR | 1 | 2 | 3 | 4 | 5 | 6 | 7 | 8 | 9 | 10 | 11 | 12 | 13 | 14 | 15 |
| 34 | IKS21CG035 | SANJANA SREENIVAS | 1 | 2 | 3 | 4 | 5 | 6 | 7 | 8 | 9 | 10 | 11 | 12 | A | A | A |
| 35 | IKS21CG036 | SANJANA V | 1 | 2 | 3 | 4 | 5 | 6 | 7 | 8 | 9 | 10 | 11 | 12 | 13 | 14 | 15 |
| 36 | IKS21CG037 | SANJAY P | 1 | 2 | 3 | 4 | 5 | 6 | 7 | 8 | 9 | 10 | 11 | 12 | 13 | 14 | 15 |
| 37 | IKS21CG038 | SATHYA SAI SRI B S | 1 | 2 | 3 | 4 | 5 | 6 | 7 | 8 | 9 | 10 | 11 | 12 | 13 | 14 | 15 |
| 38 | IKS21CG039 | SAVYASHREE S | 1 | 2 | 3 | 4 | 5 | 6 | 7 | 8 | 9 | 10 | 11 | 12 | 13 | 14 | 15 |
| 39 | IKS21CG040 | SHALINI B | 1 | 2 | 3 | 4 | 5 | 6 | 7 | 8 | 9 | 10 | 11 | 12 | 13 | 14 | 15 |

| SL NO | USN | NAME OF THE STUDENT | 1 | 2 | 3 | 4 | 5 | 6 | 7 | 8 | 9 | 10 | 11 | 12 | 13 | 14 | 15 |
|-----------------------------|------------|-------------------------------|---|--------------------|--------------------|--------------------|--------------------|--------------------|--------------------|--------------------|--------------------|--------------------|--------------------|--------------------|--------------------|--------------------|--------------------|
| 32 | 1KS22CS414 | SOUNDARYA K S | P | P | P | P | P | P | P | P | P | P | P | P | P | P | P |
| 33 | 1KS22CS415 | SPANDANA M | P | P | P | P | P | P | P | P | P | P | P | P | P | P | P |
| 34 | 1KS22CS416 | VEDASHREE S | P | P | P | P | P | P | P | P | P | P | P | P | P | P | P |
| 35 | 1KS22EC400 | ADITHYA D | | A | P | P | P | P | P | P | P | P | P | P | P | P | P |
| 36 | 1KS22EC401 | APOORVA B | | P | P | P | P | P | P | P | P | P | P | P | P | P | P |
| 37 | 1KS22EC402 | B SREEPADREDDY H BULLANGOUDAR | | P | P | P | P | P | P | P | P | P | P | P | P | P | P |
| 38 | 1KS22EC403 | CHAITRA N | | P | P | P | P | P | P | P | P | P | P | P | P | P | P |
| 39 | 1KS22EC404 | GONUGUNTLA SHRUJANA | | P | P | P | P | P | P | P | P | P | P | P | P | P | P |
| 40 | 1KS22EC405 | HEMA K | | P | P | P | P | P | P | P | P | P | P | P | P | P | P |
| 41 | 1KS22EC406 | PAVANGOWDA H P | | P | P | P | P | P | P | P | P | P | P | P | P | P | P |
| 42 | 1KS22EC407 | PRAJWAL PATIL B.S | | P | P | P | P | P | P | P | P | P | P | P | P | P | A |
| 43 | 1KS22EC408 | SANGEETHA H M | | P | P | P | P | P | P | A | A | P | P | P | P | P | P |
| 44 | 1KS22EC409 | SOUNDARYA S | | P | P | P | P | P | P | P | P | P | P | P | P | P | P |
| 45 | 1KS22EC410 | SOWMYA A M | | P | P | P | P | P | P | P | P | P | P | P | P | P | P |
| 46 | 1KS22EC411 | SUDEEP P | | P | P | P | P | P | P | P | P | P | P | P | P | P | P |
| 47 | 1KS22EC412 | VAISHNAVI V | | P | P | P | P | P | P | P | P | P | P | A | A | A | A |
| 48 | 1KS22AI400 | AVINASH P | | P | P | P | P | P | P | P | P | P | P | P | P | P | P |
| 49 | 1KS22AI401 | CETHAN N | | P | P | P | P | P | P | P | P | P | P | P | P | P | P |
| 50 | 1KS22AI402 | K JAHNAVI | | P | P | P | P | P | P | P | P | P | P | P | P | P | P |
| 51 | 1KS22AI403 | RISHI S | | P | P | P | P | P | P | P | P | P | P | P | P | P | P |
| 52 | 1KS22AI404 | SAHU DURGAMADHAB SARATKUMAR | | P | P | P | P | P | A | A | A | P | P | P | A | A | A |
| 53 | 1KS22AI405 | SANJAY K U | | P | P | P | P | P | P | P | P | P | P | P | P | P | P |
| 54 | 1KS22AI406 | ULLAS B | | P | P | P | P | P | P | P | P | A | A | A | A | A | A |
| 55 | 1KS22CG400 | ARUN A | | P | P | P | P | P | P | P | P | P | P | P | P | P | P |
| 56 | 1KS22CG401 | CHANDRASEKAR A | | P | P | P | P | P | P | P | P | P | P | P | P | P | P |
| 57 | 1KS22CG402 | MAYURGANAPATI S BADGHRI | | P | P | P | P | P | P | P | P | P | P | P | P | P | P |
| 58 | 1KS22CG403 | NANDISH K S | | P | P | P | P | P | P | P | P | P | P | P | P | P | P |
| 59 | 1KS22CG404 | PURUSHOTHAM V MITTI | | P | P | P | P | P | P | P | P | P | P | P | P | P | P |
| 60 | 1KS22CG405 | PUTTUR PRAVEEN KUMAR | | P | P | P | P | P | P | P | P | P | P | P | P | P | P |
| 61 | 1KS22CG406 | SHARATH N | | P | P | P | P | P | P | P | P | P | P | P | P | P | P |
| 62 | 1KS22CG407 | SHRUTHI M | | P | P | P | P | P | P | P | P | P | P | P | P | P | P |
| 63 | 1KS22CG408 | SUSHIL WAGHAMARE | | P | P | P | P | P | P | P | P | P | P | P | P | P | P |
| NO OF STUDENTS ABSENT | | | | 01 | 02 | 01 | 01 | | 05 | 05 | 19 | 06 | 04 | 09 | 303 | 06 | 07 |
| NO OF STUDENTS PRESENT | | | | 62 | 61 | 62 | 62 | 58 | 58 | 58 | 44 | 57 | 59 | 54 | 60 | 57 | 56 |
| SIGNATURE OF CLASS TEACHERS | | | | <i>[Signature]</i> | <i>[Signature]</i> | <i>[Signature]</i> | <i>[Signature]</i> | <i>[Signature]</i> | <i>[Signature]</i> | <i>[Signature]</i> | <i>[Signature]</i> | <i>[Signature]</i> | <i>[Signature]</i> | <i>[Signature]</i> | <i>[Signature]</i> | <i>[Signature]</i> | <i>[Signature]</i> |

3
60
[Signature]



SESHAASAI/MI/CTS - 2010 15/10/2022 5487836



AXIS BANK LTD

JPNAGAR, 6TH PHASE, BANAGLORE [K], BENGALURU, 560078
IFS CODE - UTIB0001513

A/c. PAYEE ONLY

VALID FOR THREE MONTHS FROM THE DATE OF ISSUE

DATE

| | | | |
|----|----|----|----|
| 05 | 12 | 20 | 22 |
|----|----|----|----|

दिनांक D D M M Y Y Y Y

Pay Bizotic Edtech Pvt Ltd

OR BEARER / या धारक को

रुपये Rupees One lach eighty four thousand
82 hundred eighty only

अदा करें

₹ 1,84,680/-

A/C NO. 912010014093916

PLTRS 000160

For K S INSTITUTE OF TECHNOLOGY

Authorised Signatory(ies)
Please sign above

Payable at par at all branches of Axis Bank Ltd in India.

⑈ 229356⑈ 560211034⑈ 000160⑈ 31

Received on 8th Dec 2022



KSIT
K.S. INSTITUTE OF TECHNOLOGY

Kammavari Sangham (R) 1952
K.S. GROUP OF INSTITUTIONS

ಕೆ.ಎಸ್. ತಾಂತ್ರಿಕ ಮಹಾವಿದ್ಯಾಲಯ

K.S. INSTITUTE OF TECHNOLOGY

Accredited By NAAC

14, Raghuvanahalli, Kanakapura Road, Bengaluru - 560 109.

Tel : 080 28435722 / 24, Fax : 080 28435723

E-mail : principal.ksit@gmail.com / principal@ksit.edu.in | website : www.ksit.edu.in

Ref: KSIT/PO/2022-2023/TPO 007

Date: 10/11/2022

To,
Bizotic Edtech Private Ltd
#15, 3rd Main, 3rd Cross, Maruthi Nagar, Shreyas Colony
J.P Nagar 7th Phase, Bengaluru - 560078

Dear Sir,

Sub: Purchase Order for Personality Development Training Program for 5th Semester B.E Students.

With reference to the above, we are pleased to place the order for **Personality Development Training Program** for 5th Semester Students at **K.S. Institute of Technology**, #14, Raghuvanahalli, Kanakapura Road, Bangalore – 109 as per the following specifications, terms & conditions.

Programme Commercials:

| Sl.No. | Description | Quantity | Rate | Amount |
|---|---|----------|---|----------------------|
| 1 | Personality Development Training Program for 5 th BE Students | 285 | Rs. 20/Hour/Student (285 × 30Hrs × 20Rs) | 1,71,000/- |
| | Total | | | 1,71,000/- |
| | Taxable Value | | | 30,780/- |
| | ADD: CGST 9% | | | 15,390/- |
| | ADD: SGST 9% | | | 15,390/- |
| | Grand TOTAL | | | 2,01,780.00/- |
| <u>Amount in Words:</u> Rupees Two Lakh One Thousand and Seven Hundred Eight Only | | | | |

Terms & Conditions:

- Training for 5th Semester students would be from 17th – 23rd November 2022.
- Pre assessment test would be conducted on 16/11/2022 and post assessment test on 26/11/2022 at company portal only and report to be submitted on or before 28/11/2022.
- Full Payment to be made post satisfactory completion of the training.

Thanking you,

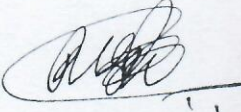
Hon. Secretary 30/11/22

KAMMAVARI SANGHAM

K.S. INSTITUTE OF TECHNOLOGY

Approved by AICTE, New Delhi & Affiliated to VTU, Belagavi, Karnataka



K S GROUP OF INSTITUTIONS
DEPARTMENT OF TRAINING AND PLACEMENTS
COMPARATIVE STATEMENT OF TRAINING VENDORS

| Name of Training Agency | Trainer Profile and Rating | | | | | Training Cost / Student / Hour |
|--|----------------------------|---|------------------------------|-------------------------|-------------------------|--|
| | 1 Name | 2 Qualification | 3 Professional Experience | 4 Specialization | 5 Rating and Remarks | |
| AUDAZ | Asgar Pasha | B.Sc MBA HR | 18 years | Personality Development | 3+5 = 8 | AVG Score - 33/4 = 8.25 ✓ (Offline) = 20.5/Student/Hr + GST |
| | Belliapa | B.E. M.Tech | 30 year | Soft Skills | 4+5 = 9 | |
| | Parvathi | B.A.M.A. MBA HR | 18 years | Personality Development | 3+5 = 8 | |
| | Kavitha M | B.Sc (Physics, Maths & Electronics) M.sc (Maths) | 20 years | Aptitude & Soft Skills | 3+5 = 8 | |
| Assessment Portal-Own portal available | | | | | 33 | |

III Sem (KSIT + KSSEM)

17 + 02 = 19

| | | | | | | |
|----------------------------------|------------------------|-------------------|----------|------------------------|---------|--|
| BIZOTIC | SRINATH SETHURAMAN | M.Sc, MBA (UK) | 20 Years | Soft Skills and Verbal | 3+5 = 8 | AVG Score - 33/4 = 8.25 ✓ (Offline) = 20/Student/Hr + GST |
| | VINEET MANN | B.Sc, M.Sc | 15 Years | Aptitude | 3+5 = 8 | |
| | SHASHIKALA MADHUSUDHAN | LLB, M.Sc | 22 Years | Soft Skills and Verbal | 3+5 = 8 | |
| | K KRISHNA BAI | B.E, M.Tech (BSP) | 10 Years | Technical & Aptitude | 4+5 = 9 | |
| Assessment- Own Portal Available | | | | | 33 | |

V Sem (KSIT + KSSEM)

20 + 02 = 22
K. Jagan 18/10/22

| | | | | | | |
|----------------------------------|--------------|------------------------------------|----------|-------------------------------|-----------|--|
| Quan Tech Origin | Deepak P.N. | B.E, M.E | 08 Years | English and Soft skills | 3+4 = 7 | AVG Score - 25/4 = 6.25 ✓ (Offline) = 20/Student/Hr + GST |
| | SAMUEL JOHN | Diploma (counselling skills), B. A | 12 Years | Communication and Soft Skills | 1+5 = 6 | |
| | Vignesh M.K. | B E | 6 Years | Aptitude | 2+3 = 5 | |
| | Ananth P | B E | 15 Years | Technical & Aptitude | 2 + 5 = 7 | |
| Assessment -Own Portal Available | | | | | 25 | |

+

| | | | | | | |
|-------------------------------------|----------------|---|----------|--|--------|---|
| Transt | Beena N | B.Sc, MS, PGDBA | 22 Years | Behaviour skills, Aptitude | 4+5=9 | AVG Score - 284 = 7 (Offline) = 23/Student/Hr + GST |
| | Sowmya Keer | B.E | 08 Years | Aptitude | 2+4=6 | |
| | AMIT MONDLE | | 20 Years | Personality Development | 2+3=5 | |
| | Aran Kumar | M.Sc, MBA | 17 Years | Technical & Aptitude | 3+5=8 | |
| Assessment -Skill Under Development | | | | | 28 | |
| Skill Factory | Raghavm | B.Com & MBA (HR) | 14 Years | Soft Skills and Verbal Skills | 3+5=8 | AVG Score - 334 = 8.25 (Offline) = 21/Student/Hr + GST |
| | Nicha | B.Com & MBA (Fin) | 10 Years | Logical, Analytical and Verbal | 3+5=8 | |
| | Dr. Jacob S | Ph.D | 14 Years | Placement oriented skills, verbal skills | 5+5=10 | |
| | Narasimha | B.E (INFORMATION Science) & MBA (HR) | 8 Years | Logical, Analytical and Verbal | 3+4=7 | |
| Assessment -Skill Under Development | | | | | 33 | |
| Universal Education | Avishek Ghosh | B.Sc, MBA | 12 Years | Aptitude and Reasoning | 3+5=8 | AVG Score - 344 = 8.5 (Offline) = 22/Student/Hr + GST |
| | V Nandini Nair | B.Sc, MBA | 12 Years | Verbal and communication skills | 3+5=8 | |
| | Ahmrut Ghosh | B.E, MBA | 12 Years | Aptitude and Reasoning | 4+5=9 | |
| | Tapas Guha | B.E, M.Tech | 12 Years | Technical Trainer | 4+5=9 | |
| Assessment -Skill Under Development | | | | | 34 | |
| JV Global | Darshan H V | B.E, Mech | 6 Years | Quantitative & Analytical | 4+3=7 | AVG Score - 314 = 7.75 (Offline) = 25/Student/Hr + GST |
| | Bhargav A P | BA, MA | 10 Years | Soft skills | 4+4=8 | |
| | Beena N | B.Sc, PG, MS, PGDBA | 18 Years | Pre Placement Topics | 4+5=9 | |
| | Beena S | BE, Mech | 6 Years | Quantitative & Analytical | 4+3=7 | |
| Assessment -Skill Under Development | | | | | 31 | |
| Postagon Space | Vaswandi E.N | BBA, MBA | 6 Years | Verbal and communication skills | 3+3=6 | AVG Score - 304 = 7.50 (Offline) = 32/Student/Hr + GST |
| | Hanu E | BE, M.Tech | 08 Years | Technical Trainer | 4+4=8 | |
| | DASHRATH MISAL | B.Com, MA | 15 Years | Soft skills and english | 3+5=8 | |
| | ARCHANA M.S | B.Com, MBA | 13 Years | Soft skills | 3+5=8 | |
| Assessment -Skill Under Development | | | | | 30 | |

MBA (I & II year)
19+GST

(KSIIT + KSEM)
VII Semester
20+case 18%
KSIIT
MIEHR

Call the above for negotiations.

20/10/22

checked
20/10/22



K.S INSTITUTE OF TECHNOLOGY

#14, Raghuvanahalli, Kanakapura Main Road, Bengaluru - 560109
Phone: 080-28435722/24 website: www.ksit.ac.in

** DEPARTMENT OF TRAINING AND PLACEMENTS **

15.11.2022

PERSONALITY DEVELOPMENT TRAINING PROGRAM FOR THIRD YEAR STUDENTS - 2024 BATCH

Placement department has planned to conduct **Personality Development Training Program** for 5th Semester students (All branches) from 17th to 23rd November 2022. All HOD's are hereby informed to communicate their third year students regarding the same.

The training will be conducted in old building class rooms. Batch wise details are shared below. All **placement coordinators** are requested to submit the consolidated attendance of all 5 days to placement department on or before 24th November 2022 without fail.

Department wise scheduled is given below for your reference.

| Date | Time | BATCH 1 | BATCH 2 | BATCH 3 | BATCH 4 | BATCH 5 |
|--|----------------------|-------------|----------|----------|----------|----------|
| | | CSE (A) | CSE (B) | ECE (A) | ECE (B) | AIML+ME |
| 17 th , 18 th , 21 st , 22 nd & 23 rd November 2022 | 8:50 AM - 11:00AM | OB - 007 | OB - 008 | OB - 104 | OB - 105 | OB - 106 |
| | 11:00AM - 11:15AM | BREAK | | | | |
| | 11:15 AM - 1:15PM | OB - 007 | OB - 008 | OB - 104 | OB - 105 | OB - 106 |
| | 1:15PM - 1:50PM | LUNCH BREAK | | | | |
| | 1.50PM - 4:00PM | OB - 007 | OB - 008 | OB - 104 | OB - 105 | OB - 106 |

NOTE:

1. All students are informed to attend the training compulsory.
2. Minimum attendance should be 85% failing which, students are not allowed for campus drives.
3. Placement dress code compulsory (White formal shirt & Black pant). Jeans are not allowed.
4. Students are strictly informed to be present in their allocated rooms only for all days.



Shuman G
PRINCIPAL
PRINCIPAL
K.S. INSTITUTE OF TECHNOLOGY
BENGALURU - 560 109.

CC TO:
HODs and Coordinators of:

| | | | |
|-----|-----|------|----|
| CSE | ECE | AIML | ME |
|-----|-----|------|----|



K.S INSTITUTE OF TECHNOLOGY

No.14, Raghuvanahalli, Kanakapura Main Road, Bengaluru - 560109

Phone: 080-28435722/24 website: www.ksit.ac.in

** DEPARTMENT OF TRAINING AND PLACEMENTS **

Date: 16/11/2022

CIRCULAR

As you are aware, Personality Development Training Program for 5th semester students (all branches) is scheduled from 17/11/2022 to 23/11/2022. Placement department has planned to conduct **pre-assessment test** on 16/11/2022 at Bizotic Platform between 5:00PM – 7:00PM. HODs and Coordinators of all the departments are requested to communicate to their pre-final year students accordingly.

The stepwise instructions for the registration process and steps to take the test are as follows;

Step 1: Registration Process:

(Please Note: If students have already registered, then please proceed to Step 2)

1. Go to the URL - ksit.bizoticedtech.com/signup
2. Email: Enter your **correct** email id.
3. Password: Set a password for your account.
4. Click on the button 'Sign Up'
5. In the next screen, enter your complete details such as: Full Name, Mobile Number, USN Number, Branch and Year of passing out (Please select your year of passing out as 2024).
6. Once you enter all the details, click on save. It will take you to the test screen.
7. Click on the bundle named "KSIT_2024 BATCH".
8. Click on the tab 'ENROLL FOR FREE'.
9. Click on the test series > Benchmarking > Benchmarking Test 1 > Take test.
10. Read the instructions and start the test.

Step 2: Login Process for Registered Students:

(Please Note: If students have not registered in the portal then please refer Step 1)

1. Go to the URL - ksit.bizoticedtech.com/signin
2. Email: Enter your **registered** email id.
3. Password: Enter your password
4. Click on the button 'Sign In'
5. If you have forgotten your password, then you can reset the password using the 'Forgot Password' tab.
6. Click on the test series > Benchmarking > Benchmarking Test 1 > Take test.

Test Details:

1. The test is for 60 minutes.
2. You will have 3 sections:
 - A. Quantitative Aptitude - 20 Questions - 25 Minutes
 - B. Logical Reasoning - 15 Questions - 20 Minutes
 - C. Verbal Ability - 15 Questions - 15 Minutes



Shruthi K.

PRINCIPAL

PRINCIPAL
K.S. INSTITUTE OF TECHNOLOGY
BENGALURU - 560 109.

CC to:

HODs and Coordinators of:

| | | | |
|-----|-----|------|------|
| CSE | ECE | AIML | MECH |
|-----|-----|------|------|



K.S INSTITUTE OF TECHNOLOGY

No.14, Raghuvanahalli, Kanakapura Main Road, Bengaluru – 560109

Phone: 080-28435722/24 website: www.ksit.ac.in

** DEPARTMENT OF TRAINING AND PLACEMENTS **

Date: 26/11/2022

CIRCULAR

This is to inform you that placement department has planned to conduct **post-assessment test** on **26/11/2022** for 5th semester B.E students at Bizotic Platform between **5:00PM – 9:00PM**. HODs and Coordinators of all the departments are requested to communicate to their pre-final year students accordingly.

The stepwise instructions for the registration process and steps to take the test are as follows;

The stepwise instructions for the registration process and steps to take the tests are as follows:

Step 1: Registration Process:

(Please Note: If students have already registered, then please proceed to Step 2)

1. Go to the URL - ksit.bizoticedtech.com/signup
2. Email: Enter your **correct** email id.
3. Password: Set a password for your account.
4. Click on the button 'Sign Up'
5. In the next screen, enter your complete details such as: Full Name, Mobile Number, USN Number, Branch and Year of passing out (Please select your year of passing out as 2024).
6. Once you enter all the details, click on save. It will take you to the test screen.
7. Click on the bundle named "KSIT_2024 BATCH".
8. Click on the tab 'ENROLL FOR FREE'.
9. Click on the test series > **Benchmarking**> **Benchmarking Test 2** > Take test.
10. Read the instructions and start the test.

Step 2: Login Process for Registered Students:

(Please Note: If students have not registered in the portal then please refer Step 1)

1. Go to the URL - ksit.bizoticedtech.com/signin
2. Email: Enter your **registered email id**.
3. Password: Enter your password
4. Click on the button 'Sign In'
5. If you have forgotten your password, then you can reset the password using the 'Forgot Password' tab.
6. Click on the test series > **Benchmarking**> **Benchmarking Test 2** > Take test.

Test Details:

1. The test is for 60 minutes.
2. You will have 3 sections:
 - A. Quantitative Aptitude - 20 Questions - 25 Minutes
 - B. Logical Reasoning - 15 Questions - 20 Minutes
 - C. Verbal Ability - 15 Questions - 15 Minutes
3. After you finish a section, you are required to click on the submit button. Once done, the system will take you to the next section. Your test will not be captured if you fail to click on the submit button.
4. Follow this process for all the 3 sections.
5. Click on the tab continue learning > and click **view result** > You will be able to see the detailed test report.

If you face any issues in accessing your account or while taking the test, then please drop in a mail from your registered mail id to info@bizotictalent.com with your complete details such as **Name, USN number, College, Email ID** and **Mobile number** with a brief about the issue faced.





PRINCIPAL
PRINCIPAL
K.S. INSTITUTE OF TECHNOLOGY
BENGALURU - 560 109.

CC to:
HODs and Coordinators of:

| | | | |
|-----|-----|------|------|
| CSE | ECE | AIML | MECH |
|-----|-----|------|------|



K.S INSTITUTE OF TECHNOLOGY

CONSOLIDATED ATTENDANCE FOR PDTP_5th Sem

COMPUTER SCIENCE AND ENGINEERING - OB 007

| III YEAR | | | V SEMESTER | | | | | | | | | 'A' SECTION | | | | | | |
|----------|------------|------------------------------|------------|---|---|------------|---|---|------------|---|---|-------------|----|----|------------|----|----|-------|
| S. No | USN | NAME OF THE STUDENT | Dates | | | | | | | | | | | | | | | TOTAL |
| | | | 17/11/2022 | | | 18/11/2022 | | | 21/11/2022 | | | 22/11/2022 | | | 23/11/2022 | | | |
| | | | 1 | 2 | 3 | 4 | 5 | 6 | 7 | 8 | 9 | 10 | 11 | 12 | 13 | 14 | 15 | |
| 1 | 1KS20CS001 | A AKASH | P | P | A | P | P | A | P | P | A | P | P | A | A | P | A | 09 |
| 2 | 1KS20CS002 | AAQIB BASHIR | P | P | P | P | P | A | P | P | A | P | P | A | P | A | A | 10 |
| 3 | 1KS20CS003 | ANAND V S | A | A | A | A | A | A | A | A | A | A | A | A | A | A | A | 00 |
| 4 | 1KS20CS004 | ANANYA PATIL | A | P | P | P | P | P | A | P | P | A | P | P | A | P | A | 10 |
| 5 | 1KS20CS005 | ANIRUDHA.K.K | P | P | A | P | P | A | P | P | P | A | A | A | P | A | A | 08 |
| 6 | 1KS20CS006 | ANKITA CHOUDHARY | P | P | P | P | P | P | A | P | A | P | A | A | A | A | A | 08 |
| 7 | 1KS20CS007 | ANUPRIYA C | P | P | P | P | P | A | P | A | A | P | P | A | P | A | 08 | |
| 8 | 1KS20CS008 | ANUSHREE G M | P | P | P | P | P | P | P | P | P | P | P | P | P | P | P | 15 |
| 9 | 1KS20CS009 | ANUSHREE H | P | P | P | P | P | A | P | P | P | A | P | A | A | A | A | 09 |
| 10 | 1KS20CS010 | APEKSHA M | P | P | P | P | P | P | P | P | A | P | P | A | A | A | A | 10 |
| 11 | 1KS20CS011 | ARCHIT GANAPATI AVADHANI | P | P | P | P | P | P | P | P | A | P | P | A | P | A | A | 11 |
| 12 | 1KS20CS012 | B JAIDEV | P | P | P | P | P | A | P | P | A | P | P | A | P | A | A | 10 |
| 13 | 1KS20CS013 | BASAVESH V L | P | P | P | P | P | P | P | P | A | P | P | A | P | A | A | 11 |
| 14 | 1KS20CS014 | BHUMIKA MAHADEVAPPA UMACHAGI | P | P | P | P | P | A | A | A | A | A | A | A | A | A | A | 05 |
| 15 | 1KS20CS015 | BHUVAN N GOWDA | P | P | P | P | P | P | P | P | P | P | P | A | P | A | A | 12 |
| 16 | 1KS20CS016 | BOMMINENI TEJASWINI | P | P | P | P | P | P | P | P | P | P | P | A | P | P | A | 12 |
| 17 | 1KS20CS017 | BRUNDA B | P | P | P | P | P | P | P | P | A | P | P | P | P | P | P | 14 |
| 18 | 1KS20CS018 | CHAITRA R | A | P | P | P | P | P | P | P | A | A | P | A | A | A | A | 08 |
| 19 | 1KS20CS019 | CETHAN S | P | P | P | P | P | P | P | P | A | A | A | A | P | A | A | 09 |
| 20 | 1KS20CS020 | DARSHAN M S | P | P | P | P | P | A | P | P | A | A | A | A | A | A | A | 07 |
| 21 | 1KS20CS021 | DHANUSH Y | P | P | A | A | P | A | A | P | P | A | A | A | P | P | A | 07 |
| 22 | 1KS20CS022 | DHANVIN C BHARGAV | P | P | P | P | P | P | P | P | P | P | P | A | P | P | A | 13 |
| 23 | 1KS20CS023 | DHANYA SHARANYA SHREE R | P | P | P | P | P | P | P | P | P | P | P | P | P | A | A | 13 |
| 24 | 1KS20CS024 | DIVAKAR M | A | P | A | A | A | A | P | A | P | P | A | A | A | A | A | 04 |
| 25 | 1KS20CS025 | DIVYA VEERAYYA CHIKKAMATH | A | P | P | P | P | P | P | P | A | P | P | P | P | A | A | 11 |
| 26 | 1KS20CS026 | EDUMUDI ABHINAYA | P | P | A | A | A | A | P | P | P | P | P | P | P | P | A | 10 |
| 27 | 1KS20CS027 | G SANJANA RAJU | P | P | P | P | A | P | A | A | A | P | A | A | P | P | A | 07 |
| 28 | 1KS20CS028 | GAGANA C L NAIK | P | P | P | P | P | A | A | P | P | P | P | A | P | P | P | 12 |
| 29 | 1KS20CS029 | GAGANA R | P | P | P | P | P | P | P | P | P | P | P | P | P | P | P | 15 |
| 30 | 1KS20CS030 | GANASHREE G M | P | P | P | P | P | P | P | P | P | A | A | A | P | P | P | 12 |
| 31 | 1KS20CS031 | GANASHREE K | P | P | P | P | P | P | P | P | A | P | P | P | P | P | P | 14 |
| 32 | 1KS20CS032 | GIRISH G | P | P | P | P | P | A | P | P | A | P | P | A | P | A | A | 10 |
| 33 | 1KS20CS033 | GOEL ANANYA DEVENDRA | P | P | P | A | P | P | P | P | A | A | P | P | A | A | A | 09 |
| 34 | 1KS20CS034 | GURU KASHYAP N S | A | A | A | A | A | A | A | A | P | A | P | A | A | P | A | 03 |
| 35 | 1KS20CS035 | GURU KIRAN S | P | P | P | P | P | P | P | P | P | P | A | A | P | P | A | 12 |
| 36 | 1KS20CS036 | H A SANKEERTHAN | P | P | A | P | P | P | P | P | P | A | A | A | A | A | A | 08 |
| 37 | 1KS20CS037 | H A TRISHALA | P | P | P | A | A | A | A | A | A | A | A | A | A | A | A | 03 |
| 38 | 1KS20CS038 | HARSHITHA B R | P | P | A | P | P | P | P | P | A | A | A | A | P | A | A | 08 |
| 39 | 1KS20CS039 | HONOKSHARATHNA B | P | A | A | P | P | P | P | P | A | A | P | P | A | A | A | 06 |
| 40 | 1KS20CS040 | HRITHIKA.S | P | P | A | A | A | A | A | P | A | A | A | A | A | A | A | 03 |
| 41 | 1KS20CS041 | JAHNAVI P | A | P | P | A | P | P | A | P | P | A | P | P | A | P | A | 09 |
| 42 | 1KS20CS042 | JEEVAN | P | P | P | P | P | P | P | P | P | P | P | P | A | A | A | 012 |

Computer - 'A'

| | | | | | | | | | | | | | | | | | | |
|--|------------|---------------------------|--------------------|--------------------|--------------------|--------------------|--------------------|--------------------|--------------------|--------------------|--------------------|--------------------|--------------------|--------------------|--------------------|--------------------|--------------------|--------------------|
| 43 | 1KS20CS043 | JNANESH A S | A | P | P | A | P | A | A | P | P | P | A | A | A | P | A | 07 |
| 44 | 1KS20CS044 | JONNA DILEEP | P | P | P | P | P | A | P | P | A | P | P | A | P | A | A | 10 |
| 45 | 1KS20CS045 | KAVITHA R | P | P | P | P | P | P | P | P | A | P | P | P | A | A | A | 11 |
| 46 | 1KS20CS046 | KAVYA R | P | P | P | P | P | P | P | P | A | P | P | P | A | A | A | 11 |
| 47 | 1KS20CS047 | KUSHAL K | A | P | P | A | P | A | A | P | P | A | A | A | P | A | A | 07 |
| 48 | 1KS20CS048 | LISHA NIDHI A M | A | P | P | P | P | P | P | P | A | A | A | A | P | A | A | 07 |
| 49 | 1KS20CS049 | M SANTOSHKUMAR M HAMPANNA | P | P | P | P | P | A | P | P | A | P | P | A | A | A | A | 09 |
| 50 | 1KS20CS050 | MAHIM SUBHASH AKHAWAT | P | P | P | A | A | A | A | P | P | A | P | P | P | P | P | 10 |
| 51 | 1KS20CS051 | MANDARA K S | P | P | P | P | P | P | P | P | P | P | P | P | P | P | A | 14 |
| 52 | 1KS20CS052 | MANISH PIKHAN | A | A | A | P | P | A | A | P | A | A | A | A | A | A | A | 03 |
| 53 | 1KS20CS053 | MANISHA G N | P | P | P | P | P | P | P | P | A | P | P | P | A | A | A | 11 |
| 54 | 1KS20CS054 | MANJUNATH R | P | P | P | P | P | A | P | P | P | A | P | A | A | A | A | 09 |
| 55 | 1KS20CS055 | MONICA C S | P | P | P | P | P | P | P | P | P | P | P | A | P | A | A | 12 |
| 56 | 1KS20CS056 | MONIESH.S | A | P | A | A | A | A | A | A | A | A | P | A | A | A | A | 02 |
| 57 | 1KS20CS057 | MONIKA N | P | P | P | P | P | P | P | P | A | P | P | P | A | A | A | 11 |
| 58 | 1KS21CS401 | PAVITHRA A S | A | A | A | A | A | A | A | A | A | A | A | A | A | A | A | 00 |
| 59 | 1KS21CS402 | S POORNACHANDRA | P | P | P | P | P | P | P | P | P | P | P | A | P | A | A | 12 |
| 60 | 1KS21CS403 | SANJEEV KULKARNI | A | A | A | P | P | P | P | P | A | P | P | A | P | A | A | 08 |
| 61 | 1KS21CS404 | SANTOSH N | A | A | A | A | A | A | A | A | A | A | A | A | P | A | A | 08 |
| 62 | 1KS21CS405 | SUHAS R | A | A | A | P | P | P | P | P | A | P | P | A | P | A | A | 08 |
| 63 | 1KS21CS406 | VAISHNAVI S SHARMA | A | A | A | P | P | P | P | P | A | P | P | A | A | A | A | 07 |
| 64 | 1KS21CS407 | VIDHYA J | P | P | P | P | P | P | P | P | A | P | P | A | P | A | A | 11 |
| No. of Students Absent | | | 18 | 08 | 18 | 15 | 12 | 26 | 19 | 11 | 37 | 24 | 20 | 31 | 45 | 57 | 02 | |
| No. of Students Present | | | 46 | 56 | 46 | 49 | 52 | 38 | 45 | 53 | 27 | 40 | 44 | 18 | 33 | 19 | 7 | 62 |
| Signature of trainer/placement coordinator | | | <i>[Signature]</i> | <i>[Signature]</i> | <i>[Signature]</i> | <i>[Signature]</i> | <i>[Signature]</i> | <i>[Signature]</i> | <i>[Signature]</i> | <i>[Signature]</i> | <i>[Signature]</i> | <i>[Signature]</i> | <i>[Signature]</i> | <i>[Signature]</i> | <i>[Signature]</i> | <i>[Signature]</i> | <i>[Signature]</i> | <i>[Signature]</i> |



6174



K.S INSTITUTE OF TECHNOLOGY

CONSOLIDATED ATTENDANCE FOR PDTP_5th Sem

COMPUTER SCIENCE AND ENGINEERING - OB 008

(Shamir)

| III YEAR | | | V SEMESTER | | | | | | 'B' SECTION | | | | | | | | | | |
|----------|------------|------------------------------|------------|----|----|------------|----|----|-------------|----|---|------------|----|----|------------|----|----|-------|-----|
| S. No | USN | NAME OF THE STUDENT | Dates | | | | | | | | | | | | | | | TOTAL | |
| | | | 17/11/2022 | | | 18/11/2022 | | | 21/11/2022 | | | 22/11/2022 | | | 23/11/2022 | | | | |
| | | | 1 | 2 | 3 | 4 | 5 | 6 | 7 | 8 | 9 | 10 | 11 | 12 | 13 | 14 | 15 | | |
| 1 | 1KS20CS058 | N KEERTHANA | P | P | P | P | P | P | P | P | P | P | P | P | P | P | P | P | 14 |
| 2 | 1KS20CS059 | NAJEEB MUTHAHEED ARIN UL HAQ | P | P | AB | P | AB | AB | A | A | A | A | A | A | A | A | A | A | 03 |
| 3 | 1KS20CS060 | NAMRATHA R | P | P | AB | A | P | AB | P | P | A | A | A | A | A | A | A | A | 05 |
| 4 | 1KS20CS061 | NARASIMHA N | P | P | P | P | P | P | P | P | P | A | A | P | P | A | A | A | 12 |
| 5 | 1KS20CS062 | NEHA REDDY S | P | P | P | P | P | P | A | A | A | P | P | A | P | P | A | A | 10 |
| 6 | 1KS20CS063 | NIDHI K V | P | P | P | P | P | P | A | P | A | P | A | A | P | P | A | A | 10 |
| 7 | 1KS20CS064 | NIRMITHA N | P | P | P | P | P | P | P | A | A | P | P | P | P | P | A | A | 12 |
| 8 | 1KS20CS065 | N NITESH KUMAR | P | P | AB | A | AB | AB | P | AP | A | P | A | A | A | A | A | A | 05 |
| 9 | 1KS20CS066 | NUTHANAPATI DEVITHA | AB | AB | AB | A | AB | AB | A | A | A | A | A | A | A | A | A | A | 00 |
| 10 | 1KS20CS067 | PARVASHREE H M | P | P | P | P | P | P | P | A | A | P | P | P | P | P | A | A | 12 |
| 11 | 1KS20CS068 | PARVATHY P S | AB | AB | AB | P | P | AB | P | A | A | P | P | A | P | P | A | A | 07 |
| 12 | 1KS20CS069 | PAVAN C | AB | AB | AB | A | AB | AB | A | A | A | A | A | A | A | A | A | A | 00 |
| 13 | 1KS20CS070 | PAVAN KUMAR S | AB | AB | AB | A | AB | AB | A | A | A | A | A | A | A | A | A | A | 00 |
| 14 | 1KS20CS071 | PAVAN M | P | P | P | P | P | P | P | P | A | P | P | A | P | A | A | A | 11 |
| 15 | 1KS20CS072 | PAVAN P | P | P | P | P | P | P | P | P | A | P | P | A | P | A | A | A | 11 |
| 16 | 1KS20CS073 | PAVITHRA R | P | P | P | P | P | P | P | A | A | P | P | P | P | P | A | A | 12 |
| 17 | 1KS20CS074 | POOJITHA Y | P | P | P | P | AB | AB | P | P | A | P | P | A | A | A | A | A | 08 |
| 18 | 1KS20CS075 | POONAM | P | P | P | P | P | P | P | A | A | P | P | P | P | P | A | A | 12 |
| 19 | 1KS20CS076 | PRADHYUMNA K | P | P | AB | P | P | AB | P | P | A | P | A | A | P | P | A | A | 09 |
| 20 | 1KS20CS077 | PRAJWAL NAIK U | AB | AB | AB | A | AB | AB | A | P | A | A | A | A | A | A | A | A | 01 |
| 21 | 1KS20CS078 | R.KUSHAL SAI | P | P | P | P | P | AB | P | P | A | P | A | P | P | A | A | A | 10 |
| 22 | 1KS20CS079 | RAGHAVI C S | P | P | P | P | P | P | A | A | A | A | A | A | P | P | A | A | 08 |
| 23 | 1KS20CS080 | RAKSHITH.C MAHALADKAR | P | P | AB | A | P | P | A | P | A | A | A | A | P | P | A | A | 07 |
| 24 | 1KS20CS081 | RAKSHITHA P | P | P | P | P | P | AB | P | A | A | P | P | A | P | P | A | A | 10 |
| 25 | 1KS20CS082 | ROSHAN KUMAR.B | AB | AB | AB | A | AB | AB | A | A | A | A | A | A | A | A | A | A | 00 |
| 26 | 1KS20CS083 | S.SAI SHANKARI | AB | AB | AB | P | P | AB | A | P | A | A | A | A | A | A | A | A | 02 |
| 27 | 1KS20CS084 | SAAHIL BHUJANG DHARMAJI | AB | AB | AB | P | P | AB | P | P | P | P | A | A | P | P | P | A | 09 |
| 28 | 1KS20CS085 | SABHAREESH BALAJI P | AB | P | AB | P | AB | AB | A | P | A | A | A | A | A | A | A | A | 02 |
| 29 | 1KS20CS086 | SAHANA R | P | P | P | P | P | P | P | P | P | P | P | P | P | P | A | A | 14 |
| 30 | 1KS20CS087 | SAMEER KULKARNI | AB | AB | AB | P | AB | AB | P | P | A | A | A | A | A | A | A | A | 03 |
| 31 | 1KS20CS088 | SANKET GANAPATI HEGDE | P | P | AB | P | P | AB | P | P | A | P | P | A | A | A | A | A | 08 |
| 32 | 1KS20CS089 | SHASHIKANTH N G | AB | P | AB | P | AB | AB | A | A | A | P | P | A | A | A | A | A | 04 |
| 33 | 1KS20CS090 | SHASHWATHA H M | AB | P | P | P | P | P | A | P | P | P | P | A | A | A | A | A | 09 |
| 34 | 1KS20CS091 | SHILPA M | P | P | P | P | P | P | P | P | P | P | P | P | P | P | P | P | 15 |
| 35 | 1KS20CS092 | SHRAVYA M R | P | P | P | P | P | P | P | P | A | P | P | A | P | P | A | A | 012 |
| 36 | 1KS20CS093 | SINDHURA H | P | P | P | P | P | P | P | A | A | P | P | P | P | P | P | P | 13 |
| 37 | 1KS20CS094 | SIRIPIREDDY THULASI | AB | AB | P | P | AB | AB | P | P | A | P | P | A | A | A | A | A | 06 |
| 38 | 1KS20CS095 | SKANDA SWAROOPA B V | AB | AB | AB | A | AB | AB | A | A | A | A | A | A | A | A | A | A | 00 |
| 39 | 1KS20CS096 | SPOORTHY.N | AB | P | P | P | P | P | A | P | P | P | P | A | A | A | A | A | 09 |
| 40 | 1KS20CS097 | SRISHTI SRIVASTAVA | AB | P | P | P | P | P | P | A | A | P | P | P | P | P | A | A | 11 |
| 41 | 1KS20CS098 | SUDEEP D M | AB | AB | AB | P | AB | AB | P | P | A | A | A | A | A | A | A | A | 03 |
| 42 | 1KS20CS099 | SUSHMA SRIKANTA KURANDWAD | P | P | P | P | P | AB | A | A | A | P | P | P | A | A | A | A | 07 |

| | | | | | | | | | | | | | | | | | | |
|--|------------|-----------------------|----|----|----|----|----|----|----|----|----|----|----|----|----|----|----|-----|
| 43 | 1KS20CS100 | TAHREEM IMAD PASHA | AB | AB | AB | A | AB | AB | A | A | A | A | A | A | A | A | A | 00 |
| 44 | 1KS20CS101 | TALIB MUKHTAR CHODA | P | P | P | P | P | AB | P | P | A | P | A | P | P | A | A | 10 |
| 45 | 1KS20CS102 | TANVI KAMATH | P | P | AB | P | AB | AB | P | A | A | P | P | A | P | A | A | 07 |
| 46 | 1KS20CS103 | THANUSHA K | P | P | P | P | P | P | P | A | A | P | P | P | A | A | A | 10 |
| 47 | 1KS20CS104 | TRUPTHI G B | P | P | P | P | P | P | A | A | A | P | P | A | A | A | A | 08 |
| 48 | 1KS20CS105 | TUSHAR S | P | P | P | P | P | P | A | P | A | P | P | A | P | A | A | 010 |
| 49 | 1KS20CS106 | V ARVIND | P | P | AB | A | AB | AB | A | A | A | P | P | A | A | A | A | 04 |
| 50 | 1KS20CS107 | VAISHNAVI M | P | P | P | P | P | AB | P | P | A | P | P | A | P | P | A | 11 |
| 51 | 1KS20CS108 | VANDANA N | AB | AB | P | P | P | P | P | P | P | P | P | P | P | P | A | 14 |
| 52 | 1KS20CS109 | VANDANA N | AB | AB | AB | P | P | AB | A | A | A | P | P | A | A | A | P | 05 |
| 53 | 1KS20CS110 | VIBHAV KAUSHIK V | AB | P | AB | A | P | AB | P | A | A | A | A | A | A | A | A | 03 |
| 54 | 1KS20CS111 | VIKAS KASHYAP R | AB | AB | AB | P | P | P | P | P | A | P | P | A | P | A | A | 09 |
| 55 | 1KS20CS112 | VISHAL N KORABU | P | P | AB | P | P | AB | P | A | A | P | P | A | A | A | A | 07 |
| 56 | 1KS20CS113 | VUMMANENI CHARAN | P | P | AB | P | AB | AB | A | A | A | A | A | A | A | A | A | 03 |
| 57 | 1KS20CS114 | Y JHANSI | AB | AB | AB | P | P | AB | A | A | A | A | A | A | A | A | A | 03 |
| 58 | 1KS20CS115 | MOHAMMAD TAHA | AB | AB | AB | A | AB | AB | A | P | A | A | A | A | A | A | P | 02 |
| 59 | 1KS20CS116 | ASHRIT MADHAV VADIRAJ | AB | P | P | P | P | AB | A | P | P | P | P | A | P | A | P | 10 |
| 60 | 1KS20CS117 | DEEPAK S | AB | P | P | A | P | AB | A | A | P | P | P | A | P | A | P | 07 |
| 61 | 1KS20CS118 | K R SAHANA | P | P | P | P | P | P | A | A | A | P | P | A | P | A | A | 08 |
| 62 | 1KS20CS119 | SNEHA A S | P | P | P | P | P | P | P | P | P | P | P | A | P | P | A | 13 |
| 63 | 1KS20CS120 | AJAY GIRISH | P | P | P | P | P | AB | P | P | P | P | P | A | P | P | A | 11 |
| 64 | 1KS20CS121 | SAKSHAM SINGH | AB | P | P | A | P | AB | A | A | P | A | P | A | P | A | A | 06 |
| 65 | 1KS20CS122 | RAVI VAMSHI D N | P | P | P | P | P | P | A | A | A | A | A | A | A | A | A | 06 |
| 66 | 1KS20CS123 | SANJANA G | P | P | P | P | P | AB | A | A | A | P | A | A | A | A | A | 06 |
| No. of Students Absent | | | 25 | 16 | 29 | 15 | 19 | 39 | 31 | 35 | 53 | 22 | P | 52 | 32 | 44 | 56 | 06 |
| No. of Students Present | | | 41 | 50 | 37 | 51 | 47 | 87 | 35 | 31 | 13 | 44 | 38 | 14 | 34 | 22 | 10 | 60 |
| Signature of trainer/placement coordinator | | | | | | | | | | | | | | | | | | |

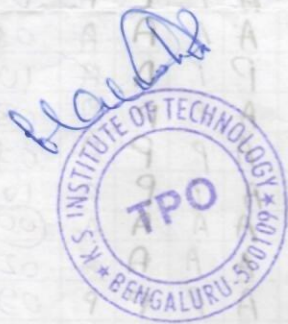



K.S INSTITUTE OF TECHNOLOGY

CONSOLIDATED ATTENDANCE FOR PDTP_5th Sem

ELECTRONICS & COMMUNICATION ENGINEERING - OB 104

| III YEAR | | | V SEMESTER | | | | | | 'A' SECTION | | | | | | | | | |
|----------|------------|-------------------------|------------|----|----|------------|---|---|-------------|---|---|------------|----|----|------------|----|----|-------|
| S.No | USN | NAME OF THE STUDENT | Dates | | | | | | | | | | | | | | | TOTAL |
| | | | 17/11/2022 | | | 18/11/2022 | | | 21/11/2022 | | | 22/11/2022 | | | 23/11/2022 | | | |
| | | | 1 | 2 | 3 | 4 | 5 | 6 | 7 | 8 | 9 | 10 | 11 | 12 | 13 | 14 | 15 | |
| 1 | 1KS19EC026 | ERAM FATHIMA | A | A | A | I | I | P | P | A | A | A | A | A | A | A | A | 04 |
| 2 | 1KS19EC034 | HIMA SWETHA S | 1 | 1 | I | I | I | A | P | P | A | P | P | P | P | A | A | 11 |
| 3 | 1KS20EC001 | ABHISHEK J | 1 | 1 | I | I | I | P | A | P | A | P | P | P | P | A | A | 12 |
| 4 | 1KS20EC002 | Aditi dubey | 1 | 1 | I | I | I | P | P | P | P | P | P | A | P | P | P | 14 |
| 5 | 1KS20EC003 | AFFEEFA SHARIEFF | 1 | 1 | I | I | I | P | P | P | P | P | P | A | P | P | P | 14 |
| 6 | 1KS20EC004 | Ajay B G | 1 | 1 | I | I | I | P | P | P | P | A | P | P | P | P | P | 14 |
| 7 | 1KS20EC006 | Akash M | AB | AB | AB | AB | I | P | A | P | A | A | P | P | A | P | A | 06 |
| 8 | 1KS20EC008 | B.S.HEMASHREE | 1 | 1 | I | I | I | P | P | P | P | P | P | P | P | P | P | 14 |
| 9 | 1KS20EC009 | BHARATH M | 1 | 1 | I | I | I | P | P | P | P | P | A | A | P | A | A | 11 |
| 10 | 1KS20EC010 | Bhavitha. B | 1 | 1 | I | I | I | P | P | P | A | P | P | A | P | P | P | 13 |
| 11 | 1KS20EC011 | Bhuvaneshwari k | 1 | 1 | I | I | I | P | P | P | A | P | P | P | P | P | P | 15 |
| 12 | 1KS20EC012 | Chaitanya k | 1 | 1 | I | I | I | P | P | P | P | P | P | A | P | A | P | 13 |
| 13 | 1KS20EC013 | CHAITHRA K | 1 | 1 | I | AB | A | A | P | P | P | P | P | P | A | A | A | 09 |
| 14 | 1KS20EC014 | C. Sai Srujitha | 1 | 1 | I | I | I | P | A | A | A | A | A | A | P | A | A | 07 |
| 15 | 1KS20EC015 | C.Umadevi | 1 | 1 | I | AB | I | P | P | P | P | A | A | A | A | P | A | 10 |
| 16 | 1KS20EC016 | Chaya. S | 1 | 1 | I | I | I | P | P | P | P | P | P | P | P | P | P | 15 |
| 17 | 1KS20EC017 | Chethan G | 1 | 1 | I | I | I | P | P | P | A | P | P | P | P | P | A | 13 |
| 18 | 1KS20EC018 | Chethankumar J | 1 | 1 | AB | I | I | P | P | P | A | P | P | A | P | P | A | 11 |
| 19 | 1KS20EC019 | CHEZHAN KUMAR T | 1 | 1 | I | I | I | P | P | P | A | P | A | P | P | P | A | 12 |
| 20 | 1KS20EC020 | DARSHAN K | 1 | 1 | I | AB | A | A | P | P | A | P | P | A | P | A | P | 09 |
| 21 | 1KS20EC021 | DARSHAN KUMAR S | 1 | 1 | I | I | I | P | P | P | P | P | P | P | A | P | P | 14 |
| 22 | 1KS20EC023 | Dhamini. J | 1 | 1 | I | I | I | P | P | P | P | P | P | P | P | P | P | 15 |
| 23 | 1KS20EC024 | Dhruva Kumar S | 1 | 1 | I | I | I | P | P | P | A | P | P | A | P | P | A | 12 |
| 24 | 1KS20EC025 | Divya .N | 1 | 1 | I | I | I | P | P | P | P | P | P | P | P | P | P | 15 |
| 25 | 1KS20EC026 | Eshwar Biradar | 1 | 1 | I | I | I | P | P | P | A | P | P | A | A | A | A | 10 |
| 26 | 1KS20EC027 | G BHAVANA PRIYADARSHINI | 1 | 1 | I | I | I | P | P | P | P | P | P | P | P | P | P | 15 |
| 27 | 1KS20EC028 | Gagan.H.C | AB | AB | AB | A | I | P | P | P | P | P | P | A | P | P | P | 11 |
| 28 | 1KS20EC029 | Gagana B S | 1 | 1 | I | I | I | P | P | P | A | P | A | A | A | A | A | 09 |
| 29 | 1KS20EC030 | Gandhamani C M | 1 | 1 | I | I | I | P | P | P | P | P | P | A | P | P | P | 14 |
| 30 | 1KS20EC031 | Gomitha R C | 1 | 1 | I | I | I | P | P | A | A | P | P | P | A | A | P | 11 |
| 31 | 1KS20EC032 | Harini k | 1 | 1 | I | AB | I | P | P | P | P | P | P | A | A | A | A | 11 |
| 32 | 1KS20EC033 | Harshitha gowda AR | 1 | 1 | I | I | I | P | P | P | P | P | P | P | P | P | P | 15 |
| 33 | 1KS20EC034 | Harshitha.B.L | 1 | 1 | I | I | I | P | P | P | P | P | P | P | P | P | P | 15 |
| 34 | 1KS20EC035 | Harshitha.J | 1 | 1 | I | I | I | P | P | P | A | P | P | P | P | P | A | 13 |
| 35 | 1KS20EC036 | HARSHITHA N | 1 | 1 | I | I | I | P | P | P | P | P | P | P | P | P | P | 15 |
| 36 | 1KS20EC037 | Inchara. P | 1 | 1 | I | I | I | P | P | P | A | P | A | A | A | A | A | 09 |
| 37 | 1KS20EC038 | Chalthanya krishna.J | 1 | 1 | I | I | I | P | P | P | P | P | P | A | P | A | A | 12 |
| 38 | 1KS20EC039 | Jamuna s g | 1 | 1 | I | I | I | P | P | A | A | P | A | P | A | A | P | 10 |
| 39 | 1KS20EC040 | Janhavi r | 1 | 1 | I | I | I | P | P | A | A | P | A | P | A | A | P | 10 |
| 40 | 1KS20EC041 | JAYANTH. H | 1 | 1 | I | I | I | P | P | P | A | P | P | P | A | P | P | 13 |
| 41 | 1KS20EC042 | K Jeevitha | 1 | 1 | I | I | I | P | P | P | P | P | A | A | A | A | A | 10 |
| 42 | 1KS20EC043 | K.M.Amshumanth | 1 | 1 | I | I | I | A | A | A | A | P | P | A | A | A | A | 07 |



K.S INSTITUTE OF TECHNOLOGY

CONSOLIDATED ATTENDANCE FOR PDTP_5th Sem

ELECTRONICS & COMMUNICATION ENGINEERING - OB 105

| III YEAR | | | V SEMESTER | | | | | | | 'B' SECTION | | | | | | | | |
|----------|------------|----------------------|------------|---|---|------------|---|---|---|-------------|---|----|------------|----|----|------------|----|-------|
| S. No | USN | NAME OF THE STUDENT | Dates | | | | | | | | | | | | | | | TOTAL |
| | | | 17/11/2022 | | | 18/11/2022 | | | | 21/11/2022 | | | 22/11/2022 | | | 23/11/2022 | | |
| | | | 1 | 2 | 3 | 4 | 5 | 6 | 7 | 8 | 9 | 10 | 11 | 12 | 13 | 14 | 15 | |
| 1 | 1KS20EC059 | N.shreya | P | P | P | P | P | P | P | P | P | P | P | A | P | P | A | 13 |
| 2 | 1KS20EC060 | NALLANI GOWTHAMI | A | A | A | P | A | A | P | P | P | P | P | P | P | P | A | 11 |
| 3 | 1KS20EC061 | NEHA CR | P | P | P | P | P | P | P | P | P | A | A | A | P | A | 10 | |
| 4 | 1KS20EC062 | NEHA NAGARAJ AIRANI | A | P | P | P | P | P | P | P | A | P | P | A | P | P | P | 12 |
| 5 | 1KS20EC063 | VASANTH Kumar | P | P | P | P | P | A | A | A | A | P | P | P | P | P | A | 10 |
| 6 | 1KS20EC064 | PAVAN.C | A | A | A | A | A | A | A | A | P | P | P | A | P | A | 04 | |
| 7 | 1KS20EC065 | Pavani TS | P | P | P | P | P | P | P | P | A | A | A | P | P | A | 11 | |
| 8 | 1KS20EC066 | Pradhyumna S Kashyap | A | A | A | A | A | A | A | A | P | P | P | P | A | 05 | | |
| 9 | 1KS20ec067 | Praveen D B | P | P | P | P | P | A | A | A | P | P | P | P | P | A | 10 | |
| 10 | 1KS20EC068 | Prema G | P | P | P | A | A | A | P | P | P | A | P | P | P | A | 11 | |
| 11 | 1KS20EC069 | PRIYANKA.H C | A | A | A | P | P | P | A | A | A | P | A | A | P | P | A | 06 |
| 12 | 1KS20EC070 | PRIYANKA K | P | P | P | P | P | P | A | A | A | A | A | A | P | P | A | 08 |
| 13 | 1KS20EC071 | Priyanka.M | P | P | P | P | P | P | P | A | P | P | P | P | P | A | 13 | |
| 14 | 1KS20EC072 | Pushpa DT | P | P | P | P | P | P | P | A | P | P | A | P | P | A | 12 | |
| 15 | 1KS20EC073 | RAHUL KRISHNAN V | P | P | P | P | P | P | A | A | A | P | P | A | P | A | 10 | |
| 16 | 1KS20EC074 | RAHUL R | P | P | P | A | A | A | A | P | P | A | A | A | A | A | 05 | |
| 17 | 1KS20EC075 | RAJATH K ACHAR | A | A | A | A | A | P | A | A | A | P | P | P | P | A | 06 | |
| 18 | 1KS20EC076 | Rakshith NM | P | P | P | P | P | P | A | A | A | P | P | P | A | A | 09 | |
| 19 | 1KS20EC077 | RAKSHITH.R | P | P | P | P | P | P | P | P | P | P | P | P | P | P | 15 | |
| 20 | 1KS20EC078 | Rakshitha A | P | P | P | P | P | P | P | P | P | A | A | P | P | A | 12 | |
| 21 | 1KS20EC079 | RAMESHWAR | A | A | A | P | P | P | P | P | A | P | A | A | A | A | 08 | |
| 22 | 1KS20EC080 | Ramya T | P | P | P | P | P | P | P | P | P | P | P | P | P | P | 15 | |
| 23 | 1KS20EC082 | Rohit A.k | P | P | A | A | P | P | A | A | A | P | P | P | A | P | A | 08 |
| 24 | 1KS20EC083 | S Arun Kumar | P | P | P | A | P | P | A | A | A | A | A | A | P | P | P | 08 |
| 25 | 1KS20EC084 | Sachin NM | P | P | P | P | P | P | P | P | P | P | P | P | P | A | 14 | |
| 26 | 1KS20EC085 | SADHANA.SRINIVAS | P | P | P | P | P | P | A | A | A | P | P | P | P | P | 12 | |
| 27 | 1KS20EC087 | Sandeep Y H | P | P | P | P | P | P | P | P | A | A | P | P | P | A | 13 | |
| 28 | 1KS20EC089 | Sanjana.G | A | A | A | A | A | A | A | A | A | A | A | A | A | A | 00 | |
| 29 | 1KS20EC091 | Sanjana T Gadikar | P | P | P | P | P | P | P | P | A | P | A | A | A | A | 09 | |
| 30 | 1KS20EC092 | Shakthi Anbazhagan M | P | P | P | P | P | P | P | P | P | P | P | A | P | A | 13 | |
| 31 | 1KS20EC093 | Sharath M | P | P | P | P | P | A | P | A | A | P | A | A | A | A | 04 | |
| 32 | 1KS20EC094 | SHASHANK S | P | P | P | A | P | P | P | P | P | P | P | P | P | A | 13 | |
| 33 | 1KS20EC095 | SHIVAREDDY B A | P | P | P | A | P | P | P | P | A | P | P | A | A | A | 10 | |
| 34 | 1KS20EC096 | Shreya H Padmanabha | P | P | P | P | P | P | P | A | A | A | P | P | P | P | 12 | |
| 35 | 1KS20EC097 | Shreyas M S | P | P | P | P | P | P | P | P | P | P | P | A | A | A | 12 | |
| 36 | 1KS20EC098 | Shreyas p s rao | P | P | P | A | P | A | P | P | A | P | P | P | A | A | 10 | |
| 37 | 1KS20EC099 | SHWETA DEEPAK K | P | P | P | P | P | P | P | A | A | A | P | P | P | P | 12 | |
| 38 | 1KS20EC101 | SONIKA.R | A | P | P | P | P | P | A | P | P | P | P | A | P | A | 11 | |
| 39 | 1KS20EC102 | SUMANA N | P | P | P | P | P | P | P | A | A | A | P | A | A | A | 08 | |
| 40 | 1KS20EC103 | SUMUKHA.S | P | P | P | P | P | P | P | A | P | P | P | A | P | A | 12 | |
| 41 | 1KS20EC104 | SURAKSHA.N | P | P | P | P | P | P | A | A | P | P | P | A | P | A | 12 | |
| 42 | 1KS20EC105 | Tarun Prasanna | P | P | P | P | P | P | P | A | P | P | P | P | P | A | 13 | |



K.S INSTITUTE OF TECHNOLOGY

CONSOLIDATED ATTENDANCE FOR PDTP_5th Sem

AIML + MECHANICAL ENGINEERING - OB 106

| III YEAR | | | V SEMESTER | | | | | | | | | | | | | TOTAL | | |
|----------|------------|---------------------------------|------------|---|---|------------|---|---|------------|---|---|------------|----|----|------------|-------|----|-----|
| S. No | USN | NAME OF THE STUDENT | Dates | | | | | | | | | | | | | | | |
| | | | 17/11/2022 | | | 18/11/2022 | | | 21/11/2022 | | | 22/11/2022 | | | 23/11/2022 | | | |
| | | | 1 | 2 | 3 | 4 | 5 | 6 | 7 | 8 | 9 | 10 | 11 | 12 | 13 | 14 | 15 | |
| 1 | 1KS20AI001 | ABHISHEK A | P | P | P | P | P | P | P | A | A | P | P | P | A | P | A | 11 |
| 2 | 1KS20AI002 | AMITH MAIYA.G | P | P | P | P | P | P | P | P | P | P | P | P | P | P | P | 15 |
| 3 | 1KS20AI003 | ANANYA .P. | A | A | A | A | A | A | A | A | A | A | P | A | P | P | | 03 |
| 4 | 1KS20AI004 | ANUSHA PHANIRAJ | P | P | P | P | A | P | P | A | A | A | A | P | A | P | | 09 |
| 5 | 1KS20AI005 | BHAVANASHREE.K.S | P | P | P | P | P | P | A | A | A | P | P | P | P | P | A | 11 |
| 6 | 1KS20AI006 | C.M.RITHIKA | P | P | P | P | P | P | P | P | P | P | P | P | P | A | A | 13 |
| 7 | 1KS20AI007 | CHANDAN.V.K | P | P | P | P | P | P | P | P | P | A | A | A | A | P | P | 11 |
| 8 | 1KS20AI008 | CHETAN VEERANA GOUDA MUDIGOUDRA | P | P | P | P | P | P | P | P | P | P | P | P | P | P | P | 15 |
| 9 | 1KS20AI009 | DHANUSH.P | A | A | A | P | P | P | P | P | P | P | P | P | P | P | A | 11 |
| 10 | 1KS20AI010 | DHARMAVARAPU LAKSHMI AARADHYA | P | P | P | P | P | A | P | P | A | A | A | P | P | A | | 10 |
| 11 | 1KS20AI011 | DISHA GUPTA | A | A | A | P | P | P | P | A | P | P | P | P | A | A | | 09 |
| 12 | 1KS20AI012 | GURUDEEP.R | A | A | A | A | A | A | A | A | A | P | P | P | P | P | P | 06 |
| 13 | 1KS20AI014 | KANDRA AKASH | P | P | P | P | A | P | P | P | P | P | P | P | A | P | A | 12 |
| 14 | 1KS20AI015 | KARTIK BHATT | A | A | P | P | A | P | P | A | P | P | P | P | P | P | P | 11 |
| 15 | 1KS20AI016 | LASYA BABU K.M. | P | P | P | P | P | P | P | P | P | P | P | P | P | A | A | 13 |
| 16 | 1KS20AI017 | LIKHITH.V | A | P | P | P | P | A | A | A | A | P | P | P | A | P | P | 09 |
| 17 | 1KS20AI018 | LITHEESH V.R. | P | P | P | P | P | P | P | P | P | A | A | A | A | P | A | 10 |
| 18 | 1KS20AI019 | LOKESH .N. | P | P | A | P | P | P | P | P | P | P | P | A | P | P | A | 012 |
| 19 | 1KS20AI020 | M. DIVYASHREE | P | P | P | P | A | P | P | A | P | P | P | A | P | A | | 11 |
| 20 | 1KS20AI021 | M.V. VARUN | P | P | P | P | P | P | P | A | P | P | P | P | P | P | P | 14 |
| 21 | 1KS20AI022 | MADHU S. SALIMATH | P | P | P | P | P | P | P | P | P | P | P | P | P | P | A | 14 |
| 22 | 1KS20AI023 | MEDI VINAY | P | P | P | P | P | P | P | P | A | A | A | A | P | A | | 10 |
| 23 | 1KS20AI025 | MONISH.M | A | P | P | P | P | A | P | P | A | P | P | P | A | P | P | 11 |
| 24 | 1KS20AI026 | NETHRANAND P.S. | P | P | P | P | P | P | P | P | P | P | P | A | P | P | A | 13 |
| 25 | 1KS20AI027 | NIRIKSHA.D | P | P | P | P | A | P | P | P | P | P | P | P | P | P | A | 13 |
| 26 | 1KS20AI028 | NISHITHA.S. | P | A | A | A | A | A | A | A | A | P | P | A | A | A | A | 03 |
| 27 | 1KS20AI030 | PAVAN KALYAN.N. | P | P | P | P | P | A | P | P | P | P | A | A | P | A | | 11 |
| 28 | 1KS20AI031 | POORNIMA.M.C | P | P | P | P | P | A | A | A | P | P | P | A | A | A | | 09 |
| 29 | 1KS20AI032 | PRIYANKA.A.H | P | P | P | P | P | A | A | A | P | P | P | P | P | P | A | 11 |
| 30 | 1KS20AI033 | RAKSHITA.PANDURANG KULKARNI | P | P | P | P | P | A | A | A | P | P | P | P | P | A | | 11 |
| 31 | 1KS20AI034 | RUPA RAJASRI PUTHINEEDI | P | P | P | A | A | A | P | P | A | P | A | A | A | A | A | 06 |
| 32 | 1KS20AI035 | SAGAR .P | P | P | A | P | P | P | P | P | P | P | P | P | P | P | A | 13 |
| 33 | 1KS20AI036 | SAHITHI BHASHYAM | P | P | P | P | A | P | P | A | A | A | A | P | P | P | | 10 |
| 34 | 1KS20AI037 | SHRUTHI. K | P | P | P | P | P | P | P | P | P | A | A | A | A | P | A | 11 |
| 35 | 1KS20AI038 | SINDHUJA CHINDIRALA | P | P | P | P | P | P | P | P | P | P | P | P | A | A | P | 13 |
| 36 | 1KS20AI039 | SNEHA G. PALANKER | P | A | A | A | A | A | P | A | A | P | P | A | A | A | A | 04 |
| 37 | 1KS20AI041 | TANMAYEE R | P | P | P | P | P | P | P | P | P | P | P | P | A | A | A | 12 |
| 38 | 1KS20AI042 | TEJASWINI L | P | P | P | P | P | P | P | P | P | A | A | A | P | P | P | 12 |
| 39 | 1KS20AI043 | V.PREETHI | P | P | P | P | P | P | P | P | P | A | A | A | A | P | A | 10 |
| 40 | 1KS20AI044 | VIPUL KANT TRIPATHI | P | P | P | P | P | P | P | P | A | P | P | P | P | P | P | 14 |
| 41 | 1KS20AI046 | YASHILA.R | P | P | P | P | P | P | P | P | P | P | P | P | A | A | A | 12 |

| | | | | | | | | | | | | | | | | | | |
|--|------------|-------------------|----|----|----|----|----|----|----|----|----|----|----|----|----|----|------|------|
| 42 | 1KS20AI047 | YOGITHA .S. | A | A | A | A | A | A | A | A | A | A | A | A | A | A | (00) | |
| 43 | 1KS20ME001 | DARSHAN S | A | A | A | A | A | A | A | P | P | P | P | A | A | A | 04 | |
| 44 | 1KS20ME002 | HARSHAVARDHAN.V | A | A | A | A | A | P | P | P | P | P | P | P | P | A | 08 | |
| 45 | 1KS20ME003 | HARYANK V KASHYAP | A | P | P | P | P | P | P | P | P | P | P | P | P | A | 13 | |
| 46 | 1KS20ME004 | KUSHAL KADAM | A | A | A | A | A | P | P | P | P | P | P | A | A | A | 06 | |
| 47 | 1KS20ME005 | PRANITHA.R | 1 | P | P | A | A | A | P | P | P | A | A | A | A | A | 05 | |
| 48 | 1KS20ME006 | SHALINI D S | A | A | A | A | A | A | A | A | A | A | A | A | A | A | (00) | |
| 49 | 1KS20ME007 | SHREYAS.S.K | 1 | P | P | P | P | P | P | P | P | P | P | A | A | P | 13 | |
| 50 | 1KS20ME008 | SUPRITH GOWDA J | A | A | A | A | A | P | P | P | P | P | P | A | A | A | 06 | |
| 51 | 1KS21ME400 | PRAVEEN K | A | A | A | A | A | A | A | A | A | A | A | A | A | A | (00) | |
| 52 | 1KS21ME401 | PRERAN GOWDA K | A | A | A | A | A | P | P | P | P | P | P | P | P | A | 08 | |
| 53 | 1KS21ME402 | VINEETH P | A | A | A | A | A | A | H | P | A | A | A | A | A | A | 01 | |
| 54 | 1KS19ME031 | SHREYAS H VASIST | A | A | A | A | A | A | H | A | A | P | P | P | A | A | 03 | |
| 55 | 1KS18ME421 | MADHU KIRAN H | A | A | A | P | A | A | P | P | P | P | P | P | A | A | 08 | |
| No. of Students Absent | | | 19 | 18 | 19 | 16 | 17 | 15 | 16 | 15 | 23 | 16 | 17 | 20 | 29 | 23 | 43 | (03) |
| No. of Students Present | | | 36 | 37 | 36 | 39 | 38 | 30 | 39 | 41 | 23 | 40 | 39 | 36 | 26 | 32 | 12 | (52) |
| Signature of trainer/placement coordinator | | | Ve | B | B | Ve | V | S | S | P | Ve | VM | S | S | Ve | VM | -B | |

4) 1KS19ME012 Chulurath.



| | | | | | | | | | | | | | | | | | | |
|--|---|---|----|----|----|----|----|----|----|----|----|----|----|----|----|----|------|------|
| 42 | A | A | A | A | A | A | A | A | A | A | A | A | A | A | A | A | (00) | |
| 43 | A | A | A | A | A | A | A | A | A | P | P | P | P | A | A | A | 04 | |
| 44 | A | A | A | A | A | P | P | P | P | P | P | P | P | P | P | A | 08 | |
| 45 | A | P | P | P | P | P | P | P | P | P | P | P | P | P | P | A | 13 | |
| 46 | A | A | A | A | A | P | P | P | P | P | P | P | P | A | A | A | 06 | |
| 47 | 1 | P | P | A | A | A | P | P | P | A | A | A | A | A | A | A | 05 | |
| 48 | A | A | A | A | A | A | A | A | A | A | A | A | A | A | A | A | (00) | |
| 49 | 1 | P | P | P | P | P | P | P | P | P | P | P | P | A | A | P | 13 | |
| 50 | A | A | A | A | A | P | P | P | P | P | P | P | P | A | A | A | 06 | |
| 51 | A | A | A | A | A | A | A | A | A | A | A | A | A | A | A | A | (00) | |
| 52 | A | A | A | A | A | P | P | P | P | P | P | P | P | P | P | A | 08 | |
| 53 | A | A | A | A | A | A | H | P | A | A | A | A | A | A | A | A | 01 | |
| 54 | A | A | A | A | A | A | H | A | A | A | P | P | P | P | A | A | 03 | |
| 55 | A | A | A | P | A | A | P | P | P | P | P | P | P | P | A | A | 08 | |
| No. of Students Absent | | | 19 | 18 | 19 | 16 | 17 | 15 | 16 | 15 | 23 | 16 | 17 | 20 | 29 | 23 | 43 | (03) |
| No. of Students Present | | | 36 | 37 | 36 | 39 | 38 | 30 | 39 | 41 | 23 | 40 | 39 | 36 | 26 | 32 | 12 | (52) |
| Signature of trainer/placement coordinator | | | Ve | B | B | Ve | V | S | S | P | Ve | VM | S | S | Ve | VM | -B | |

SESHAASAI (M) CTS - 2010 22.07.2022 5144873

AXIS BANK LTD
JPNAGAR, 6TH PHASE BANAGLORE (K, BENGALURU, 560078
IFS CODE - UTIB0001513

A/c. PAYEE ONLY

VALID FOR THREE MONTHS FROM THE DATE OF ISSUE
DATE 25/11/2022
दिनांक D D M M Y Y Y Y

Pay Universal Education

OR BEARER / या धारक को

रुपये Rupees One lakh fifty nine thousand
nine hundred thirty eight only अदा करें

₹ 1,59,938/-

A/C NO. 912010014093916

For K S INSTITUTE OF TECHNOLOGY

PLTRS 000160

Authorized Signatory(ies)
Please sign above

Payable at par at all branches of Axis Bank Ltd in India.

⑈ 224464⑈ 560211034⑈ 000160⑈ 31

Revised cheque
to. Ravi Rai



Kammavari Sangham (R) 1952
K.S. GROUP OF INSTITUTIONS

ಕೆ.ಎಸ್. ತಾಂತ್ರಿಕ ಮಹಾವಿದ್ಯಾಲಯ

K.S. INSTITUTE OF TECHNOLOGY

Accredited By NAAC

14, Raghuvanahalli, Kanakapura Road, Bengaluru - 560 109.

Tel : 080 28435722 / 24, Fax : 080 28435723

E-mail : principal.ksit@gmail.com / principal@ksit.edu.in | website : www.ksit.edu.in

Ref: KSIT/PO/2022-2023/TPO 006

Date: 20/10/2022

To,
Universal Education
No. 93, 17th Cross, 33rd Main, JP Nagar 6th Phase, Bangalore - 560078

Dear Sir,

Sub: Purchase Order for Personality Development Training Program for Final Year B.E Students.

With reference to the above, we are pleased to place the order for **Personality Development Training Program** for 7th Semester Students at K.S. Institute of Technology, #14, Raghuvanahalli, Kanakapura Road, Bangalore – 109 as per the following specifications, terms & conditions.

Programme Commercials:

| SLNo. | Description | Quantity | Rate | Amount |
|-------|---|----------|---|----------------------|
| 1 | Personality Development Training Program for Final Year B.E Students. | 251 | Rs. 20/Hour/Student (251 × 30Hrs × 20Rs) | 1,50,600/- |
| | Total | | | 1,50,600/- |
| | Taxable Value | | | 27,108/- |
| | ADD: CGST 9% | | | 13,554/- |
| | ADD: SGST 9% | | | 13,554/- |
| | Grand TOTAL | | | 1,77,708.00/- |

Amount in Words: Rupees One Lakh Seventy Seven Thousand and Seven Hundred Eight Only

Terms & Conditions:

- Training for 7th Semester students would be from 2nd – 8th November 2022.
- Pre assessment and post assessment test would be conducted at company's portal only and report to be submitted on or before 14th November 2022.
- Full Payment to be made post satisfactory completion of the training.

Thanking you,

Hon. Secretary

KAMMAVARI SANGHAM



K S GROUP OF INSTITUTIONS
DEPARTMENT OF TRAINING AND PLACEMENTS
COMPARATIVE STATEMENT OF TRAINING VENDORS

| Name of Training Agency | Trainer Profile and Rating | | | | | Training Cost / Student / Hour |
|--|----------------------------|---|------------------------------|-------------------------|-------------------------|--|
| | 1 Name | 2 Qualification | 3 Professional Experience | 4 Specialization | 5 Rating and Remarks | |
| AUDAZ | Asgar Pasha | B.Sc MBA HR | 18 years | Personality Development | 3+5 = 8 | AVG Score - 33/4 = 8.25 ✓ (Offline) = 20.5/Student/Hr + GST |
| | Belliapa | B.E. M.Tech | 30 year | Soft Skills | 4+5 = 9 | |
| | Parvathi | B.A.M.A. MBA HR | 18 years | Personality Development | 3+5 = 8 | |
| | Kavitha M | B.Sc (Physics, Maths & Electronics) M.sc (Maths) M.A. English | 20 years | Aptitude & Soft Skills | 3+5 = 8 | |
| Assessment Portal-Own portal available | | | | | 33 | |

III Sem (KSIT + KSSEP)
17 + 0.25

| | | | | | | |
|----------------------------------|------------------------|-------------------|----------|------------------------|---------|--|
| BIZOTIC | SRINATH SETHURAMAN | M.Sc, MBA (UK) | 20 Years | Soft Skills and Verbal | 3+5 = 8 | AVG Score - 33/4 = 8.25 ✓ (Offline) = 20/Student/Hr + GST |
| | VINEET MANN | B.Sc, M.Sc | 15 Years | Aptitude | 3+5 = 8 | |
| | SHASHIKALA MADHUSUDHAN | LLB, M.Sc | 22 Years | Soft Skills and Verbal | 3+5 = 8 | |
| | K KRISHNA BAI | B.E, M.Tech (BSP) | 10 Years | Technical & Aptitude | 4+5 = 9 | |
| Assessment- Own Portal Available | | | | | 33 | |

V Sem (KSIT + KSSEP)
20 + 0.25
K. Jans 18/10/20

| | | | | | | |
|----------------------------------|--------------|------------------------------------|----------|-------------------------------|-----------|--|
| Quan Tech Origin | Deepak P.N. | B.E, M.E | 08 Years | English and Soft skills | 3+4 = 7 | AVG Score - 25/4 = 6.25 ✓ (Offline) = 20/Student/Hr + GST |
| | SAMUEL JOHN | Diploma (counselling skills), B. A | 12 Years | Communication and Soft Skills | 1+5 = 6 | |
| | Vignesh M.K. | B. E | 6 Years | Aptitude | 2+3 = 5 | |
| | Ananth P | B. E | 15 Years | Technical & Aptitude | 2 + 5 = 7 | |
| Assessment -Own Portal Available | | | | | 25 | |

+

| | | | | | | |
|---------|--------------|-----------------|----------|----------------------------|---------|---|
| Transit | Beena N | B.Sc, MS, PGDBA | 22 Years | Behaviour skills, Aptitude | 4+5 = 9 | AVG Score - 28/4 = 7 (Offline) = 23/Student/Hr + GST |
| | Sowmya Kerur | B E | 08 Years | Aptitude | 2+4 = 6 | |
| | AMIT MONDLE | | 20 Years | Personality Development | 2+3 = 5 | |
| | Arun Kumar | M.Sc, MBA | 17 Years | Technical & Aptitude | 3+5 = 8 | |
| | | | | | 28 | |

Assessment - Still Under Development

MBA (I & II year)

19+ GST

| | | | | | | |
|---------------|-------------|--------------------------------------|----------|--|----------|--|
| Skill Factory | Raghavan | B.Com & MBA (HR) | 14 Years | Soft Skills and Verbal Skills | 3+5 = 8 | AVG Score - 33/4 = 8.25 (Offline) = 21/Student/Hr + GST |
| | Nisha | B.Com & MBA (Fin) | 10 Years | Logical, Analytical and Verbal | 3+5 = 8 | |
| | Dr. Jacob S | Ph.D | 14 Years | Placement oriented skills, verbal skills | 5+5 = 10 | |
| | Narasimha | B.E (Information Science) & MBA (HR) | 8 Years | Logical, Analytical and Verbal | 3+4 = 7 | |
| | | | | | 33 | |

Assessment - Still Under Development

(KSIT + KSSEM)

VII Semester

20+ GST 18%

| | | | | | | |
|---------------------|----------------|-------------|----------|---------------------------------|---------|---|
| Universal Education | Avishek Ghosh | B.Sc, MBA | 12 Years | Aptitude and Reasoning | 3+5 = 8 | AVG Score - 34/4 = 8.5 (Offline) = 22/Student/Hr + GST |
| | V Nandini Nair | B.Sc, MBA | 12 Years | Verbal and communication skills | 3+5 = 8 | |
| | Ahishu Ghosh | B.E, MBA | 12 Years | Aptitude and Reasoning | 4+5 = 9 | |
| | Tapas Guha | B.E, M.Tech | 12 Years | Technical Trainer | 4+5 = 9 | |
| | | | | | 34 | |

Assessment - Still Under Development

| | | | | | | |
|-----------|-------------|---------------------|----------|---------------------------|---------|--|
| JV Global | Darshan B V | B.E, Mtech | 6 Years | Quantitative & Analytical | 4+3 = 7 | AVG Score - 31/4 = 7.75 (Offline) = 25/Student/Hr + GST |
| | Bhargav A P | BA, MA | 10 Years | Soft skills | 4+4 = 8 | |
| | Beena N | B.Sc, PG, MS, PGDBA | 18 Years | Pre Placement Topics | 4+5 = 9 | |
| | Beena S | BE, Mtech | 6 Years | Quantitative & Analytical | 4+3 = 7 | |
| | | | | | 31 | |

| | | | | | | |
|----------------|----------------|------------|----------|---------------------------------|---------|--|
| Pentagon Space | Yashwanth K N | BBM, MBA | 6 Years | Verbal and communication skills | 3+3 = 6 | AVG Score - 30/4 = 7.50 (Offline) = 32/Student/Hr + GST |
| | Hanu R | BE, M.Tech | 08 Years | Technical Trainer | 4+4 = 8 | |
| | DASHRATH MISAL | B.Com, MA | 15 Years | Soft skills and english | 3+5 = 8 | |
| | ARCHANA M S | B.Com, MBA | 13 Years | Soft skills | 3+5 = 8 | |
| | | | | | 30 | |

Call the above for negotiations.

6/10/22

Handwritten signature and date: 06/10/22



K.S INSTITUTE OF TECHNOLOGY

#14, Raghuvanahalli, Kanakapura Main Road, Bengaluru - 560109
Phone: 080-28435722/24 website: www.ksit.ac.in

** DEPARTMENT OF TRAINING AND PLACEMENTS **

28.10.2022

PERSONALITY DEVELOPMENT TRAINING PROGRAM FOR FINAL YEAR STUDENTS - 2023 BATCH

Placement department has planned to conduct **Personality Development Training Program** for 7th Semester students (All branches) from 2nd to 8th November 2022. All HOD's are hereby informed to communicate their final year students regarding the same.

The training will be conducted in **old building class rooms**. Batch wise details are shared below. All **placement coordinators** are **requested** to submit the consolidated attendance of all 5 days to placement department on or before 9th November 2022 without fail.

Department wise scheduled is given below for your reference.

| Date | Time | BATCH 1 | BATCH 2 | BATCH 3 | BATCH 4 | BATCH 5 |
|--|-------------------|-------------|----------|----------|-----------|----------|
| | | CSE (A) | CSE (B) | ECE (A) | ECE + ETE | ME |
| 2 nd , 3 rd , 4 th , 7 th & 8 th November 2022 | 8:50 AM - 11:00AM | OB - 104 | OB - 105 | OB - 106 | OB - 007 | OB - 008 |
| | 11:00AM - 11:15AM | BREAK | | | | |
| | 11:15 AM - 1:15PM | OB - 104 | OB - 105 | OB - 106 | OB - 007 | OB - 008 |
| | 1:15PM - 1:50PM | LUNCH BREAK | | | | |
| | 1.50PM - 4:00PM | OB - 104 | OB - 105 | OB - 106 | OB - 007 | OB - 008 |

NOTE:

1. Students who are absent for the training sessions will not be permitted to attend any campus drives.
2. All students are informed to attend the training compulsory.
3. Students are strictly informed to be present in their allocated rooms only for all days.
4. Placement dress code compulsory.



Shomas. G.
PRINCIPAL
PRINCIPAL
K.S. INSTITUTE OF TECHNOLOGY
BENGALURU - 560 109.

CC TO:
HODs and Coordinators of:

| | | | | | | | |
|-----|---|-----|-----------|-----|--|----|-------------|
| CSE | ✓ | ECE | <i>EA</i> | ETE | | ME | <i>ADAS</i> |
|-----|---|-----|-----------|-----|--|----|-------------|

UNIVERSAL EDUCATION

Training for

KSIT, Bengaluru (7th Semester)

Note-

1. This schedule is for 30 hours, commencing from November 2nd to 8th (excluding 5th and 6th)
2. There will be 6 hours of Training per day per batch.
3. Keeping 300 students we have divided batches into 5.
4. As per the requirement we will keep the link active for pre-assessment from 29th October (9am) to 31st October (9pm).
5. We will keep the link active for post assessment from 8 November (8pm) to 9 November (8 pm)

Please find below the syllabus lesson plan.

Q.A- Quantitative Aptitude

V.A- Verbal Aptitude

R.A- Reasoning Aptitude

R.P- Resume Preparation

H.R- Human Resource

G.D- Group Discussion

P.D- Personality Development

M.I- Mock Interview

Puzz- Puzzles

| DATE | TIME | BATCH 1 | BATCH 2 | BATCH3 | BATCH4 | BATCH 5 | |
|---------------------|-------------------|-------------|---------|---------------------|-------------------------|---------|--|
| | | | | | | | |
| 2 nd Nov | 9.00AM -11.00AM | Q.A1 | Q.A2 | V.A1 (Projector) | P.D+ R.P (Projector) | G.D1 | |
| | 11.00AM - 11.15AM | TEA BREAK | | | | | |
| | 11.15AM - 1.15PM | V.A1 | P.D+R.P | Q.A1 | Q.A2 | G.D1 | |
| | 1.15PM – 1.55PM | LUNCH BREAK | | | | | |
| | 2.00PM – 4.00PM | G.D1 | V.A1 | P.D+R.P | Q.A1 | Q.A2 | |

| DATE | TIME | BATCH 1 | BATCH 2 | BATCH3 | BATCH4 | BATCH 5 | |
|---------------------|-------------------|-------------|---------|--------|--------|---------|--|
| | | | | | | | |
| 3 rd Nov | 9.00AM -11.00AM | G.D1 | Q.A1 | Q.A2 | V.A1 | P.D+R.P | |
| | 11.00AM - 11.15AM | TEA BREAK | | | | | |
| | 11.15AM - 1.15PM | Q.A2 | G.D1 | R.A1 | V.A2 | Q.A1 | |
| | 1.15PM – 1.55PM | LUNCH BREAK | | | | | |
| | 2.00PM – 4.00PM | P.D+R.P | G.D1 | Q.A4 | Q.A3 | V.A1 | |

| DATE | TIME | BATCH 1 | BATCH 2 | BATCH3 | BATCH4 | BATCH 5 | |
|---------------------|-------------------|-------------|---------|--------|--------|---------|--|
| | | | | | | | |
| 4 th Nov | 9.00AM -11.00AM | Q.A4 | Q.A3 | G.D1 | R.A1 | V.A2 | |
| | 11.00AM - 11.15AM | TEA BREAK | | | | | |
| | 11.15AM - 1.15PM | V.A2 | R.A1 | G.D1 | Q.A4 | Q.A3 | |
| | 1.15PM – 1.55PM | LUNCH BREAK | | | | | |
| | 2.00PM – 4.00PM | Q.A3 | Q.A4 | V.A2 | G.D1 | R.A1 | |

| DATE | TIME | BATCH 1 | BATCH 2 | BATCH3 | BATCH4 | BATCH 5 | |
|---------------------|-------------------|----------------|---------------|---------------|----------------|----------------|--|
| | | | | | | | |
| 7 th Nov | 9.00AM -11.00AM | R.A1 | V.A2 | Q.A3 | G.D1 | Q.A4 | |
| | 11.00AM - 11.15AM | TEA BREAK | | | | | |
| | 11.15AM - 1.15PM | Q.A6 | Q.A6 | Q.A6 | Q.A5 + Puzz | Q.A5 + Puzz | |
| | 1.15PM – 1.55PM | LUNCH BREAK | | | | | |
| | 2.00PM – 4.00PM | Q.A5 + Puzz | Q.A5+ Puzz | Q.A5+ Puzz | Q.A6 | Q.A6 | |

| DATE | TIME | BATCH 1 | BATCH 2 | BATCH3 | BATCH4 | BATCH 5 | |
|---------------------|-------------------|-------------|-----------|-----------|-----------|-----------|--|
| | | | | | | | |
| 8 th Nov | 9.00AM -11.00AM | M.I | M.I | M.I | M.I | M.I | |
| | 11.00AM - 11.15AM | TEA BREAK | | | | | |
| | 11.15AM - 1.15PM | M.I | M.I | M.I | M.I | M.I | |
| | 1.15PM – 1.55PM | LUNCH BREAK | | | | | |
| | 2.00PM – 4.00PM | M.I + H.R | M.I + H.R | M.I + H.R | M.I + H.R | M.I + H.R | |

| | | | | | | | | | | | | | | | | | | | |
|--|------------|--------------------------|--------------------|--------------------|--------------------|--------------------|--------------------|--------------------|--------------------|--------------------|--------------------|--------------------|--------------------|--------------------|--------------------|--------------------|--------------------|--------------------|--------------------|
| 44 | 1KS19CS048 | LIKITH G | 1 | 2 | A | 3 | 4 | A | 5 | 6 | 7 | 8 | 9 | A | 10 | 11 | A | 11 | 9 |
| 45 | 1KS19CS049 | LISHA C | A | A | A | A | A | A | 1 | 2 | A | A | A | A | A | A | A | 02 | 1 |
| 46 | 1KS19CS050 | MAHAK SHREE | A | A | A | A | A | A | A | A | A | A | A | A | A | A | A | (00) | 0 |
| 47 | 1KS19CS051 | MALLIPALLI SPURTHI REDDY | 1 | 2 | A | 3 | 4 | A | 5 | 6 | 7 | 8 | 9 | 10 | A | A | A | 10 | 6 |
| 48 | 1KS19CS052 | MANASA G L | 1 | 2 | A | A | A | A | 3 | 4 | 5 | 6 | 7 | 8 | 9 | 10 | A | 10 | 6 |
| 49 | 1KS19CS053 | MOHAMMED NOOR AMAN | A | A | A | 1 | 2 | 3 | 4 | 5 | 6 | 7 | 8 | 9 | A | 10 | 11 | 11 | 8 |
| 50 | 1KS19CS054 | MUKESH KUMAR | A | A | A | A | A | A | A | A | A | A | A | A | A | A | A | (00) | 0 |
| 51 | 1KS19CS055 | MYTHREYI U | A | A | A | 1 | 2 | 3 | 4 | 5 | 6 | 7 | 8 | 9 | A | A | A | 09 | 6 |
| 52 | 1KS19CS056 | N ASHOK | A | A | A | A | A | A | A | A | 1 | 2 | 3 | 4 | 5 | A | A | 05 | 3 |
| 53 | 1KS19CS057 | N BHAVYA | 1 | 2 | A | 3 | 4 | A | 5 | 6 | 7 | 8 | 9 | 10 | A | A | A | 10 | 6 |
| 54 | 1KS19CS058 | N P SHASHANKA RAO | 1 | 2 | A | 3 | 4 | A | 5 | 6 | A | 7 | 8 | 9 | A | A | A | 09 | 5 |
| 55 | 1KS18CS011 | BHARATH R | A | A | A | 1 | A | A | A | A | A | 2 | 3 | A | A | A | A | 03 | 2 |
| 56 | 1KS19CS116 | VRATHIKA BILLAVA | 1 | 2 | A | A | A | A | A | A | A | 3 | 4 | 5 | 6 | 7 | A | 07 | 4 |
| 57 | 1KS20CS400 | AKIF DELVI | A | A | A | A | A | A | A | A | A | A | A | A | A | A | A | (00) | 0 |
| 58 | 1KS20CS404 | PRANAV CHANDRAN P | A | A | A | A | A | A | A | A | A | A | A | A | A | A | A | (00) | 0 |
| 59 | 1KS20CS402 | KEERTHI KUMAR V | 1 | A | A | A | A | A | A | A | A | 2 | 3 | 4 | A | 5 | A | 05 | 4 |
| No. of Students Absent | | | 34 | 44 | 54 | 38 | 38 | 50 | 31 | 26 | 32 | 21 | 20 | 24 | 48 | 43 | 53 | (10) | |
| No. of Students Present | | | 25 | 15 | 05 | 21 | 21 | 09 | 28 | 33 | 27 | 38 | 39 | 35 | 11 | 16 | 06 | 49 | |
| Signature of trainer/Placement Coordinator | | | <i>[Signature]</i> | <i>[Signature]</i> | <i>[Signature]</i> | <i>[Signature]</i> | <i>[Signature]</i> | <i>[Signature]</i> | <i>[Signature]</i> | <i>[Signature]</i> | <i>[Signature]</i> | <i>[Signature]</i> | <i>[Signature]</i> | <i>[Signature]</i> | <i>[Signature]</i> | <i>[Signature]</i> | <i>[Signature]</i> | <i>[Signature]</i> | <i>[Signature]</i> |





K.S INSTITUTE OF TECHNOLOGY, BENGALURU

CONSOLIDATED ATTENDANCE FOR PDTP_2023 BATCH

CSE (B) - OB 105

| IV YEAR | | | VII SEMESTER | | | | | | 'B' SECTION | | | | | | | | | |
|---------|------------|----------------------|--------------|---|---|------------|---|---|-------------|---|---|------------|----|----|------------|----|----|-------|
| S. No | USN | NAME OF THE STUDENT | Dates | | | | | | | | | | | | | | | TOTAL |
| | | | 02/11/2022 | | | 03/11/2022 | | | 04/11/2022 | | | 07/11/2022 | | | 08/11/2022 | | | |
| | | | 1 | 2 | 3 | 4 | 5 | 6 | 7 | 8 | 9 | 10 | 11 | 12 | 13 | 14 | 15 | |
| 1 | 1KS19CS059 | NAVEEN K M | A | A | A | A | A | A | A | 1 | A | 2 | A | A | A | A | 02 | |
| 2 | 1KS19CS060 | NEELAMMA SALI | 1 | A | A | A | A | A | 2 | 3 | A | A | A | A | A | A | 03 | |
| 3 | 1KS19CS061 | NETHRA R | A | A | A | A | A | A | 1 | A | A | A | A | A | A | A | 01 | |
| 4 | 1KS19CS062 | NIKHIL CHOWDARY V R | 1 | A | A | 2 | A | A | 3 | A | 4 | 5 | A | A | 6 | A | 06 | |
| 5 | 1KS19CS063 | NITHYA S N | 1 | A | 2 | A | A | A | 3 | 4 | A | 5 | A | A | 6 | A | 06 | |
| 6 | 1KS19CS064 | PAVAN B INDRESH | A | A | A | A | A | A | A | A | A | A | A | 1 | A | A | 01 | |
| 7 | 1KS19CS065 | PAVAN L | 1 | A | A | 2 | A | A | 3 | A | 4 | 5 | A | A | 6 | A | 06 | |
| 8 | 1KS19CS066 | PAVITHRA S P | A | A | A | A | A | A | A | A | A | A | A | 1 | A | A | 00 | |
| 9 | 1KS19CS067 | POOJA J | A | A | A | A | A | A | 1 | 2 | 3 | A | A | A | A | A | 03 | |
| 10 | 1KS19CS068 | POTHURU SAI PRIYANKA | A | A | A | 1 | 2 | A | 3 | 4 | 5 | 6 | 7 | A | A | A | 07 | |
| 11 | 1KS19CS069 | PRAJWAL G | 1 | 2 | A | 3 | 4 | A | A | 5 | A | A | A | A | A | A | 05 | |
| 12 | 1KS19CS070 | PRAJWAL KULKARNI | A | A | A | 1 | 2 | A | 3 | 4 | A | 5 | A | A | A | A | 05 | |
| 13 | 1KS19CS071 | PREETHI K P | A | A | A | 1 | 2 | A | 3 | 4 | A | 5 | A | A | A | A | 05 | |
| 14 | 1KS19CS072 | PRIYA E | 1 | A | 2 | A | A | A | 3 | 4 | A | 5 | A | A | A | A | 05 | |
| 15 | 1KS19CS073 | PRIYANKA R | 1 | A | A | 2 | A | A | 3 | 4 | 5 | 6 | A | A | A | A | 06 | |
| 16 | 1KS19CS074 | PUVAN KUMAR V | A | A | A | A | A | A | A | A | 1 | A | A | A | A | A | 01 | |
| 17 | 1KS19CS075 | R V YASHVANTH | A | A | A | A | A | A | A | A | 1 | A | A | A | A | A | 01 | |
| 18 | 1KS19CS076 | RAJ KUMAR | A | A | A | A | A | A | A | A | A | A | A | A | A | A | 00 | |
| 19 | 1KS19CS077 | RAKESH M J | 1 | A | A | A | A | A | A | A | A | 2 | A | A | A | A | 02 | |
| 20 | 1KS19CS078 | RAKSHA T M | 1 | 2 | A | 3 | A | A | 4 | 5 | 6 | 7 | 8 | A | A | A | 08 | |
| 21 | 1KS19CS079 | RANJITHA D V | A | A | A | 1 | 2 | A | 3 | 4 | 5 | 6 | 7 | A | A | A | 07 | |
| 22 | 1KS19CS080 | SAHANA S | 1 | A | A | A | A | A | A | A | 2 | A | A | A | A | A | 02 | |
| 23 | 1KS19CS081 | SAI SHIRISHA S B | 1 | 2 | 3 | 4 | 5 | A | 6 | 7 | 8 | 9 | 10 | 11 | A | A | 11 | |
| 24 | 1KS19CS082 | SANGHARSH KUMAR RAI | A | A | A | A | A | A | A | A | A | A | A | A | A | A | 00 | |
| 25 | 1KS19CS083 | SANJEEV MYSORE | A | A | A | A | A | A | A | A | 1 | A | A | A | A | A | 01 | |
| 26 | 1KS19CS084 | SANKALP KESTI | A | A | A | A | A | A | A | A | A | A | A | A | A | A | 00 | |
| 27 | 1KS19CS085 | SATISH V | 1 | 2 | A | A | A | A | 3 | 4 | 5 | 6 | 7 | A | A | 8 | A | 08 |
| 28 | 1KS19CS086 | SHANVI B P | 1 | 2 | 3 | 4 | 5 | A | 6 | 7 | 8 | 9 | A | A | A | A | 09 | |
| 29 | 1KS19CS087 | SHIVANI G K | A | A | A | A | A | A | 1 | 2 | A | A | A | A | A | A | 02 | |
| 30 | 1KS19CS088 | SHREESHA S | A | A | A | A | A | A | A | A | 1 | A | A | A | A | A | 01 | |
| 31 | 1KS19CS089 | SHREYA R KIRAN | A | A | A | A | A | A | 1 | 2 | A | 3 | A | A | A | A | 03 | |
| 32 | 1KS19CS090 | SHRI HARSHA S | A | A | A | A | A | A | A | A | A | A | A | A | A | A | 00 | |
| 33 | 1KS19CS091 | SINDHU S | 1 | 2 | A | A | A | A | A | A | 3 | 4 | A | A | A | A | 04 | |
| 34 | 1KS19CS092 | SMRITHI SHEKAR | A | A | A | A | A | A | 1 | 2 | 3 | 4 | A | A | A | A | 04 | |
| 35 | 1KS19CS093 | SRUJAN K | A | 1 | A | A | A | A | A | A | 2 | 3 | A | A | A | A | 03 | |
| 36 | 1KS19CS094 | SRUSTI S GOWDA | A | A | A | A | A | A | 1 | 2 | 3 | 4 | A | A | A | A | 04 | |
| 37 | 1KS19CS096 | SUHAS S | A | A | A | A | A | A | A | A | 1 | A | A | A | A | A | 01 | |
| 38 | 1KS19CS097 | SUSHMITHA K | 1 | 2 | A | 3 | A | A | 4 | 5 | 6 | 7 | A | A | A | A | 07 | |
| 39 | 1KS19CS098 | SWETHA M KULKARNI | 1 | A | A | A | A | A | 2 | 3 | A | 4 | A | A | A | A | 04 | |
| 40 | 1KS19CS099 | SYED ZAINUL ABIDIN | A | 1 | A | A | A | A | A | 2 | A | A | A | A | A | A | 02 | |
| 41 | 1KS19CS100 | TALLURU MAURYA | A | A | A | A | A | A | A | A | A | 1 | A | A | A | A | 01 | |
| 42 | 1KS19CS101 | TANUSHREE R | A | A | A | 1 | 2 | A | 3 | 4 | A | 5 | 6 | A | A | A | 06 | |

| | | | | | | | | | | | | | | | | | | | |
|--|------------|--------------------|--------------------|--------------------|--------------------|--------------------|--------------------|--------------------|--------------------|--------------------|--------------------|--------------------|--------------------|--------------------|--------------------|--------------------|--------------------|--------------------|--------------------|
| 43 | 1KS19CS102 | TEJAS N | A | A | A | 1 | A | A | A | A | A | 2 | A | A | A | A | A | 02 | 2 |
| 44 | 1KS19CS103 | TEJAS P | A | A | A | A | A | A | A | A | A | 1 | 2 | A | A | A | A | 02 | 1 |
| 45 | 1KS19CS104 | TEJASWINI NAYAKA S | 1 | 2 | A | 3 | A | A | A | 5 | 6 | 7 | A | A | A | A | A | 07 | 6 |
| 46 | 1KS19CS105 | THANUSHREE S | A | 1 | A | 2 | 3 | A | A | A | A | 4 | 5 | A | A | A | A | 05 | 3 |
| 47 | 1KS19CS106 | THIRUMAL R | A | 1 | A | A | A | A | A | A | A | A | A | A | A | A | A | 01 | 1 |
| 48 | 1KS19CS107 | THRIVENI U | 1 | 2 | 3 | 4 | 5 | A | 6 | 7 | 8 | 9 | 10 | A | A | A | A | 10 | 6 |
| 49 | 1KS19CS108 | UDHAY KUMAR G | A | A | A | A | A | A | A | A | A | A | A | A | A | A | A | 00 | 0 |
| 50 | 1KS19CS109 | VAISHNAVI G | A | A | A | A | A | A | A | A | A | A | A | A | A | A | A | 00 | 0 |
| 51 | 1KS19CS110 | VARSHA BAI R | 1 | 2 | A | 3 | 4 | A | A | A | A | 5 | 6 | A | 7 | A | A | 07 | 4 |
| 52 | 1KS19CS111 | VARUN KAMBALI | A | A | A | 1 | 2 | A | A | A | A | A | A | A | A | A | A | 02 | 2 |
| 53 | 1KS19CS112 | VISHAL GUPTA | A | A | A | A | A | A | 1 | 2 | A | A | A | A | A | A | A | 02 | 1 |
| 54 | 1KS19CS113 | YASHWANTH S R | A | 1 | A | A | A | A | A | A | A | 2 | 3 | 4 | A | A | A | 04 | 3 |
| 55 | 1KS19CS115 | AKSHAY R | A | A | A | A | A | A | 1 | 2 | A | 3 | A | A | A | A | A | 03 | 2 |
| 56 | 1KS18CS021 | G. SARAYU CHOWDARY | A | A | A | A | A | A | 1 | 2 | 3 | A | A | A | A | A | A | 03 | 2 |
| 57 | 1KS18CS068 | PRAJWAL N | A | A | A | A | A | A | A | 1 | A | A | A | A | A | A | A | 01 | 1 |
| 58 | 1KS20CS401 | ANUSHA A R | A | A | A | 1 | 2 | A | 3 | 4 | 5 | A | A | A | A | A | A | 05 | 3 |
| 59 | 1KS20CS403 | NITHIN S | 1 | 2 | A | A | 3 | A | A | 4 | A | A | 5 | 6 | A | A | A | 06 | 4 |
| No. of Students Absent | | | 39 | 43 | 54 | 39 | 45 | 59 | 31 | 27 | 42 | 32 | 44 | 56 | 54 | 58 | 59 | 07 | 1 |
| No. of Students Present | | | 20 | 16 | 05 | 20 | 14 | 00 | 28 | 32 | 17 | 37 | 15 | 03 | 05 | 01 | 00 | 52 | |
| Signature of trainer/Placement Coordinator | | | <i>[Signature]</i> | <i>[Signature]</i> | <i>[Signature]</i> | <i>[Signature]</i> | <i>[Signature]</i> | <i>[Signature]</i> | <i>[Signature]</i> | <i>[Signature]</i> | <i>[Signature]</i> | <i>[Signature]</i> | <i>[Signature]</i> | <i>[Signature]</i> | <i>[Signature]</i> | <i>[Signature]</i> | <i>[Signature]</i> | <i>[Signature]</i> | <i>[Signature]</i> |





K.S INSTITUTE OF TECHNOLOGY, BENGALURU

CONSOLIDATED ATTENDANCE FOR PDTP_2023 BATCH

ECE (A) - OB 106

| IV YEAR | | | VII SEMESTER | | | | | | | | | 'A' SECTION | | | | | TOTAL | |
|---------|------------|-----------------------------|--------------|---|---|------------|---|---|------------|---|---|-------------|----|----|------------|----|-------|----|
| S. No | USN | NAME OF THE STUDENT | Dates | | | | | | | | | | | | | | | |
| | | | 02/11/2022 | | | 03/11/2022 | | | 04/11/2022 | | | 07/11/2022 | | | 08/11/2022 | | | |
| | | | 1 | 2 | 3 | 4 | 5 | 6 | 7 | 8 | 9 | 10 | 11 | 12 | 13 | 14 | 15 | |
| 1 | 1KS19EC001 | ABHILASH A S | 1 | 2 | A | 3 | 4 | 5 | 6 | A | A | 7 | 8 | 9 | A | A | A | 09 |
| 2 | 1KS19EC002 | ABHISHEK CHANDRESH | 1 | 2 | A | 3 | 4 | A | 5 | 6 | 7 | 8 | 9 | 10 | 11 | 12 | 13 | 13 |
| 3 | 1KS19EC003 | AISHWARYA BASAVARAJ KEMBAVI | 1 | 2 | 3 | 4 | 5 | 6 | 7 | 8 | 9 | 10 | 11 | 12 | 13 | 14 | 15 | 15 |
| 4 | 1KS19EC004 | AISHWARYA M G | 1 | 2 | A | 3 | 4 | 5 | 6 | 7 | 8 | 9 | 10 | 11 | 12 | A | A | 12 |
| 5 | 1KS19EC005 | AKSHAY KUMAR D | 1 | A | A | 2 | 3 | 4 | 5 | 6 | 7 | A | 8 | A | 9 | 10 | 11 | 11 |
| 6 | 1KS19EC006 | AKSHITHA | 1 | 2 | 3 | 4 | 5 | 6 | 7 | 8 | 9 | 10 | 11 | A | 12 | A | A | 12 |
| 7 | 1KS19EC007 | AMRUTA | 1 | 2 | 3 | 4 | 5 | 6 | 7 | 8 | 9 | A | A | A | 10 | 11 | 12 | 12 |
| 8 | 1KS19EC008 | AMULYA R | A | A | A | 1 | 2 | A | A | A | A | 3 | 4 | 5 | 6 | 7 | 8 | 08 |
| 9 | 1KS19EC009 | ANITHA S | 1 | 2 | 3 | 4 | 5 | 6 | 7 | 8 | 9 | A | A | A | 10 | 11 | 12 | 12 |
| 10 | 1KS19EC010 | ANJALI Y J | 1 | 2 | A | 3 | 4 | 5 | 6 | 7 | 8 | 9 | 10 | 11 | 12 | 13 | 14 | 14 |
| 11 | 1KS19EC011 | ARCHANA YADAV M | 1 | 2 | 3 | 4 | 5 | 6 | 7 | 8 | 9 | 10 | 11 | 12 | A | A | A | 12 |
| 12 | 1KS19EC012 | ASHRITHA R | A | A | A | 1 | A | A | A | A | A | A | A | A | A | A | A | 01 |
| 13 | 1KS19EC014 | BHAVANA S | A | A | A | 1 | 2 | 3 | 4 | 5 | A | 6 | 7 | 8 | 9 | A | A | 09 |
| 14 | 1KS19EC015 | CHAITRA P | 1 | 2 | 3 | 4 | 4 | 5 | 6 | 7 | 8 | 9 | 10 | 11 | 12 | A | A | 12 |
| 15 | 1KS19EC016 | CHANDAN RAJ Y | 1 | 2 | A | A | A | A | A | A | A | 3 | 4 | 5 | 6 | 7 | 8 | 08 |
| 16 | 1KS19EC017 | CHANDANA.L | 1 | 2 | 3 | 4 | 5 | 6 | 7 | 8 | 9 | 10 | 11 | 12 | 13 | A | A | 13 |
| 17 | 1KS19EC018 | CHENNREDDY RAJASEKHAR | A | A | A | 1 | 2 | 3 | A | A | A | A | 4 | A | A | A | A | 04 |
| 18 | 1KS19EC019 | CHIRANTHANA YOGANANDA K | A | A | A | A | A | A | A | A | A | A | A | A | A | A | A | 00 |
| 19 | 1KS19EC020 | D NAYAN | A | 1 | A | A | 2 | 3 | 4 | A | A | 5 | 6 | 7 | 8 | 9 | A | 09 |
| 20 | 1KS19EC021 | DANESH RAJU V | A | 1 | A | 2 | 3 | 4 | 5 | 6 | 7 | 8 | 9 | A | 10 | A | A | 10 |
| 21 | 1KS19EC022 | DAVINO JOSEPH | A | A | A | 1 | 2 | A | A | A | A | 3 | 4 | 5 | 6 | A | A | 06 |
| 22 | 1KS19EC023 | DHANYA SUKANTH B K | A | A | A | A | A | A | 1 | 2 | 3 | 4 | 5 | 6 | 7 | 8 | 9 | 09 |
| 23 | 1KS19EC024 | DHEEMANTH K N | 1 | 2 | 3 | 4 | 5 | 6 | 7 | 8 | 9 | 10 | 11 | A | 12 | A | A | 12 |
| 24 | 1KS19EC025 | DISHA SHIVANI | A | A | A | 1 | 2 | 3 | 4 | 5 | 6 | 7 | 8 | 9 | 10 | 11 | 12 | 12 |
| 25 | 1KS19EC027 | GAYATHRI P K | A | A | A | 1 | A | 2 | 3 | 4 | 5 | 6 | 7 | A | 8 | 9 | 10 | 10 |
| 26 | 1KS19EC028 | GAYATHRI R WARRIER | A | A | A | 1 | 2 | 3 | 4 | 5 | 6 | 7 | 8 | 9 | 10 | 11 | 12 | 12 |
| 27 | 1KS19EC029 | GONUGUNTLA SAI SIDDARTHA | 1 | 2 | A | 3 | 4 | 5 | A | A | A | 6 | 7 | 8 | 9 | A | A | 09 |
| 28 | 1KS19EC030 | GOWRI S NADIGER | 1 | 2 | 3 | 4 | 5 | 6 | A | A | A | 7 | 8 | 9 | 10 | 11 | 12 | 12 |
| 29 | 1KS19EC031 | HARSHA R | A | A | A | A | A | A | 1 | 2 | A | A | A | A | A | A | A | 02 |
| 30 | 1KS19EC032 | HARSHITHA B Y | A | A | A | 1 | 2 | 3 | 4 | 5 | A | 6 | 7 | 8 | 9 | A | A | 09 |
| 31 | 1KS19EC033 | HEMANTH.R.PATIL | 1 | 2 | A | 3 | 4 | 5 | 6 | A | A | A | A | A | A | A | A | 06 |
| 32 | 1KS19EC035 | JAGRUTI PAI | A | A | A | 1 | 2 | 2 | 3 | 4 | 5 | 6 | 7 | 8 | 9 | 11 | 12 | 12 |
| 33 | 1KS19EC036 | JAYANTH M B | 1 | 2 | A | A | 3 | A | 4 | 5 | 6 | 7 | 8 | 9 | 10 | 11 | 12 | 12 |
| 34 | 1KS19EC037 | KAMMA MANUBOLU MANOGNA | 1 | 2 | 3 | 4 | 5 | 6 | 7 | 8 | 9 | 10 | 11 | A | 12 | 13 | A | 13 |
| 35 | 1KS19EC038 | KARTHIK K | A | A | A | A | A | A | A | A | A | A | A | A | A | A | A | 00 |
| 36 | 1KS19EC039 | KASHYAP.P | A | A | A | A | A | A | 1 | 2 | 3 | 4 | 5 | 6 | 7 | 8 | 9 | 09 |
| 37 | 1KS19EC040 | KRUPA.A | 1 | 2 | 3 | A | 4 | 5 | 6 | 7 | 8 | 9 | 10 | 11 | 12 | A | A | 12 |
| 38 | 1KS19EC041 | KRUTHIK S | 1 | A | A | 2 | 3 | 4 | 5 | 6 | 7 | 8 | 9 | 10 | 11 | 12 | 13 | 13 |
| 39 | 1KS19EC042 | LAKSHMAN KUMARA B | 1 | 2 | A | 3 | 4 | 5 | 6 | 7 | 8 | 9 | 10 | 11 | A | A | A | 11 |
| 40 | 1KS19EC043 | LIKITHA.H | 1 | 2 | 3 | A | 4 | 5 | 6 | 7 | 8 | 9 | 10 | 11 | 12 | A | A | 12 |
| 41 | 1KS19EC044 | M LOKESHWARI | 1 | 2 | 3 | 4 | 5 | 6 | 7 | 8 | 9 | 10 | 11 | A | 12 | A | A | 12 |
| 42 | 1KS19EC045 | MANU N KANDRA | 1 | 2 | 3 | 4 | 5 | 6 | 7 | 8 | 9 | 10 | 11 | A | 12 | 13 | A | 13 |

| | | | | | | | | | | | | | | | | | | |
|--|------------|----------------------|----|----|----|----|----|----|----|----|----|----|----|----|----|----|----|------|
| 43 | 1KS19EC046 | MEGHANA H P | A | A | A | 1 | 2 | 3 | 4 | 5 | 6 | 7 | 8 | 9 | 10 | A | A | 107 |
| 44 | 1KS19EC047 | MOHAMMAD RAKHEEB M R | A | A | A | A | A | A | 1 | 2 | 3 | 4 | 5 | A | A | A | A | 054 |
| 45 | 1KS19EC048 | MOHITH KUMAR G | 1 | 2 | 3 | 4 | 5 | 6 | 7 | 8 | 9 | 10 | 11 | A | 12 | A | 13 | 139 |
| 46 | 1KS19EC049 | MONIKA V ARYA | 1 | 2 | 3 | A | 4 | 5 | 6 | 7 | 8 | 9 | 10 | 11 | 12 | A | A | 129 |
| 47 | 1KS19EC050 | MONISHA.B.K | 1 | 2 | 3 | 4 | 5 | 6 | 7 | 8 | 9 | 10 | 11 | 12 | A | A | A | 128 |
| 48 | 1KS19EC051 | N ANILA | 1 | 2 | 3 | 4 | 5 | 6 | 7 | 8 | 9 | 10 | 11 | 12 | 13 | A | A | 139 |
| 49 | 1KS19EC052 | NIDHI S | A | A | A | A | A | A | A | A | A | A | A | A | A | A | A | (00) |
| 50 | 1KS19EC053 | NISARGA K | 1 | 2 | A | 3 | 4 | 5 | 6 | 7 | 8 | 9 | 10 | 11 | A | A | A | 117 |
| 51 | 1KS19EC054 | NITHIN D | 1 | 2 | A | A | A | A | A | A | A | A | A | A | A | A | A | 02 |
| 52 | 1KS19EC055 | PAVAN KUMAR G R | 1 | 2 | A | 3 | 4 | 5 | 6 | 7 | 8 | 9 | 10 | 11 | 12 | A | A | 128 |
| 53 | 1KS19EC056 | POKURI MOUNIKA | 1 | A | A | A | 2 | A | A | A | A | 3 | 4 | 5 | A | A | A | 054 |
| 54 | 1KS19EC057 | POOJA S P | 1 | 2 | 3 | 4 | 5 | 6 | A | A | A | 7 | 8 | 9 | 10 | 11 | 12 | 128 |
| 55 | 1KS19EC058 | PRADEEP GADED | A | A | A | A | A | A | A | A | A | A | A | A | A | A | A | (00) |
| 56 | 1KS19EC059 | PRAKASH CHEGORE | A | A | A | A | A | A | A | A | A | A | A | A | A | A | A | (00) |
| 57 | 1KS19EC061 | PRASHANTH.S.K | A | A | A | A | A | A | A | A | A | A | A | A | A | A | A | (00) |
| 58 | 1KS19EC062 | PRAVEEN KUMAR N | A | A | A | 1 | 2 | 3 | 4 | 5 | 6 | 7 | 8 | 9 | 10 | A | A | 107 |
| 59 | 1KS19EC063 | PREETHAM G H | 1 | 2 | A | A | A | A | 3 | 4 | 5 | 6 | 7 | A | A | A | A | 074 |
| 60 | 1KS19EC064 | PRIYANKA K | 1 | 2 | 3 | 4 | 5 | 6 | 7 | 8 | 9 | A | 10 | A | 11 | A | A | 118 |
| 61 | 1KS19EC065 | RADHA KRISHNA L | 1 | A | A | 2 | 3 | 4 | 5 | 6 | A | 7 | 8 | 9 | 10 | 11 | A | 118 |
| 62 | 1KS19EC066 | RAJALAKSHMI S | 1 | 2 | 3 | 4 | 5 | 6 | 7 | 8 | A | 9 | 10 | A | A | A | A | 118 |
| No. of Students Absent | | | 24 | 26 | 41 | 21 | 16 | 19 | 16 | 19 | 24 | 15 | 12 | 26 | 20 | 40 | 43 | (06) |
| No. of Students Present | | | 38 | 36 | 21 | 41 | 46 | 43 | 46 | 43 | 38 | 47 | 50 | 36 | 42 | 22 | 19 | 56 |
| Signature of trainer/Placement Coordinator | | | Ra | Ra | Ra | Ra | Ra | Ra | Ra | Ra | Ra | Ra | Ra | Ra | Ra | Ra | Ra | Ra |





K.S INSTITUTE OF TECHNOLOGY, BENGALURU

CONSOLIDATED ATTENDANCE FOR PDTP_2023 BATCH

ECE (B) + ETE - OB 007

| IV YEAR | | | VII SEMESTER | | | | | | 'B' SECTION | | | | | | | | | |
|---------|------------|-------------------------|--------------|---|---|------------|---|---|-------------|---|---|------------|----|----|------------|----|----|-------|
| S. No | USN | NAME OF THE STUDENT | Dates | | | | | | | | | | | | | | | TOTAL |
| | | | 02/11/2022 | | | 03/11/2022 | | | 04/11/2022 | | | 07/11/2022 | | | 08/11/2022 | | | |
| | | | 1 | 2 | 3 | 4 | 5 | 6 | 7 | 8 | 9 | 10 | 11 | 12 | 13 | 14 | 15 | |
| 1 | 1KS19EC067 | RAMYASREE R | A | A | A | 1 | 2 | 3 | 4 | 5 | 6 | A | A | A | A | A | A | 06 |
| 2 | 1KS19EC068 | RANGASWAMY.U | A | A | A | A | A | A | A | A | A | 1 | 2 | 3 | 4 | 5 | A | 05 |
| 3 | 1KS19EC069 | ROHAN K R | A | 1 | A | 2 | 3 | 4 | A | A | A | 5 | 6 | 7 | 8 | A | A | 08 |
| 4 | 1KS19EC070 | S K BHARATESH | 1 | 2 | A | 3 | 4 | 5 | 6 | 7 | 8 | 9 | 10 | 11 | 12 | 13 | A | 13 |
| 5 | 1KS19EC071 | SABARISH I J | 1 | 2 | 3 | 4 | 5 | 6 | 7 | 8 | 9 | 10 | 11 | A | 12 | 13 | 14 | 14 |
| 6 | 1KS19EC073 | SAHANA S | 1 | 2 | 3 | 4 | 5 | 6 | 7 | 8 | 9 | 10 | 11 | A | 12 | A | A | 12 |
| 7 | 1KS19EC074 | SAI PRIYA T S | 1 | 2 | A | 3 | 4 | A | 5 | 6 | A | 7 | 8 | A | A | A | A | 08 |
| 8 | 1KS19EC075 | SAMIKSHA S | 1 | 2 | 3 | 4 | 5 | 6 | 7 | 8 | 9 | A | 10 | 11 | 12 | A | A | 12 |
| 9 | 1KS19EC076 | SANTOSH HEGDE | 1 | 2 | A | 3 | 4 | 5 | 6 | 7 | 8 | 9 | 10 | A | 11 | 12 | 13 | 13 |
| 10 | 1KS19EC077 | SATHVIK U M | 1 | 2 | A | 3 | 4 | 5 | A | A | A | 6 | 7 | A | 8 | 9 | 10 | 10 |
| 11 | 1KS19EC078 | SHAMITHA BIJOOR | 1 | 2 | 3 | 4 | 5 | 6 | 7 | 8 | 9 | 10 | 11 | 12 | 13 | A | A | 13 |
| 12 | 1KS19EC079 | SHASHANK KASHYAP.H.R | 1 | 2 | 3 | 4 | 5 | 6 | A | 7 | 8 | A | 9 | A | 10 | 11 | 12 | 12 |
| 13 | 1KS19EC081 | SHREYAMS D K | 1 | 2 | 3 | 4 | 5 | 6 | 7 | 8 | A | A | 9 | 10 | A | 11 | 12 | 12 |
| 14 | 1KS19EC082 | SHREYAS B ARADHYA | 1 | 2 | A | 3 | 4 | 5 | 6 | 7 | 8 | 9 | 10 | 11 | 12 | 13 | A | 13 |
| 15 | 1KS19EC083 | SHREYAS GOWDA | 1 | 2 | 3 | 4 | A | 5 | 6 | 7 | A | A | 8 | 9 | 10 | 11 | A | 11 |
| 16 | 1KS19EC084 | SHREYAS V BHARADWAJ | 1 | 2 | 3 | A | 4 | 5 | 6 | 7 | 8 | 9 | A | A | 10 | 11 | A | 11 |
| 17 | 1KS19EC085 | SHUBHAM KUMAR SINGH A | 1 | A | A | A | A | 2 | 3 | 4 | 5 | A | 6 | 7 | 8 | 9 | A | 09 |
| 18 | 1KS19EC086 | SINCHANA M N | 1 | 2 | 3 | 4 | 5 | 6 | 7 | 8 | 9 | 10 | 11 | 12 | 13 | A | A | 13 |
| 19 | 1KS19EC087 | SRINIVAS S | 1 | 2 | 3 | 4 | 5 | 6 | 7 | 8 | 9 | A | 10 | 11 | 12 | 13 | A | 13 |
| 20 | 1KS19EC088 | SRINIVASAN M | 1 | 2 | A | 3 | 4 | 5 | 6 | 7 | 8 | 9 | 10 | A | 11 | 12 | A | 12 |
| 21 | 1KS19EC089 | SRIRAM | 1 | 2 | 3 | A | A | A | A | A | A | 4 | 5 | 6 | 7 | 8 | A | 08 |
| 22 | 1KS19EC090 | SUHAS.M | A | A | A | 1 | A | A | A | A | A | A | A | 2 | 3 | 4 | 04 | |
| 23 | 1KS19EC092 | SUMUKHA VASISHTA M R | 1 | 2 | 3 | 4 | 5 | 6 | A | A | A | 7 | 8 | 9 | 10 | 11 | 12 | 12 |
| 24 | 1KS19EC093 | SUSHMITHA S | 1 | 2 | 3 | 4 | 5 | 6 | 7 | 8 | 9 | 10 | 11 | 12 | 13 | A | A | 13 |
| 25 | 1KS19EC094 | SWAGATH AITHAL P G | A | 1 | 2 | A | 3 | 4 | 5 | 6 | 7 | 8 | 9 | A | 10 | 11 | 12 | 12 |
| 26 | 1KS19EC095 | SWATHI U | 1 | 2 | 3 | 4 | 5 | 6 | 7 | 8 | A | 9 | 10 | 11 | A | A | A | 11 |
| 27 | 1KS19EC096 | T N L RUTHVIK | A | 1 | 2 | 3 | 4 | 5 | 6 | 7 | 8 | 9 | 10 | A | 11 | 12 | 13 | 13 |
| 28 | 1KS19EC097 | TEJASHWINI P V | 1 | 2 | A | 3 | 4 | A | A | A | A | 5 | 6 | A | A | A | A | 06 |
| 29 | 1KS19EC098 | THEERTHANA S R | 1 | 2 | 3 | 4 | 5 | 6 | 7 | 8 | 9 | A | 10 | 11 | 12 | A | A | 12 |
| 30 | 1KS19EC099 | TUSHAR R VASISHTA | A | A | A | A | A | 1 | 2 | 3 | 4 | 5 | 6 | 7 | A | A | A | 07 |
| 31 | 1KS19EC100 | VAISHNAVI K | 1 | 2 | 3 | 4 | 5 | 6 | 7 | 8 | 9 | 10 | 11 | 12 | 13 | A | A | 13 |
| 32 | 1KS19EC101 | VANDANA G | 1 | 2 | 3 | 4 | 5 | 6 | A | A | A | 7 | 8 | 9 | 10 | A | A | 10 |
| 33 | 1KS19EC102 | VANDANA S | 1 | 2 | 3 | 4 | 5 | 6 | 7 | 8 | A | 9 | 10 | 11 | 12 | A | A | 12 |
| 34 | 1KS19EC103 | VIGNESH MUTHAIAH R | 1 | 2 | 3 | 4 | 5 | A | 6 | 7 | A | 8 | 9 | 10 | 11 | 12 | A | 12 |
| 35 | 1KS19EC104 | VIKAS S | A | A | A | A | A | A | 1 | 2 | 3 | 4 | 5 | 6 | A | A | A | 06 |
| 36 | 1KS19EC105 | VINUTH S REDDY | A | A | A | 1 | A | A | 2 | 3 | A | A | 4 | 5 | 6 | 7 | A | 07 |
| 37 | 1KS19EC106 | VISHAL SANJAY RAJU | A | A | A | 1 | 2 | A | 3 | 4 | 5 | A | 6 | 7 | A | A | A | 07 |
| 38 | 1KS19EC107 | VISHNU RAATA YADUNANDAN | A | A | A | 1 | 2 | 3 | A | A | 4 | 5 | 6 | A | A | A | A | 06 |
| 39 | 1KS19EC108 | YASHASWINI N | 1 | 2 | 3 | 4 | A | A | 5 | 6 | A | A | A | A | A | A | A | 06 |
| 40 | 1KS18EC089 | SNEHA N | 1 | 2 | A | 3 | 4 | 5 | 6 | 7 | A | 8 | 9 | A | 10 | A | A | 10 |
| 41 | 1KS20EC400 | MADALA VIVEK KUMAR | 1 | A | A | A | 2 | 3 | 4 | 5 | A | A | A | A | 6 | A | A | 06 |
| 42 | 1KS20EC401 | RANJANA P | A | 1 | 2 | 3 | 4 | 5 | A | 6 | A | A | 7 | 8 | A | A | A | 08 |

| | | | | | | | | | | | | | | | | | | | |
|--|------------|------------------------|--------------------|--------------------|--------------------|--------------------|--------------------|--------------------|--------------------|--------------------|--------------------|--------------------|--------------------|--------------------|--------------------|--------------------|--------------------|--------------------|---|
| 43 | 1KS20EC402 | SINDHU J | A | A | A | A | A | A | 1 | 2 | 3 | A | 4 | 5 | A | A | A | 05 | 4 |
| 44 | 1KS18TE005 | ANKITHA . N | A | 1 | A | A | 2 | 3 | A | 4 | A | 5 | 6 | 7 | A | A | A | 07 | 6 |
| 45 | 1KS19ET002 | CHAITRA C | 1 | 2 | 3 | 4 | 5 | 6 | 7 | 8 | 9 | A | A | A | A | A | A | 09 | 6 |
| 46 | 1KS19ET003 | LITCHITHA M GOWDA | A | A | A | A | A | A | 1 | 2 | A | A | A | A | A | A | A | 02 | 1 |
| 47 | 1KS19ET004 | MAHADEV A C | A | A | A | 1 | 2 | A | 3 | A | A | 4 | 5 | A | A | A | A | 05 | 3 |
| 48 | 1KS19ET005 | MRUTHYUNJAYA GUDIBANDE | A | A | A | 1 | 2 | A | 3 | 4 | A | 5 | 6 | A | A | A | A | 06 | 3 |
| 49 | 1KS19ET006 | N NELBIN | A | A | 1 | 2 | 3 | A | 4 | A | A | 5 | 6 | A | A | A | A | 06 | 4 |
| 50 | 1KS19ET007 | NIRANJAN S RAO | A | A | A | 1 | 2 | A | 3 | A | A | 4 | 5 | A | A | A | A | 05 | 3 |
| 51 | 1KS19ET008 | RISHI KUMAR S | A | A | A | A | A | A | 1 | A | A | 2 | 3 | A | A | A | A | 03 | 2 |
| 52 | 1KS19ET009 | ROHIT KUMAR | A | A | A | A | A | A | A | A | A | A | A | A | A | A | A | (60) | 0 |
| 53 | 1KS19ET010 | SHREYAS C R | A | A | A | A | A | A | 1 | 2 | 3 | 4 | 5 | 6 | A | A | A | 06 | 4 |
| 54 | 1KS19ET011 | SHWETHA K | 1 | 2 | 3 | 4 | 5 | 6 | 7 | 8 | 9 | 10 | 11 | A | A | A | A | 11 | 7 |
| 55 | 1KS19ET012 | VAISHNAVI S | A | A | A | 1 | 2 | 3 | 4 | 5 | A | A | A | A | A | A | A | 05 | 3 |
| No. of Students Absent | | | 23 | 20 | 29 | 14 | 14 | 19 | 13 | 14 | 28 | 20 | 09 | 27 | 24 | 35 | 46 | (61) | |
| No. of Students Present | | | 32 | 35 | 26 | 41 | 41 | 36 | 42 | 41 | 27 | 35 | 46 | 28 | 31 | 20 | 09 | 54 | |
| Signature of trainer/Placement Coordinator | | | <i>[Signature]</i> | <i>[Signature]</i> | <i>[Signature]</i> | <i>[Signature]</i> | <i>[Signature]</i> | <i>[Signature]</i> | <i>[Signature]</i> | <i>[Signature]</i> | <i>[Signature]</i> | <i>[Signature]</i> | <i>[Signature]</i> | <i>[Signature]</i> | <i>[Signature]</i> | <i>[Signature]</i> | <i>[Signature]</i> | <i>[Signature]</i> | |





K.S INSTITUTE OF TECHNOLOGY, BENGALURU

CONSOLIDATED ATTENDANCE FOR PDTP_2023 BATCH

ME - OB 008

| IV YEAR | | | VII SEMESTER | | | | | | | | | | | | | | | |
|---------|------------|------------------------|--------------|---|---|------------|---|---|------------|---|---|------------|----|----|------------|----|----|-------|
| S. No | USN | NAME OF THE STUDENT | Dates | | | | | | | | | | | | | | | TOTAL |
| | | | 02/11/2022 | | | 03/11/2022 | | | 04/11/2022 | | | 07/11/2022 | | | 08/11/2022 | | | |
| | | | 1 | 2 | 3 | 4 | 5 | 6 | 7 | 8 | 9 | 10 | 11 | 12 | 13 | 14 | 15 | |
| 1 | 1KS19ME001 | ACHINTYA S SAROVAR | A | A | A | 1 | 2 | A | 3 | 4 | 5 | 6 | 7 | 8 | 9 | 10 | 11 | 11 |
| 2 | 1KS19ME002 | ADVAIT SIDDANTH K V | A | A | A | A | A | A | A | A | A | A | A | A | A | A | A | 00 |
| 3 | 1KS19ME003 | AJITH KUMAR R | 1 | A | 2 | 3 | 4 | 5 | 6 | 7 | 8 | 9 | 10 | 11 | 12 | 13 | 14 | 14 |
| 4 | 1KS19ME004 | ARUN KUMAR M | 1 | 2 | 3 | A | A | A | 4 | 5 | A | 6 | 7 | 8 | 9 | 10 | 11 | 11 |
| 5 | 1KS19ME005 | BHAVAN KASHYAP K | A | A | A | A | A | A | A | A | 1 | 2 | 3 | 4 | 5 | A | 05 | |
| 6 | 1KS19ME008 | CHARITHA S | 1 | 2 | 3 | A | A | A | 4 | 5 | A | 6 | 7 | 8 | 9 | 10 | 11 | 11 |
| 7 | 1KS19ME009 | DARSHAN N | A | A | A | A | A | A | A | A | 1 | A | A | A | A | A | 01 | |
| 8 | 1KS19ME010 | DHANUSH GOWDA M | 1 | 2 | A | 3 | A | A | 4 | 5 | A | 6 | 7 | A | A | A | 07 | |
| 9 | 1KS19ME011 | HEMANTH K | A | A | A | A | A | A | 1 | 2 | 3 | A | A | A | A | A | 03 | |
| 10 | 1KS19ME013 | JASHWANTH S | 1 | 2 | 3 | 4 | A | A | 5 | 6 | A | 7 | 8 | 9 | 10 | 11 | 12 | 12 |
| 11 | 1KS19ME014 | JAYANTH T K | 1 | 2 | A | 3 | A | A | A | A | 4 | 5 | A | 6 | A | A | 06 | |
| 12 | 1KS19ME015 | JEEVAN B S | 1 | 2 | A | 3 | A | A | 4 | 5 | 6 | 7 | 8 | 9 | 10 | A | A | 10 |
| 13 | 1KS19ME016 | JITHAN A | 1 | 2 | 3 | 4 | 5 | 6 | 7 | 8 | 9 | 10 | 11 | 12 | 13 | 14 | 15 | 15 |
| 14 | 1KS19ME017 | MADHU V | 1 | 2 | A | 3 | 4 | A | 5 | 6 | 7 | 8 | 9 | 10 | 11 | 12 | 13 | 13 |
| 15 | 1KS19ME018 | MANUKUMAR D K | A | 1 | A | 2 | A | A | 3 | 4 | 5 | 6 | 7 | 8 | A | A | A | 08 |
| 16 | 1KS19ME019 | NIHAL M L | 1 | 2 | A | 3 | 4 | 5 | 6 | 7 | 8 | 9 | 10 | 11 | 12 | 13 | A | 13 |
| 17 | 1KS19ME020 | NITHESH S R | 1 | 2 | A | 3 | A | A | 4 | 5 | 6 | 7 | 8 | 9 | A | 10 | 11 | 11 |
| 18 | 1KS19ME021 | PRAJWAL KUMAR R | A | A | A | 1 | A | A | 2 | 3 | 4 | 5 | 6 | A | 7 | A | A | 07 |
| 19 | 1KS19ME022 | PRASANNA KUMAR S G | A | A | A | 1 | A | A | A | 2 | 3 | 4 | 5 | A | A | A | A | 05 |
| 20 | 1KS19ME023 | PRATHAP REDDY T M | A | A | A | A | A | A | A | A | 1 | 2 | A | A | A | A | 02 | |
| 21 | 1KS19ME024 | R DEEPAK A RAO | A | 1 | A | 2 | A | A | 3 | 4 | A | 5 | 6 | 7 | 8 | A | A | 08 |
| 22 | 1KS19ME025 | R MANOJ REDDY | 1 | 2 | A | 3 | A | A | 4 | 5 | A | 6 | 7 | 8 | 9 | 10 | A | 10 |
| 23 | 1KS19ME026 | RAHUL R | 1 | 2 | A | 3 | A | A | 4 | 5 | 6 | 7 | A | 8 | 9 | 10 | A | 10 |
| 24 | 1KS19ME027 | RAKSHITH NAGESH | A | 1 | A | 2 | A | A | 3 | 4 | A | A | A | 5 | A | A | 05 | |
| 25 | 1KS19ME028 | RAMACHANDRA S | A | A | A | A | A | A | 1 | 2 | 3 | 4 | A | 5 | 6 | 7 | A | 07 |
| 26 | 1KS19ME029 | SANJAY.V | A | A | A | 1 | 2 | A | 3 | 4 | A | 5 | 6 | 7 | 8 | 9 | 10 | 10 |
| 27 | 1KS19ME030 | SHREYAS B | A | A | A | A | A | A | A | A | 1 | A | A | A | A | A | 01 | |
| 28 | 1KS19ME031 | SHREYAS H VASIST | A | A | A | A | A | A | A | A | A | A | A | A | A | A | 00 | |
| 29 | 1KS19ME032 | SRIKRISHNA SANTHOSH K | 1 | 2 | A | 3 | A | A | 4 | 5 | A | 6 | 7 | 8 | 9 | A | 09 | |
| 30 | 1KS19ME033 | SUJAY ADITHYA | 1 | 2 | A | 3 | A | A | A | A | A | 4 | 5 | A | 6 | A | A | 06 |
| 31 | 1KS19ME034 | SYED ASMA ASHEER | 1 | 2 | A | 3 | A | A | 4 | 5 | 6 | 7 | A | 8 | 9 | 10 | A | 10 |
| 32 | 1KS19ME035 | THEJAS V R | A | A | A | A | A | A | A | A | 1 | A | A | A | A | A | 01 | |
| 33 | 1KS19ME036 | TILAK P | A | 1 | A | 2 | A | A | 3 | 4 | A | 5 | 6 | 7 | 8 | 9 | 10 | 10 |
| 34 | 1KS19ME037 | VAISHNAV H | 1 | 2 | 3 | 4 | A | A | A | A | A | 5 | 6 | 7 | A | 8 | 9 | 09 |
| 35 | 1KS19ME039 | VENKATRAMANA G BHAT | 1 | 2 | 3 | 4 | A | A | 5 | 6 | A | 7 | 8 | 9 | 10 | 11 | 12 | 12 |
| 36 | 1KS19ME040 | ZAFFAR ABDULLAH SHEIKH | A | A | A | A | A | A | A | A | A | A | A | A | A | A | A | 00 |
| 37 | 1KS18ME001 | ABHISHEK MANIKUMAR | A | 1 | A | A | A | A | 2 | 3 | 4 | 5 | 6 | 7 | 8 | A | A | 08 |
| 38 | 1KS18ME008 | ANUSH S | A | 1 | A | A | A | A | 2 | A | 3 | 4 | 5 | 6 | 7 | A | A | 07 |
| 39 | 1KS18ME010 | ATIF MANSOOR SHAIK | A | 1 | A | A | A | A | A | 2 | A | 3 | 4 | A | A | A | A | 04 |
| 40 | 1KS18ME024 | KARTHIK G S | A | 1 | A | A | A | A | A | 2 | A | 3 | 4 | A | A | A | A | 04 |
| 41 | 1KS18ME048 | PRAJWAL NIKAM | A | 1 | A | 2 | 3 | 4 | A | 5 | 6 | A | A | 7 | A | A | 8 | 08 |
| 42 | 1KS18ME056 | ROHITH S | 1 | 2 | A | 3 | 4 | 5 | 6 | 7 | 8 | 9 | 10 | 11 | 12 | 13 | A | 13 |

AXIS BANK LTD
JPNAGAR 6TH PHASE BANAGLORE (K, BENGALURU, 560078)
IFS CODE - UTIB0001513

A/c. PAYEE ONLY

VALID FOR THREE MONTHS FROM THE DATE OF ISSUE

DATE 08/11/2022
दिनांक D D M M Y Y Y Y

Pay Bizotic Talent Solutions Pvt Ltd OR BEARER / या धारक को

रुपये Rupees Fifty two thousand one hundred

₹ 52,100/- अदा करें

A/C NO. 912010014093916

PLTRS 000160

For K S INSTITUTE OF TECHNOLOGY

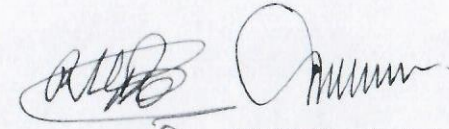

Authorised Signatory(ies)

Please sign above

Payable at par at all branches of Axis Bank Ltd in India.

⑈ 224435⑈ 560211034⑈ 000160⑈ 31

Received on 24/11/22



SESHAASAI (M) CTS 2010 22.07.2022 5144872



KSIT
K.S. INSTITUTE OF TECHNOLOGY

Kammavari Sangham (R) 1952
K.S. GROUP OF INSTITUTIONS

ಕೆ.ಎಸ್. ತಾಂತ್ರಿಕ ಮಹಾವಿದ್ಯಾಲಯ

K.S. INSTITUTE OF TECHNOLOGY

Accredited By NAAC

14, Raghuvanahalli, Kanakapura Road, Bengaluru - 560 109.

Tel : 080 28435722 / 24, Fax : 080 28435723

E-mail : principal.ksit@gmail.com / principal@ksit.edu.in | website : www.ksit.edu.in

Ref: KSIT/PO/2022-2023/TPO 004

Date: 23/09/2022

To,
Bizotic Talent Solutions Pvt Ltd.
#15, 3rd Main, 3rd Cross, Maruthi Nagar, Shreyas Colony
J P Nagar 7th Phase, Bengaluru - 560078

Dear Sir,

Sub: Purchase Order for NTT Data Company Specific Training for BE 2023 Batch Students.

With reference to the above, we are pleased to place the order for NTT Data Company Specific Training for final Year BE Students at K.S. Institute of Technology, #14, Raghuvanahalli, Kanakapura Road, Bangalore – 109 as per the following specifications, terms & conditions.

Programme Commercials:

| SL.No. | Description | Quantity | Rate | Amount |
|---|---|----------|---|-----------------|
| 1 | NTT Data Company Specific Training for BE 2023 Batch Students | 134 | Rs. 20/Hour/Student (134 × 18Hrs × 20Rs) | 48240/- |
| | Total | | | 48240/- |
| | Taxable Value | | | 48240/- |
| | ADD: CGST 9% | | | 4342/- |
| | ADD: SGST 9% | | | 4342/- |
| | Grand TOTAL | | | 56,924/- |
| Amount in Words: Rupees Fifty Six Thousand Nine Hundred and Twenty Four Only | | | | |

Terms & Conditions:

- Training dates for 7th Semester students would be from 26th - 28th September 2022.
- Company specific Mock Test to be conducted between 1st to 11th October 2022 in three sets
- Full Payment to be made post satisfactory completion of the training.

Thanking you,

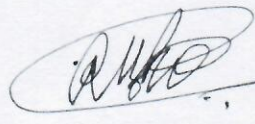
07/11/22
Hon. Secretary

KAMMAVARI SANGHAM

K.S. INSTITUTE OF TECHNOLOGY

Approved by AICTE New Delhi & Affiliated to VTU, Belagavi, Karnataka

TAX INVOICE





BIZOTIC TALENT SOLUTIONS PRIVATE LIMITED

#15, 3rd Main, 3rd Cross, Maruthi Nagar, Shreyas Colony

J P Nagar 7th Phase, Bengaluru - 560078

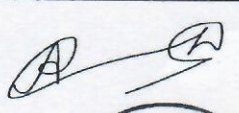
GSTIN No. 29AAGCB3936K1ZB

| Bill to | Place of Supply | INVOICE No | Dated | |
|---|--|------------------|--|--------|
| K.S. Institute of Technology #14, Raghuvanahalli, Kanakapura Road Bengaluru - 560109 GSTIN No | K.S. Institute of Technology #14, Raghuvanahalli, Kanakapura Road Bengaluru - 560109 | 2022-23/46 | 07-Oct-22 | |
| COMMENTS: | | | | |
| DESCRIPTION OF SERVICES | RATE DESCRIPTION | | SAC CODE | AMOUNT |
| Campus Alliance Program - NTT Data Company Specific Training for 7th Semester Engineering students - 2023 BATCH | No. of Students | Rate per Student | 999293 | 48240 |
| | 134 | 360 | | |
| TOTAL | | | | 48240 |
| Taxable Value | | | | 48240 |
| ADD: CGST 9% | | | | 4342 |
| ADD: SGST 9% | | | | 4342 |
| TOTAL | | | | 56924 |
| Amount (in words) | | | | |
| Rupees Fifty Six Thousand Nine Hundred and Twenty Four Only | | | FOR BIZOTIC TALENT SOLUTIONS PRIVATE LIMITED | |
| Cheques/DD Payable To: BIZOTIC TALENT SOLUTIONS PRIVATE LIMITED | | | Authorised Signatory | |
| Our Bank details for RTGS / NEFT Transfer | | |   | |
| Bank | HDFC BANK | | | |
| Branch | J P NAGAR 5th PHASE, BANGALORE | | | |
| Account Number | 50200012222162 | | | |
| Type of Account | CURRENT ACCOUNT | | | |
| IFSC Code | HDFC0003824 | | | |
| Company PAN | AAGCB3936K | | | |
| Tax may be deducted at Source @ 10% under section 194J of the Income Tax Act, 1961. Tax should not be deducted on the GST component charged on the invoice as per Circular No. 23 of 2017 dated 19th July 2017 issued by the Central Board of Direct Taxes, Ministry of Finance, Govt of India. | | | | |

WE THANK YOU FOR YOUR CONTINUED PATRONAGE WITH US

28/10/22
 PRINCIPAL
 K.S. INSTITUTE OF TECHNOLOGY
 BANGALURU - 560 109.

09/11/22



K.S INSTITUTE OF TECHNOLOGY

#14, Raghuvanahalli, Kanakapura Main Road, Bengaluru - 560109

Phone: 080-28435722/24 website: www.ksit.ac.in

**** DEPARTMENT OF TRAINING AND PLACEMENTS ****

23.09.2022

REVISED CIRCULAR

NTT DATA COMPANY SPECIFIC TRAINING PROGRAM FOR 2023 BATCH

Placement department have planned to conduct **NTT DATA company specific training program** for 2023 batch students from 26th to 28th September 2022. All eligible students are informed to attend the training program without fail. All HOD's are hereby informed to communicate their final year students regarding the same. All **placement coordinators** are requested to attend the same. Department wise scheduled is given below for your reference.

| Date | Time | BATCH 1 | BATCH 2 |
|--|-------------------|--------------------|--------------------|
| | | CSE (NB SH 204) | ECE (NB SH 403) |
| 26 th to 28 th September 2022 | 9:00 AM – 11:00AM | Trainer 1 | Trainer 2 |
| | 11:00AM – 11:15AM | BREAK | |
| | 11:15 AM – 1:15PM | Trainer 2 | Trainer 1 |
| | 1:15PM – 1:55PM | LUNCH BREAK | |
| | 2:00PM – 4:00PM | Trainer 1 | Trainer 2 |

NOTE:

1. All eligible students are informed to attend the training compulsory.
2. Students are strictly informed to be present in their allocated rooms only for all days.
3. Placement dress code compulsory.
4. Unregistered students are informed to attend their regular classes without fail.



(Handwritten Signature)

PRINCIPAL

PRINCIPAL

K.S. INSTITUTE OF TECHNOLOGY
BENGALURU - 560 109.

CC TO:

HODs and Coordinators of:

| | |
|------------------------|------------------------|
| CSE <i>(Signature)</i> | ECE <i>(Signature)</i> |
|------------------------|------------------------|

(Handwritten Signatures)
ME TCE
(Signature) *(Signature)*

TRAINING MODLULE FOR NTT DATA COMPANY SPECIFIC TRAINING

| Batch | 26.09.2022 - Monday | | |
|----------------|---------------------|---------------------|---------------------|
| | 9:00 am to 11:00 am | 11:15 am to 1:15 pm | 2:00 pm to 4:00 pm |
| Batch 1 CSE | Technical | Aptitude 1 | Technical |
| Batch 2 ECE | Aptitude 1 | Technical | Logical Reasoning 1 |

| Batch | 27.09.2022 - Tuesday | | |
|----------------|---|---------------------|--------------------|
| | 9:00 am to 11:00 am | 11:15 am to 1:15 pm | 2:00 pm to 4:00 pm |
| Batch 1 CSE | 9 am to 12:15 pm- Verbal 1 12:15 pm to 1:15 pm- Aptitude 2 | | Aptitude 2 |
| Batch 2 ECE | 9 am to 12:15 pm- Aptitude 2 12:15 pm to 1:15 pm- Verbal 1 | | Verbal 1 |

| Batch | 28.09.2022 - Wednesday | | |
|----------------|------------------------|---------------------|---------------------|
| | 9:00 am to 11:00 am | 11:15 am to 1:15 pm | 2:00 pm to 4:00 pm |
| Batch 1 CSE | Logical Reasoning 1 | Technical | Logical Reasoning 2 |
| Batch 2 ECE | Technical | Logical Reasoning 2 | Technical |



TRAINING TIMETABLE

Time Table for Batch 1

| Sl. No. | Date | Day | Duration | Topic | Trainer |
|---------|----------|--------------|-----------|-----------------------|--------------------|
| 1 | 26-09-22 | Monday | 4 | Technical | Vedavathi |
| 2 | | | 2 | Quantitative Aptitude | Shashank |
| 3 | 27-09-22 | Tuesday | 3 | Verbal | Srinath Sheturaman |
| 4 | | | 3 | Quantitative Aptitude | Vineet Mann |
| 5 | 28-09-22 | Wednesday | 4 | Logical Reasoning | Vineet Mann |
| 6 | | | 2 | Technical | Vedavathi |
| | | Total | 18 | | |



TRAINING TIMETABLE

Time Table for Batch 2

| Sl. No. | Date | Day | Duration | Topic | Trainer |
|---------|----------|--------------|-----------|-----------------------|--------------------|
| 1 | 26-09-22 | Monday | 4 | Quantitative Aptitude | Shashank |
| 2 | | | 2 | Technical | Vedavathi |
| 4 | 27-09-22 | Tuesday | 3 | Quantitative Aptitude | Vineet Mann |
| 5 | | | 3 | Verbal | Srinath Sheturaman |
| 7 | 28-09-22 | Wednesday | 4 | Technical | Vedavathi |
| 8 | | | 2 | Logical Reasoning | Vineet Mann |
| | | Total | 18 | | |





K.S INSTITUTE OF TECHNOLOGY, BENGALURU

DEPARTMENT OF TRAINING AND PLACEMENTS

ATTENDANCE FOR NTT DATA COMPANY SPECIFIC TRAINING (BATCH 1) - NB SH 204

| IV YEAR | | | VII SEMESTER | | | | | | | | | |
|---------|------------|---------------------|--------------|---|---|------------|---|---|------------|---|---|---------------|
| S. No | USN | NAME OF THE STUDENT | Dates | | | | | | | | | Total (09) |
| | | | 26/09/2022 | | | 27/09/2022 | | | 28/09/2022 | | | |
| | | | 1 | 2 | 3 | 4 | 5 | 6 | 7 | 8 | 9 | |
| 1 | 1KS19CS036 | INDRAJITH H M | 1 | 2 | 3 | 4 | 5 | 6 | 7 | 8 | 9 | 9 |
| 2 | 1ks19cs040 | Kalyan chowdhary b | 1 | 2 | A | A | A | A | A | A | A | 2 |
| 3 | 1KS19CS097 | Sushmitha K | 1 | A | A | A | A | A | 2 | 3 | A | 3 |
| 4 | 1KS19CS020 | C N Shreyas | 1 | 2 | 3 | 4 | 5 | A | 6 | 7 | 8 | 8 |
| 5 | 1KS19CS080 | Sahana.S | 1 | 2 | A | A | A | A | A | A | A | 2 |
| 6 | 1KS19CS026 | Devi Prasad N | 1 | 2 | A | 3 | 4 | A | A | A | A | 4 |
| 7 | 1KS19CS075 | Rv Yashvanth | 1 | A | A | A | A | A | A | A | A | 1 |
| 8 | 1KS19CS116 | Vrathika Billava | 1 | 2 | A | 3 | 4 | A | 5 | 6 | 7 | 7 |
| 9 | 1KS19CS009 | Amit K B | 1 | 2 | 3 | 4 | 5 | A | 6 | 7 | 8 | 8 |
| 10 | 1KS19CS074 | Puvan Kumar V | A | A | A | A | A | A | A | A | A | (A) |
| 11 | 1KS19CS060 | Neelamma Sali | 1 | 2 | A | A | A | A | A | A | A | 2 |
| 12 | 1KS19CS077 | Rakesh M J | A | A | A | A | A | A | A | A | A | (A) |
| 13 | 1KS19CS112 | Vishal Gupta | 1 | A | A | A | A | A | A | A | A | 1 |
| 14 | 1KS19CS070 | Prajwal Kulkarni | 1 | 2 | 3 | A | A | A | A | A | A | 3 |
| 15 | 1KS19CS083 | Sanjeev Mysore | A | A | A | 1 | 2 | A | A | A | A | 2 |
| 16 | 1KS19CS091 | Sindhu S | 1 | A | A | A | A | A | A | A | A | 1 |
| 17 | 1KS19CS089 | Shreya Kiran | 1 | A | A | 2 | A | A | A | A | A | 2 |
| 18 | 1KS19CS058 | NP Shashanka Rao | A | A | A | 1 | 2 | A | 3 | 4 | A | 4 |
| 19 | 1KS19CS107 | Thriveni U | 1 | 2 | A | 3 | 4 | A | 5 | 6 | A | 6 |
| 20 | 1KS19CS087 | Shivani. G. K | 1 | A | A | 2 | A | A | A | A | A | 2 |
| 21 | 1KS19CS085 | SATISH V | 1 | 2 | 3 | 4 | 5 | A | 6 | 7 | 8 | 8 |
| 22 | 1KS19CS102 | Tejas.n | 1 | A | A | A | A | A | A | A | A | 1 |
| 23 | 1KS19CS081 | Sai Shirisha S B | 1 | 2 | 3 | 4 | 5 | 6 | 7 | 8 | 9 | 9 |
| 24 | 1KS19CS052 | Manasa G L | 1 | 2 | A | 3 | 4 | A | A | A | A | 4 |
| 25 | 1KS19CS104 | Tejaswini Nayaka S | 1 | A | A | A | A | A | 2 | 3 | A | 3 |
| 26 | 1KS19CS035 | Harshitha J | 1 | A | A | 2 | 3 | A | 4 | A | A | 4 |
| 27 | 1KS19CS017 | Bhoomika AM | 1 | 2 | A | A | 3 | 4 | 5 | 6 | 7 | 7 |
| 28 | 1KS19CS099 | Syed Zain | 1 | 2 | A | 3 | 4 | 5 | A | A | A | 5 |

| | | | | | | | | | | | | |
|----|------------|-----------------------|---|---|---|---|---|---|---|---|---|-----|
| 29 | 1KS19CS069 | Prajwal G | 1 | 2 | 3 | 4 | 5 | A | 6 | 7 | A | 7 |
| 30 | 1KS19CS019 | Bhumika M | 1 | 2 | 3 | 4 | 5 | 6 | A | A | A | 6 |
| 31 | 1KS19CS071 | Preethi K P | 1 | 2 | A | 3 | 4 | A | 5 | 6 | A | 6 |
| 32 | 1KS19CS012 | Anagha A Hebbar | 1 | 2 | A | A | A | A | A | A | A | 2 |
| 33 | 1KS19CS094 | Srusti S Gowda | A | A | A | A | A | A | A | A | A | (A) |
| 34 | 1KS19CS049 | Lisha C | A | A | A | A | A | A | A | A | A | (A) |
| 35 | 1KS19CS034 | Gulshan Kumar S | 1 | 2 | A | A | A | A | A | A | A | 2 |
| 36 | 1ks19cs066 | Pavithra s p | 1 | A | A | A | A | A | A | A | A | 1 |
| 37 | 1KS19CS086 | Shanvi B P | 1 | 2 | 3 | 4 | 5 | 6 | 7 | 8 | 9 | 9 |
| 38 | 1KS19CS115 | Akshay R | 1 | 2 | 3 | 4 | 5 | A | 6 | 7 | A | 7 |
| 39 | 1KS19CS063 | Nithya s n | 1 | 2 | 3 | 4 | 5 | A | 6 | 7 | 8 | 8 |
| 40 | 1KS19CS073 | Priyanka R | 1 | A | A | A | A | A | 2 | A | A | 2 |
| 41 | 1KS19CS005 | Ajay S Kalburgi | 1 | 2 | A | 3 | A | A | A | A | A | 3 |
| 42 | 1ks19cs084 | Sankalp Kesti | A | A | A | A | A | A | A | A | A | (A) |
| 43 | 1KS19CS098 | Swetha M kulkarni | 1 | 2 | A | A | A | A | A | A | A | 2 |
| 44 | 1KS19CS030 | G PRERITHA | 1 | 2 | A | 3 | 4 | A | 5 | 6 | 7 | 7 |
| 45 | 1KS19CS068 | Pothuru Sai Priyanka | 1 | A | A | 2 | 3 | A | A | A | A | 3 |
| 46 | 1KS19CS033 | Geethanjali BK Prasad | 1 | A | A | A | A | A | A | A | A | 1 |
| 47 | 1KS19CS014 | Anusha B | A | A | A | A | A | A | A | A | A | (A) |
| 48 | 1KS19CS010 | Amogha.HS | 1 | A | A | A | A | A | 2 | A | A | 2 |
| 49 | 1KS19CS113 | Yashwanth S R | 1 | 2 | 3 | 4 | A | A | A | A | A | 4 |
| 50 | 1KS19CS056 | N ASHOK | 1 | 2 | A | 3 | 4 | A | 5 | A | A | 5 |
| 51 | 1KS19CS006 | AKASH A S | A | A | A | A | A | A | A | A | A | (A) |
| 52 | 1KS19CS079 | Ranjitha DV | A | 1 | A | 2 | 3 | 4 | 5 | 6 | 7 | 7 |
| 53 | 1KS19CS092 | Smrithi Shekar | A | A | A | A | A | A | A | A | A | (A) |
| 54 | 1ks19cs090 | Shriharsha | A | A | A | A | A | A | A | A | A | (A) |
| 55 | 1ks19cs016 | Ashika HN | 1 | 2 | 3 | 4 | A | 5 | A | A | A | 5 |
| 56 | 1KS19CS029 | DINESH | 1 | A | A | 2 | 3 | A | A | A | A | 3 |
| 57 | 1KS19CS028 | Dheemanth G | 1 | 2 | A | A | A | A | A | A | A | 2 |
| 58 | 1KS19CS065 | Pavan L | 1 | 2 | A | 3 | A | A | 4 | A | A | 4 |
| 59 | 1KS19CS039 | K.R.VAGEESH | 1 | A | A | A | A | A | A | A | A | 1 |
| 60 | 1KS19CS018 | BHOOMIKA K | 1 | A | A | 2 | 3 | 4 | 5 | 6 | 7 | 7 |
| 61 | 1KS19CS002 | ABHISHEK B | 1 | A | A | 2 | 3 | A | 4 | A | A | 4 |
| 62 | 1KS18CS068 | Prajwal N | A | A | A | A | A | A | A | 1 | A | 1 |
| 63 | 1KS19CS062 | Nikhil Chowdary V R | 1 | 2 | A | 3 | A | A | 4 | A | A | 4 |

73 1KS19CS110 VARSHA R 1 A A 2 3 4 A A A 4

74 1KS19CS050 MAHAKSHREE 1 A A A A A A A A A 1

75 1KS19CS043 KEERTHAN G A A A 1 2 A 3 4 5 5

| | | | | | | | | | | | | |
|--|------------|----------------------|----|----|----|----|----|----|----|----|----|-----|
| 64 | 1KS19CS011 | Amrutha | 1 | 2 | 3 | 4 | 5 | A | 6 | 7 | 8 | 8 |
| 65 | 1KS19CS022 | Chandan BV | 1 | A | A | A | A | A | A | A | A | 1 |
| 66 | 1KS19CS048 | Likith Gopalakrishna | 1 | 2 | A | 3 | 4 | A | 5 | 6 | A | 6 |
| 67 | 1KS20CS403 | Nithin S | 1 | 2 | 3 | A | A | A | A | A | A | 4 |
| 68 | 1KS19CS021 | Chaitanya Shivaraju | 1 | 2 | 3 | 4 | 5 | 6 | 7 | 8 | 9 | 9 |
| 69 | 1KS19CS024 | Deepa G | 1 | 2 | 3 | 4 | 5 | 6 | 7 | 8 | A | 8 |
| 70 | 1KS19CS055 | Mythreyi U | 1 | 2 | 3 | A | A | A | 5 | 6 | 7 | 7 |
| 71 | 1KS19CS067 | Pooja J | A | A | A | A | A | A | A | A | A | (A) |
| 72 | 1KS19CS001 | Aakriti | 1 | 2 | A | A | A | A | A | A | A | 2 |
| No. of students Absent | | | 14 | 34 | 56 | 38 | 41 | 62 | 43 | 47 | 59 | |
| No. of students Present | | | 60 | 40 | 18 | 36 | 34 | 13 | 32 | 28 | 16 | |
| Signature of the trainer/placement coordinator | | | | | | | | | | | | |





K.S INSTITUTE OF TECHNOLOGY, BENGALURU

DEPARTMENT OF TRAINING AND PLACEMENTS

ATTENDANCE FOR NTT DATA COMPANY SPECIFIC TRAINING (BATCH 2) - NB SH 403

| S. No | USN | NAME OF THE STUDENT | VII SEMESTER | | | | | | | | | Total (09) |
|-------|------------|------------------------|--------------|---|---|------------|---|---|------------|---|---|---------------|
| | | | Dates | | | | | | | | | |
| | | | 26/09/2022 | | | 27/09/2022 | | | 28/09/2022 | | | |
| 1 | 2 | 3 | 4 | 5 | 6 | 7 | 8 | 9 | | | | |
| 1 | 1KS19CS057 | N Bhavya | 1 | A | A | A | A | A | A | A | A | 1 |
| 2 | 1KS19CS004 | Adith Karthik Raju | A | A | A | A | A | A | A | A | A | (A) |
| 3 | 1KS19CS042 | KavyaShree S L | A | A | A | 1 | 2 | 3 | A | 4 | 5 | 5 |
| 4 | 1KS19EC074 | Sai Priya TS | 1 | A | A | A | A | A | A | A | A | 1 |
| 5 | 1KS19EC073 | Sahana.S | 1 | 2 | A | 3 | 4 | 5 | 6 | 7 | 8 | 8 |
| 6 | 1KS19EC093 | Sushmitha S | 1 | 2 | A | 3 | 4 | 5 | 6 | 7 | A | 7 |
| 7 | 1KS19EC078 | Shamitha bijoor | 1 | 2 | A | 3 | 4 | 5 | 6 | 7 | A | 7 |
| 8 | 1KS19EC087 | Srinivas S | 1 | 2 | 3 | 4 | 5 | 6 | 7 | 8 | A | 8 |
| 9 | 1KS19EC086 | Sinchana mn | 1 | 2 | A | 3 | 4 | 5 | 6 | 7 | A | 7 |
| 10 | 1KS19EC050 | Monisha B K | 1 | 2 | 3 | 4 | 5 | 6 | 7 | 8 | A | 8 |
| 11 | 1KS19EC018 | Chennreddy Rajasekhar | 1 | 2 | 3 | 4 | 5 | 6 | 7 | A | A | 7 |
| 12 | 1KS19EC104 | Vikas S | A | A | A | 1 | 2 | A | A | A | A | 2 |
| 13 | 1KS19EC069 | Rohan K R | 1 | 2 | A | 3 | A | A | A | A | A | 3 |
| 14 | 1KS19EC022 | Davino Joseph | 1 | 2 | A | 3 | 4 | 5 | 6 | A | A | 6 |
| 15 | 1KS19EC042 | LAKSHMAN KUMARA.B | 1 | 2 | 3 | 4 | 5 | 6 | 7 | A | A | 7 |
| 16 | 1KS19EC001 | Abhilash A S | 1 | 2 | 3 | 4 | 5 | 6 | 7 | A | A | 7 |
| 17 | 1KS19EC035 | Jagruti pai | 1 | A | A | 2 | 3 | 4 | 5 | 6 | 7 | 7 |
| 18 | 1KS19EC096 | T N L RUTHVIK | 1 | 2 | 3 | 4 | 5 | 6 | 7 | 8 | A | 8 |
| 19 | 1KS19EC103 | Vignesh muthaiah R | A | A | A | A | A | A | A | A | A | (A) |
| 20 | 1KS19EC011 | Archana Yadav M | 1 | 2 | 3 | 4 | 5 | 6 | A | 7 | A | 7 |
| 21 | 1KS19EC102 | Vandana S | 1 | 2 | 3 | A | A | A | 4 | 5 | 6 | 6 |
| 22 | 1KS19EC007 | Amruta | 1 | 2 | 3 | 4 | 5 | 6 | 7 | 8 | A | 8 |
| 23 | 1KS19EC041 | Kruthik s | 1 | 2 | A | 3 | 4 | A | 5 | 6 | 7 | 7 |
| 24 | 1KS19EC051 | N.ANILA | 1 | 2 | 3 | 4 | 5 | 6 | 7 | 8 | A | 8 |
| 25 | 1KS19EC004 | Aishwarya M G | 1 | 2 | 3 | 4 | 5 | 6 | 7 | 8 | A | 8 |
| 26 | 1KS19EC020 | D Nayan | 1 | 2 | A | 3 | 4 | A | 5 | 6 | A | 6 |
| 27 | 1KS19EC068 | RANGASWAMY U | A | A | A | A | A | A | 1 | 2 | 3 | 3 |
| 28 | 1KS19EC107 | Vishnuraata Yadunandan | 1 | 2 | A | 3 | 4 | 5 | 6 | 7 | A | 7 |
| 29 | 1KS19EC063 | PREETHAM G H | A | A | A | 1 | 2 | 3 | 4 | A | A | 4 |

| | | | | | | | | | | | | |
|----|------------|------------------------------|---|---|---|---|---|---|---|---|---|---|
| 30 | 1KS19EC084 | Shreyas V Bharadwaj | A | 1 | 2 | 3 | 4 | A | 5 | 6 | A | 6 |
| 31 | 1KS19EC043 | Likitha H | 1 | 2 | A | 3 | 4 | A | A | 5 | A | 5 |
| 32 | 1KS19EC055 | Pavan Kumar G R | 1 | 2 | 3 | 4 | 5 | 6 | 7 | 8 | A | 8 |
| 33 | 1KS19EC070 | S K Bharatesh | 1 | 2 | 3 | 4 | 5 | 6 | 7 | 8 | A | 8 |
| 34 | 1KS19EC028 | Gayathri R Warriar | 1 | 2 | 3 | 4 | 5 | 6 | 7 | 8 | 9 | 9 |
| 35 | 1KS19EC017 | Chandana L | 1 | 2 | 3 | 4 | 5 | 6 | 7 | 8 | A | 8 |
| 36 | 1KS19EC014 | Bhavana S | 1 | 2 | A | 3 | 4 | A | 5 | 6 | A | 6 |
| 37 | 1KS19EC044 | M Lokeshwaria | A | 1 | 2 | 3 | 4 | 5 | 6 | 7 | 8 | 8 |
| 38 | 1KS19EC025 | Disha Shivani | 1 | 2 | 3 | A | A | A | A | A | A | 3 |
| 39 | 1ks19ec049 | Monika V Arya | A | A | A | 1 | 2 | 3 | 4 | 5 | 6 | 6 |
| 40 | 1KS19EC009 | Anitha.S | 1 | 2 | 3 | 4 | 5 | 6 | 7 | 8 | 9 | 9 |
| 41 | 1KS19EC094 | Swagath Aithal PG | 1 | 2 | 3 | A | 4 | A | A | 5 | 6 | 6 |
| 42 | 1KS19EC010 | Anjali Y J | 1 | 2 | 3 | 4 | 5 | A | 6 | 7 | A | 7 |
| 43 | 1KS19EC040 | Krupa A | A | A | A | 1 | 2 | A | 3 | 4 | 5 | 5 |
| 44 | 1KS19EC079 | SHASHANK KASHYAP HR | 1 | 2 | A | 3 | 4 | 5 | 6 | 7 | 8 | 8 |
| 45 | 1KS19EC033 | Hemanth R Patil | 1 | 2 | 3 | 4 | 5 | 6 | 7 | A | A | 7 |
| 46 | 1KS19EC006 | Akshitha | A | 1 | 2 | 3 | 4 | 5 | 6 | 7 | 8 | 8 |
| 47 | 1KS19EC106 | Vishal Sanjay Raju | 1 | 2 | A | 3 | 4 | A | 5 | 6 | A | 6 |
| 48 | 1KS19EC021 | Danesh Raju v | 1 | 2 | 3 | 4 | 5 | 6 | 7 | A | 8 | 8 |
| 49 | 1KS19EC008 | Amulya R | 1 | 2 | 3 | 4 | 5 | A | 6 | 7 | 8 | 8 |
| 50 | 1KS19EC046 | Meghana H P | 1 | 2 | 3 | 4 | 5 | 6 | 7 | 8 | A | 8 |
| 51 | 1KS19EC064 | Priyanka K | 1 | 2 | 3 | 4 | 5 | 6 | 7 | 8 | A | 8 |
| 52 | 1KS19EC039 | Kashyap P | 1 | 2 | A | A | A | A | 3 | 4 | A | 4 |
| 53 | 1KS19EC061 | Prashanth SK | A | 1 | 2 | 3 | 4 | 5 | 6 | 7 | A | 7 |
| 54 | 1KS19EC030 | Gowri S N | 1 | 2 | 3 | 4 | 5 | 6 | A | 7 | 8 | 8 |
| 55 | 1KS19EC053 | Nisargak | A | A | A | 1 | 2 | 3 | 4 | 5 | 6 | 6 |
| 56 | 1KS19EC037 | Manogna K M | A | 1 | 2 | 3 | 4 | 5 | 6 | 7 | 8 | 8 |
| 57 | 1KS19EC045 | Manu N Kandra | A | 1 | 2 | 3 | 4 | 5 | 6 | 7 | 8 | 8 |
| 58 | 1KS19EC024 | DHEEMANTH KN | 1 | 2 | 3 | 4 | 5 | 6 | 7 | A | 8 | 8 |
| 59 | 1KS19EC032 | B.Y.Harshitha | 1 | 2 | 3 | A | A | A | A | 5 | A | 5 |
| 60 | 1KS19EC003 | Aishwarya Basavaraja Kembavi | 1 | 2 | 3 | 4 | 5 | 6 | 7 | 8 | 9 | 9 |
| 61 | 1KS19EC092 | SUMUKHA VASISHTA M R | 1 | 2 | A | 3 | 4 | 5 | 6 | 7 | 8 | 8 |
| 62 | 1KS19EC056 | Pokuri Mounika | 1 | A | A | 2 | 3 | A | A | A | A | 3 |
| 63 | 1KS19EC101 | Vandana.G | 1 | 2 | 3 | 4 | 5 | 6 | 7 | 8 | 9 | 9 |
| 64 | 1KS19EC005 | Akshay kumar d | 1 | 2 | 3 | 4 | 5 | 6 | 7 | 8 | 9 | 9 |
| 65 | 1KS19EC016 | Chandan Raj Y | 1 | 2 | 3 | 4 | 5 | A | 6 | 7 | 8 | 8 |

72 1KS19EC059 SRI RAM

A 1 A 2 3 4 5 6 A 6

| | | | | | | | | | | | | |
|--|------------|-----------------------|----|----|----|----|----|----|----|----|----|-----|
| 66 | 1KS19EC085 | Shubham Kumar Singh A | 1 | 2 | A | 3 | 4 | 5 | 6 | 7 | 8 | 8 |
| 67 | 1KS19EC076 | Santosh Hegde | 1 | 2 | 3 | 4 | 5 | 6 | 7 | 8 | 9 | 9 |
| 68 | 1ks19ec098 | Theerthana S R | 1 | 2 | A | 3 | 4 | 5 | 6 | 7 | A | 7 |
| 69 | 1KS19EC082 | Shreyas B Aradhya | A | A | A | A | A | A | A | A | A | (A) |
| 70 | 1KS19EC015 | Chaitra p | 1 | 2 | A | 3 | 4 | A | 5 | 6 | 7 | 7 |
| 71 | 1KS19EC027 | Gayathri P K | 1 | A | A | A | A | A | A | A | A | 1 |
| No. of students Absent | | | 16 | 16 | 34 | 12 | 12 | 26 | 15 | 18 | 44 | |
| No. of students Present | | | 55 | 56 | 38 | 60 | 60 | 46 | 57 | 54 | 28 | |
| Signature of the trainer/placement coordinator | | | P | P | P | P | P | P | P | P | P | P |



Departments of Training and Placements

NTT DATA Company Specific Training Program_2022-2023

Date: 26th – 28th September 2022

Semester: 7th Semester (CSE & ECE)

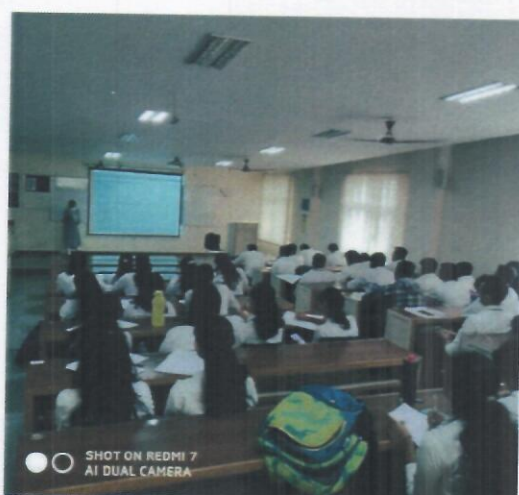

Batch 1: CSE – Session 2 (Day 3)



Batch 2: ECE – Session 3 (Day 3)



Batch 1: CSE – Session 3 (Day 2)

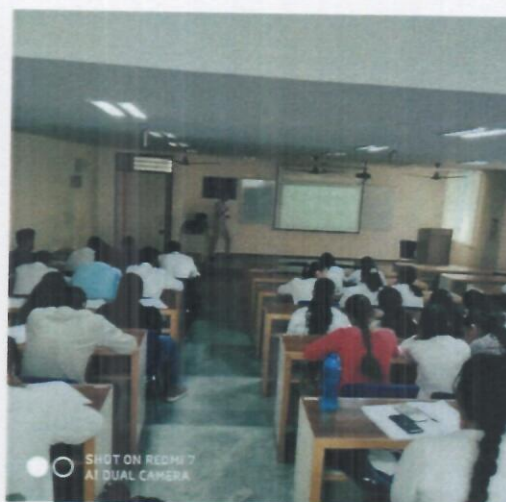

Batch 2: ECE – Session 1 (Day 1)

K.S. INSTITUTE OF TECHNOLOGY

**DEPARTMENT OF MECHANICAL ENGINEERING
SKILL DEVELOPMENT REPORT - 2022**

As part of skill development program, 3rd semester students were given training in solid modeling, finite element analysis and Ansys in a 5 day program. The program schedule is as follows.

Internship program for 3rd Semester

5 days program for 3rd semester mechanical students(17/10/22 – 21/10/22) :

| Date | Program Description | Time | Staff |
|------------|--|-----------------|-----------------|
| 17/10/2022 | Introduction to Autocad and practice | 9 am – 12.30 pm | Harish U |
| | Practice on block, layer commands | 1.15 pm – 4 pm | Harish U |
| 18/10/2022 | Practice on Autocad drafting exercises | 9 am – 12.30 pm | Harish U |
| | Tolerance representation | 1.15 pm – 4 pm | Harish U |
| 19/10/2022 | Introduction to Matlab and Matlab programming | 9 am – 12.30 pm | M. Nagabhushana |
| | Programming aspects of Matlab | 1.15 pm – 4 pm | M. Nagabhushana |
| 20/10/2022 | Matlab programming | 9 am – 12.30 pm | M. Nagabhushana |
| | Function writing | 1.15 pm – 4 pm | M. Nagabhushana |
| 21/10/2022 | Introduction to Ansys workbench and practice on engineering problems | 9 am – 12.30 pm | M. Nagabhushana |
| | Report generation using workbench | 1.15 pm – 4 pm | M. Nagabhushana |

Thanks
11/10/22
Head of the Department
Dept. of Mechanical Engg.
K.S. Institute of Technology
Bengaluru - 560 109.

Shravan G
11/10/22

Schedule for Training

Before starting with the training, need of CAD and CAE technologies were discussed and the discussed matter is as follows.

About Training:

Technology has advanced at an ever increasing, almost exponential rate. In fact, technology development moves faster than the consumers understanding of the resulting product enhancements. When an activity of the product development cycle is carried out in a virtual or soft environment, the primary benefit is the time saving and hence cost saving

Computer Aided Engineering is a technology concerned with the use of computer systems to analyze CAD geometry, allowing the designer to simulate and study how the product will behave so that design can be refined and optimized.

History of FEA:

Finite Element Analysis (FEA) was first developed in 1943 by R. Courant, who utilized the Ritz method of numerical analysis and minimization of variational calculus to obtain approximate solutions to vibration systems. Shortly thereafter, a paper published in 1956 by Turner, Clough, Martin, & Top established a broader definition of numerical analysis. This paper centered on the "stiffness and deflection of complex structures".

By the early 70's, FEA was limited to expensive mainframe computers generally owned by the aeronautics, automotive, defense, and nuclear industries, and the scope of analyses were considerably limited. Such people as Zeinkiewich & Cheung further enhanced finite Element technology during the 70's, when they applied the technology to general problems described by Laplace & Poisson's equations. Mathematicians were developing better solution algorithms, the Galerkin, Ritz & Rayleigh-Ritz methods emerged as the optimum solutions for certain categories of general type problems. Later, considerable research was carried out into the modeling & solution of non-linear problems, Hinton & Crisfield being major contributors. While considerable strides were made in the development of the finite element method, other areas did not remain static. Very powerful mesh generation algorithms have been developed. Commercial generators have the capability of meshing all but the most difficult geometry. Superior CAE concepts have also emerged; it is not unusual to have a single CAD model for producing engineering drawings, carrying out kinematics & assembly analysis, as well as being used

for finite element modeling. Due to the rapid decline in the cost of computers and the phenomenal increase in computing power, present day desktop computers are capable of producing accurate results for all kinds of parameters (standard PC's are over 10 times more powerful than the best supercomputers of the early 90's)

The finite element method now has its roots in many disciplines, the end result is a technology that is so advanced that it is almost indistinguishable from magic. The vast catalog of capability that comprises FEA will no doubt grow considerably larger in the future. CAE is here to stay, but in order to harness its true power, the user must be familiar with many concepts, including the mechanics of the problem being modeled. All analyses require time, experience & most importantly, careful planning.

The finite element method is being used in virtually every engineering discipline. Aerospace, automotive, biomedical, geotechnical, electrical, hydraulic, and nuclear engineering applications have become standard objects for finite element analysis. In addition, it is not only used for analyzing classical static structural problems, but also for such diverse areas as mass transport, heat transfer, dynamics, stability, and radiation problems. Like any other approximate numerical method, the solution produced by finite element analysis contains a certain amount of error. The magnitude of the error is highly dependent on the type, size, and fineness of the model used for the analysis. That's why not all finite element models are created equal. Indeed, the educational and industrial experiences of the analyst as well as the sophistication of the software are the most critical factors in obtaining reliable results.

Finite Element Analysis:

Is the simulation of a physical system (geometry and loading environment) by a mathematical approximation of the real system. Using simple, interrelated building blocks called elements; a real system with infinite unknowns is approximated with a finite number of unknowns. A FEA Model is the mathematical idealization of the real system.

A Typical Analysis Procedure:

In the real world, no analysis is typical, as there are usually facets that cause it to differ from others. There is however a main procedure that most FE investigations take. This procedure is detailed below:

Planning the Analysis:

This is arguably the most important part of any analysis, as it helps ensure the success of the simulation. Oddly enough, it is usually the one analysts leave out. The purpose of an FE analysis is to model the behavior of a structure under a system of loads. In order to do so, all influencing factors must be considered & determined whether their effects are considerable or negligible on the final result. The degree of accuracy to which any system can be modeled is very much dependant on the level of planning that has been carried out.

Pre-Processor

The preprocessor stage in general FE packages involves the following:

1. Specifying the title that is the name of the problem. This is optional but very useful,
2. Setting the type of analysis to be used, e.g. structural, fluid, thermal or electromagnetic, etc. (sometimes this can only be done by selecting a particular element type). Especially if a number of design iterations are to be completed on the same base model.
3. Creating the model. The model is drawn in 1D, 2D or 3D space in the appropriate units (M, mm, in, etc.). The model may be created in the pre-processor, or it can be imported from another CAD drafting package via a neutral file format (IGES, STEP, ACIS, Parasolid, DXF, etc.). If a model is drawn in mm for example and the material properties are defined in SI units, then the results will be out of scale by factors of 10^6 . The same units should be applied in all directions, otherwise results will be difficult to interpret, or in extreme cases the results will not show up mistakes made during the loading and restraining of the model.

4. Defining the element type, this may be 1D, 2D or 3D, and specific to the analysis type being carried out (you need thermal elements to do thermal analyses).

5. Applying a Mesh. Mesh generation is the process of dividing the analysis continuum into a number of discrete parts or finite elements. The finer the mesh, the better the result, but the longer the analysis time. Therefore, a compromise between accuracy & solution speed is usually made.

6. Assigning properties. Material properties (Young's modulus, Poisson's ratio, the density, & if applicable, coefficients of expansion, friction, thermal conductivity, damping effect, specific heat etc.) will have to be defined. In addition element properties may need to be set. If 2D elements are being used, the thickness property is required. 1D beam elements require area, I_{xx} , I_{yy} , I_{xy} , J , & a direction cosine property, which defines the direction of the beam axis in 3D space. Shell elements, which are 2½D in nature (2D elements in 3D space), require orientation & neutral surface offset parameters to be defined. Special elements (mass, contact, spring, gap, coupling, damper etc.) require properties (specific to the element type) to be defined for their use.

7. Apply Loads. Some type of load is usually applied to the analysis model. The loading may be in the form of a point load, a pressure or a displacement in a stress (displacement) analysis, a temperature or a heat flux in a thermal analysis & a fluid pressure or velocity in a fluid analysis. The loads may be applied to a point, an edge, a surface or a even a complete body. The loads should be in the same units as the model geometry & material properties specified. In the cases of modal (vibration) & buckling analyses, a load does not have to be specified for the analysis to run.

8. Applying Boundary Conditions. If you apply a load to the model, then in order to stop it accelerating infinitely through the computer's virtual ether (mathematically known as a zero pivot), at least one constraint or boundary condition must be applied. Structural boundary conditions are usually in the form of zero displacements, thermal BCs are usually specified temperatures, fluid BCs are usually specified pressures. A boundary condition may be specified to act in all directions (x, y, z), or in certain directions only. They can be placed on nodes, key points, areas or on lines. BC's on lines can be in the form of symmetric or anti-symmetric type boundary conditions, one allowing in plane rotations and out of plane translations, the other allowing in plane translations and out of

plane rotations for a given line. The applications of correct boundary conditions are a critical to the accurate solution of the design problem. At least one BC has to be applied to every model, even modal & buckling analyses with no loads applied.

Solution

Thankfully, this part is fully automatic. The FE solver can be logically divided into three main parts, the pre-solver, the mathematical-engine & the post-solver. The pre-solver reads in the model created by the pre-processor and formulates the mathematical representation of the model. All parameters defined in the pre-processing stage are used to do this, so if you left something out, chances are the pre-solver will complain & cancel the call to the mathematical-engine. If the model is correct the solver proceeds to form the element-stiffness matrix for the problem & calls the mathematical-engine, which calculates the result (displacement, temperatures, pressures, etc.). The results are returned to the solver & the post-solver is used to calculate strains, stresses, heat fluxes, velocities, etc.) for each node within the component or continuum. All these results are sent to a results file, which may be read by the post-processor.

Post-Processor

Here the results of the analysis are read & interpreted. They can be presented in the form of a table, a contour plot, deformed shape of the component or the mode shapes and natural frequencies if frequency analysis is involved. Other results are available for fluids, thermal and electrical analysis types. Most post-processors provide an animation service, which produces an animation & brings your model to life.

Contour plots are usually the most effective way of viewing results for structural type problems. Slices can be made through 3D models to facilitate the viewing of internal stress patterns.

All post-processors now include the calculation of stress & strains in any of the x, y or z directions, or indeed in a direction at an angle to the coordinate axes. The principal stresses and strains may also be plotted, or if required the yield stresses and strains according to the main theories of failure (Von mises, St. Venant, Tresca etc.). Other

information such as the strain energy, plastic strain and creep strain may be obtained for certain types of analyses.

A Final Word The finite element method is extremely powerful. However, with comforting contour plots, one can be easily fooled into thinking that a superior result has been achieved. The quality of the result is totally dependent on the quality of the analysis model & how accurately it represents the physical problem being investigated. Careful planning is the key to a successful analysis. Sometimes an analysis is not required, as some problems have analytical or empirical solutions; others may be determined using spreadsheets.

General finite element process is illustrated as below:

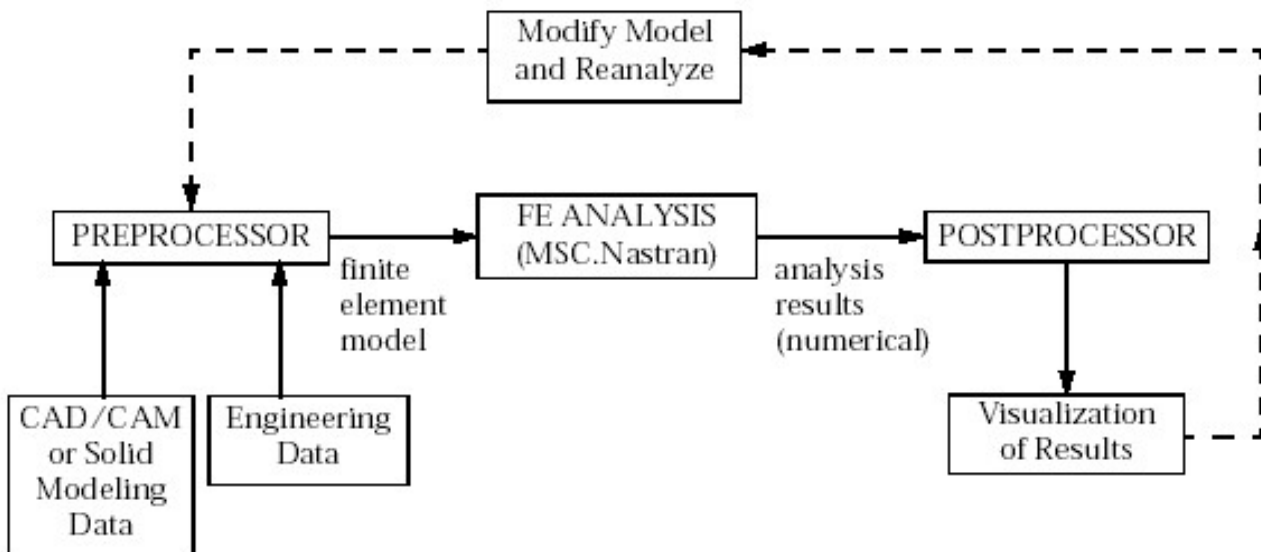

IMPORTING AND EXPORTING DATA

The cad models in step and sat file format creation is important for importing into analysis softwares for further analysis.

As part of training , the following problems were given training to the students.

CASE STUDY 1: RECTANGULAR PLATE WITH ELLIPTICAL HOLE

Objectives:

- Manually create the geometry using the given dimensions then apply finite elements.
- Manually define material and element properties.
- Apply symmetric boundary constraints.
- Apply edge load to model.
- Run the analysis in ansys

MODEL DISCRIPTION:

Below is a schematic of a plate with a elliptical hole at the center. The dimensions and loads are indicated. The finite element model will be simplified by creating the 1/4 tension model with two simple surfaces as shown in Fig. The plate is 10mm thick; therefore it will be modeled with shell elements. The resulting finite element model will have x- and y-symmetry constraints. The uniform load of 30 kg will be applied to the right edge.

All dimensions are in mm

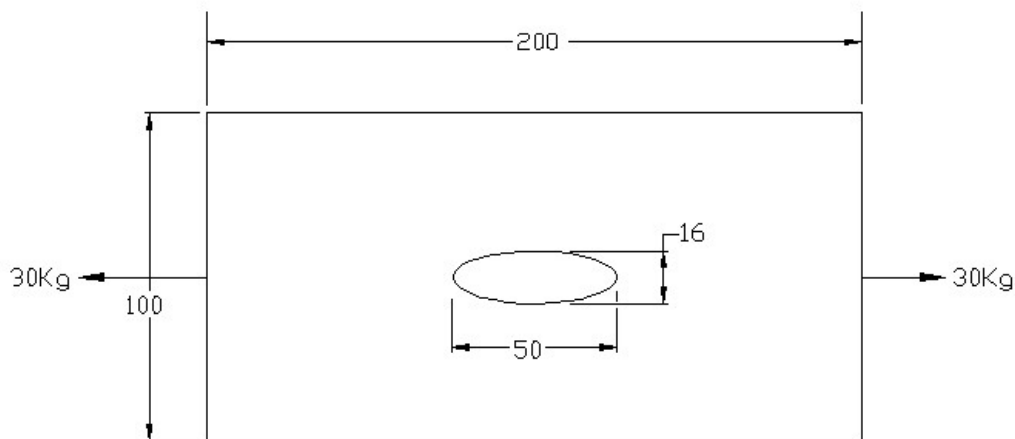

Fig: Geometry details

Skill Development Report

Material=Aluminium

Thickness: $t = 10\text{mm}$

Applied Load: $F = 30\text{mm}$

Youngs

modulus= 7100kg/mm^2

Poisson Ratio = 0.33

Thickness= 10.0mm

$$\begin{aligned}\sigma_{\max} &= K \sigma_{\text{nom}} \\ &= 1.64 * 0.047 = 0.077\text{kg/mm}\end{aligned}$$

$$\begin{aligned}\text{Nominal stress } (\sigma_{\text{nom}}) &= F/A \\ &= 30/628.4 = 0.047 \text{ kg/mm}^2\end{aligned}$$

Stress Concentration Factor (K) = $1 + 2(a/b)$

For Elliptical $a = 25\text{mm}, b = 8\text{mm}$

$$K = 1 + 2(8/25)$$

$$K = 1.64$$

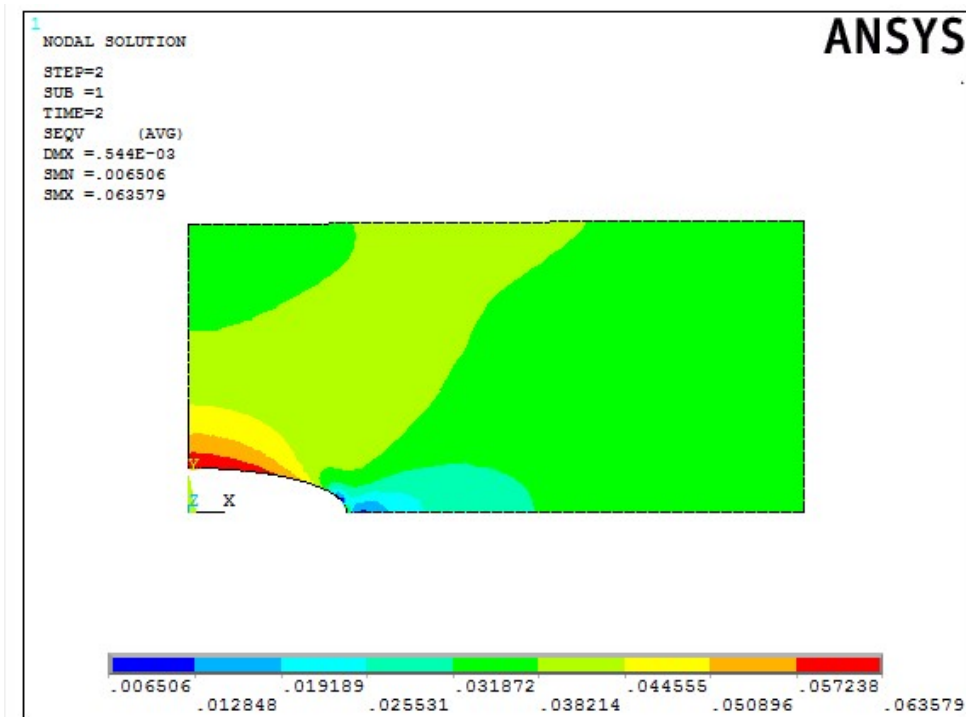

Fig: Vonmises stress plot

From ansys :

$$K=0.0635/0.047=1.35$$

Biaxial Loading:

$$\text{Maximum stress } (\sigma_{\max}) = 2.66 \text{ kg/mm}^2$$

$$\text{Nominal stress } (\sigma_{\text{nom}}) = 1.381 \text{ kg/mm}^2$$

$$\text{Stress Concentration Factor (K)} = \sigma_{\max} / \sigma_{\text{nom}} \\ = 2.66 / 1.381$$

$$K=1.92$$

CASE STUDY 2: FRAME OF A PUNCH PRESS.

Objective:

To find the stresses at the inner and outer surface at section of a punch press with load $W=5000\text{N}$

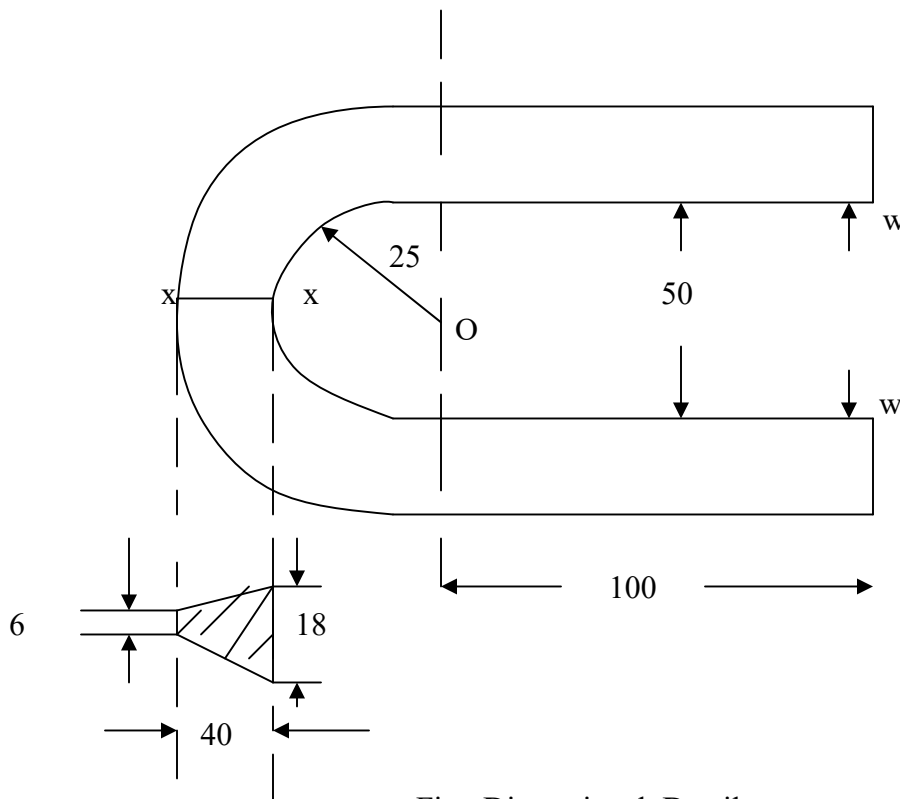

Fig: Dimensional Details

Given: $W=5000\text{N}$, $b_i = 18\text{mm}$, $b_o = 6\text{mm}$, $h=40\text{mm}$, $R_i = 25\text{mm}$, $R_o = 25+40=65\text{mm}$.

Wkt area of section X-X,

$$A = \frac{1}{2}(18+6) \times 40 = 480\text{mm}^2$$

Radius of curvature of the neutral axis ,

$$R_n = \frac{(b_i + b_0/2)h}{(b_i R_o - b_0 R_i / h) \log(R_o / R_i)(b_i - b_0)}$$

$$R_n = \frac{(18+6/2) \times 40}{(18 \times 65 - 6 \times 25 / 40) \log(65 / 25)(18 - 6)}$$

$$R_n = 38.83\text{mm}.$$

Radius of curvature of the centroidal axis,

$$R = R_i + \frac{h(b_i + 2b_0)}{3(b_i + b_0)} = 25 + \frac{40(18 + 2 \times 6)}{3(18 + 6)}$$

$$R = 41.67\text{mm}.$$

Distance between the centroidal and neutral axis,

$$E = R - R_n = 41.67 - 38.83 = 2.84\text{mm}$$

And the distance between the load and centroidal axis,

$$X = 100 + R = 100 + 41.67 = 141.67\text{mm}.$$

Therefore bending moment about the centroidal axis ,

$$M = W \cdot X = 5000 \times 141.67 = 708350 \text{ N-mm}.$$

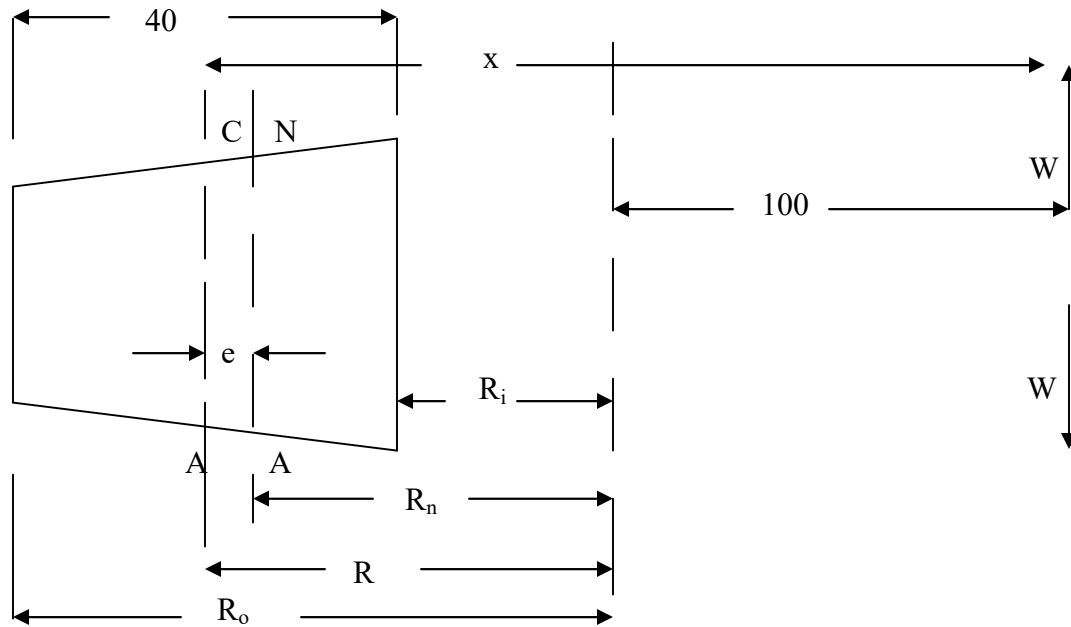

Fig: Sectional details

The direct tensile stress at section X-X.

$$\sigma_t = W/A = 5000/480 = 10.42 \text{ N/mm}^2$$

Distance from the neutral axis to the inner surface,

$$y_i = R_n - R_i = 38.83 - 25 = 13.83 \text{ mm}$$

Distance from the neutral axis to the outer surface,

$$y_o = R_o - R_n = 65 - 38.83 = 26.17 \text{ mm.}$$

Wkt maximum bending stress at the inner surface,

$$\begin{aligned} \sigma_{bi} &= \frac{M \cdot y_i}{A \cdot e \cdot R_i} = \frac{708350 \cdot 13.83}{480 \cdot 2.84 \cdot 25} = 287.4 \text{ N/mm}^2 \\ &= 287.4 \text{ Mpa (tensile)} \end{aligned}$$

Maximum bending stress at the outer surface,

$$\sigma_{bo} = \frac{M \cdot y_o}{A \cdot e \cdot R_o} = \frac{708350 \cdot 26.17}{480 \cdot 2.84 \cdot 65} = 209.2 \text{ N/mm}^2$$

$$= 209.2 \text{ Mpa (compressive)}$$

Therefore resultant stress on the inner surface

$$= \sigma_t + \sigma_{bi} = 10.42 + 287.4 = 297.82 \text{ Mpa (tensile)}$$

Resultant stress on the outer surface,

$$= \sigma_t - \sigma_{bo} = 10.42 - 209.2 = -198.78 \text{ Mpa (compressive)}$$

FROM FEA METHOD:

FE Model of a punch press.

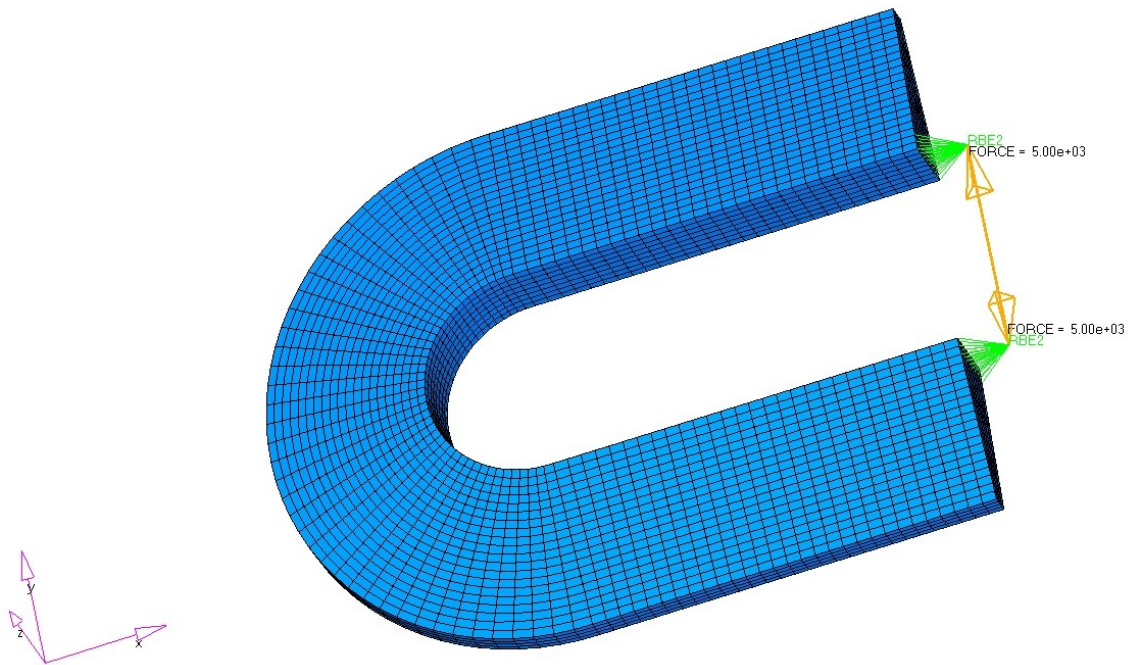
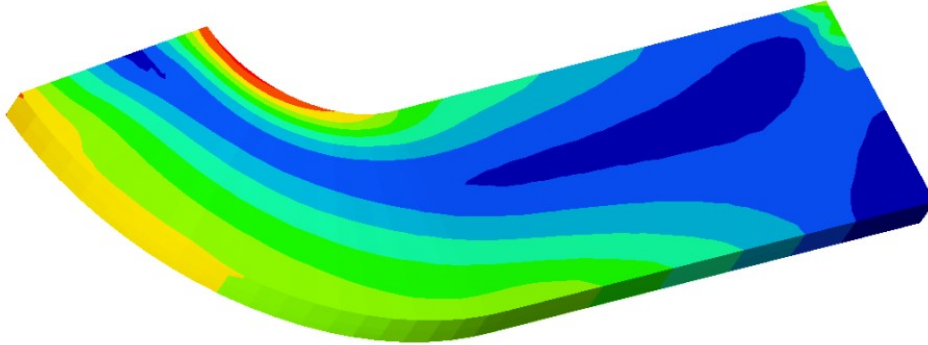

Fig: Mesh model

Due to half symmetry, half model with symmetrical boundary conditions were analysed.



Results from FEA

Stress – Von Mises

Resultant stress on the inner surface,

= 286.4 Mpa (tensile).

Resultant stress on the outer surface,

= 191.0 Mpa (compressive)

CASE 3 : L-Frame Stress analysis subjected to 1000N Cabin load

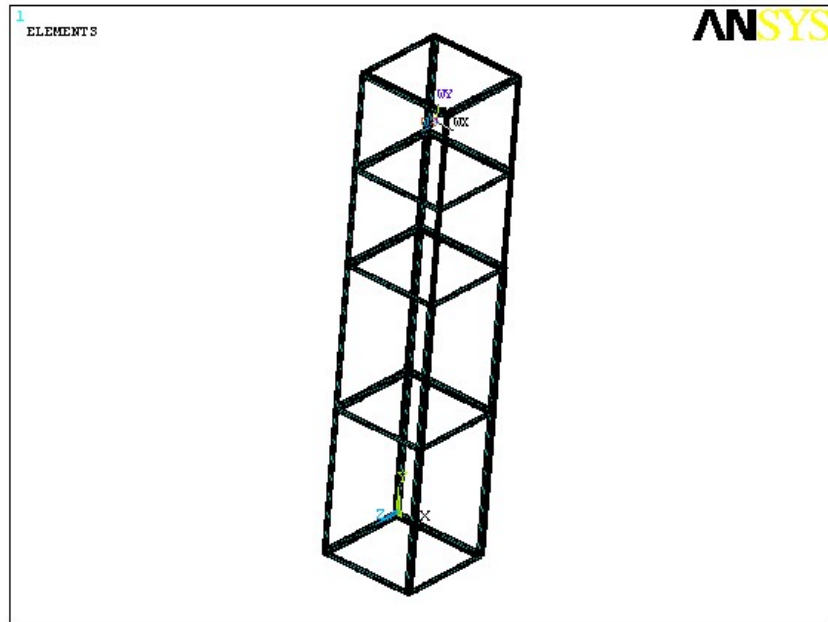

Fig: L Frame Element Plot

The above picture shows element representation of the problem.

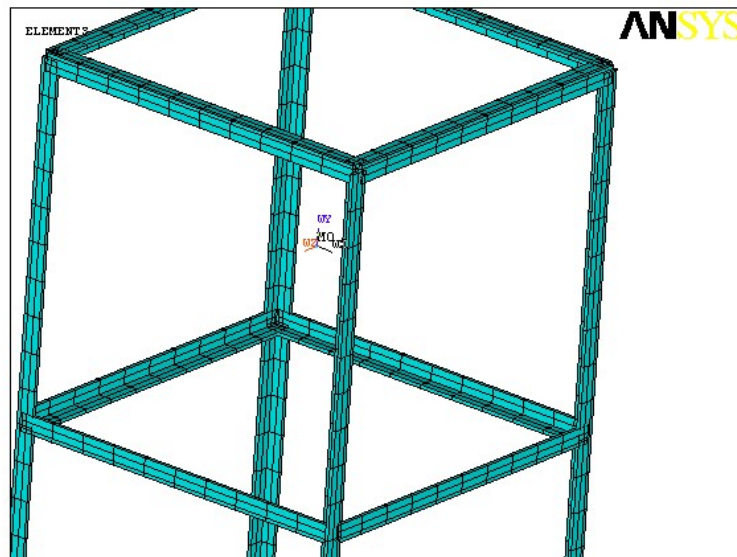

Fig : Zoomed view of Frame

The above picture shows zoomed view of the problem. L sections are used for creating the model

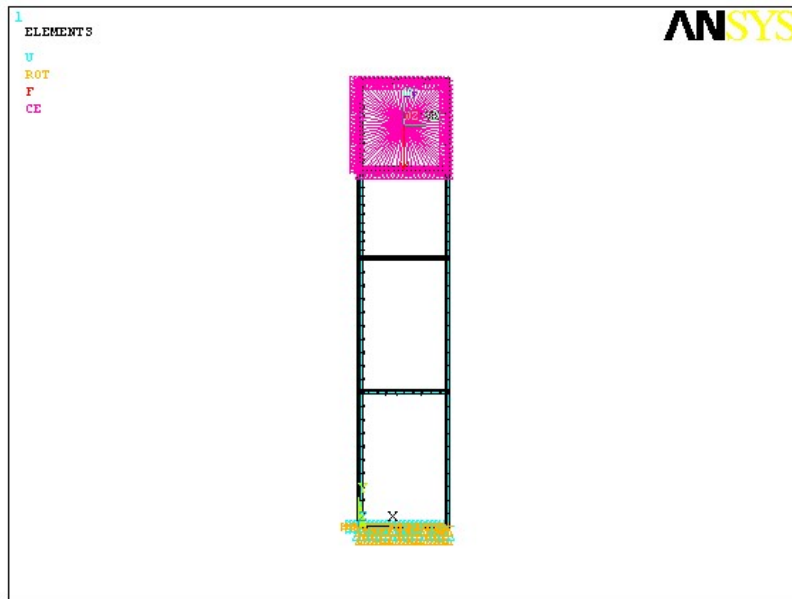

Fig : Boundary Conditions of the problem

The above picture shows applied boundary conditions of the problem. RBE elements are used to apply the cabin weight load of 1000N. The RBE linking is shown with red color.

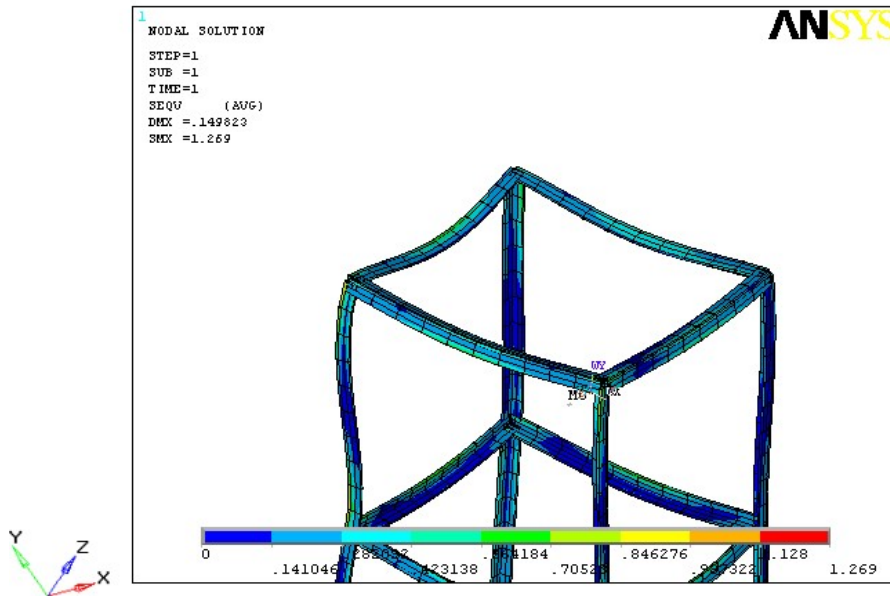

Fig : Vonmises Stress in the problem

The above picture shows vonmises stress in the problem. Maximum vonmises is around 1.269 Mpa due to the loading. The variation of stresses are represented in the status bar.

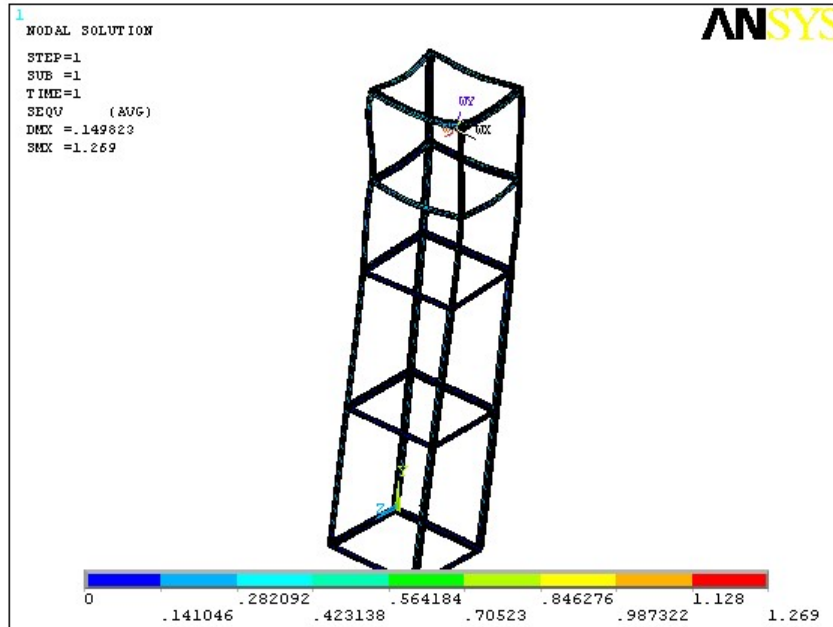

Fig : Vonmises Stress in the problem

The vonmises stress distribution is shown in the picture. Maximum vonmises stress is around 1.269 Mpa for the given loads.

Autocad Training :

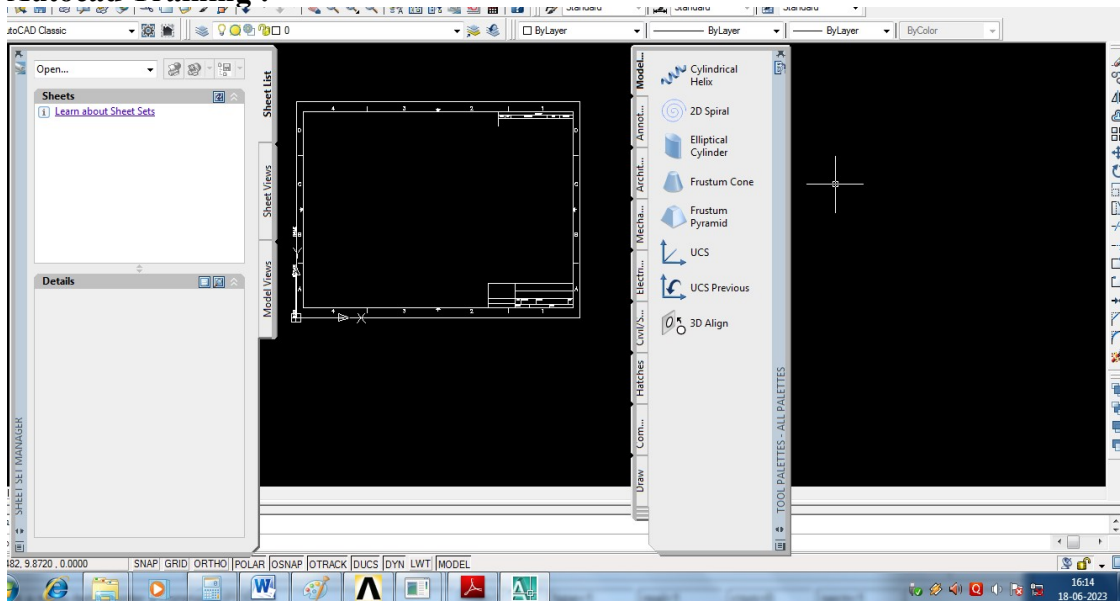

Fig: New sheet representation

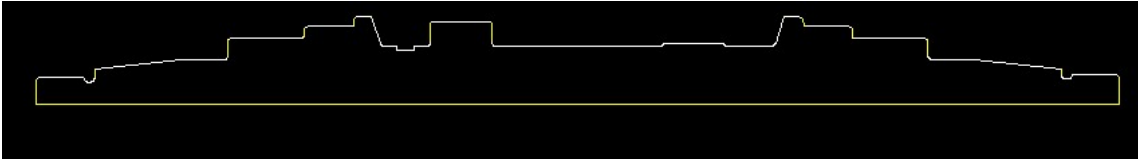

Fig: Drawing a profile section for axisymmetry problem

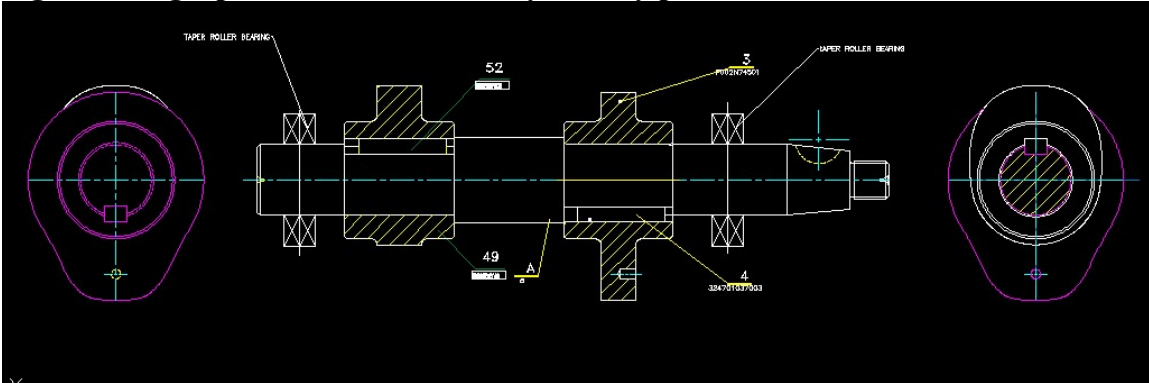

Fig: Dimensional representation of cam shaft assembly





Fig: Students undergoing training

Conclusion

The students undergone training in autocad and ansys and applied various ansys modeling techniques for geometrical built up and analysis along with possible theoretical validation. In autocad they practiced basic autocad commands and generated few drawings in two dimensional space.

PRINCIPAL
K.S INSTITUTE OF TECHNOLOGY
BENGALURU - 560 109